

Sheet-Forming Processes

Chapter 17

17.1 Introduction

- Sheet metal processes involve plane stress loadings and lower forces than bulk forming
- Almost all sheet metal forming is considered to be secondary processing
- The main categories of sheet metal forming are:
 - Shearing
 - Bending
 - Drawing

17.2 Shearing Operations

- Shearing- mechanical cutting of material without the formation of chips or the use of burning or melting
 - Both cutting blades are straight
- Curved blades may be used to produce different shapes
 - Blanking
 - Piercing
 - Notching
 - Trimming

Metalforming

TABLE 17-1 Classification of the Nonsqueezing Metalforming Operations

Shearing	Bending	Drawing and Stretching
1. Simple shearing	1. Angle bending	1. Spinning
2. Slitting	2. Roll bending	2. Shear forming or flow turning
3. Piercing	3. Draw bending	3. Stretch forming
4. Blanking	4. Compression bending	4. Deep drawing and shallow drawing
5. Fineblanking	5. Press bending	5. Rubber-tool forming
6. Lancing	6. Tube bending	6. Sheet hydroforming
7. Notching	7. Roll forming	7. Tube hydroforming
8. Nibbling	8. Seaming	8. Hot drawing
9. Shaving	9. Flanging	9. High-energy-rate forming
10. Trimming	10. Straightening	10. Ironing
11. Cutoff		11. Embossing
12. Dinking		12. Superplastic sheet forming

Shearing Operations

- Fracture and tearing begin at the weakest point and proceed progressively or intermittently to the next-weakest location
 - Results in a rough and ragged edge
- Punch and die must have proper alignment and clearance
- Sheared edges can be produced that require no further finishing

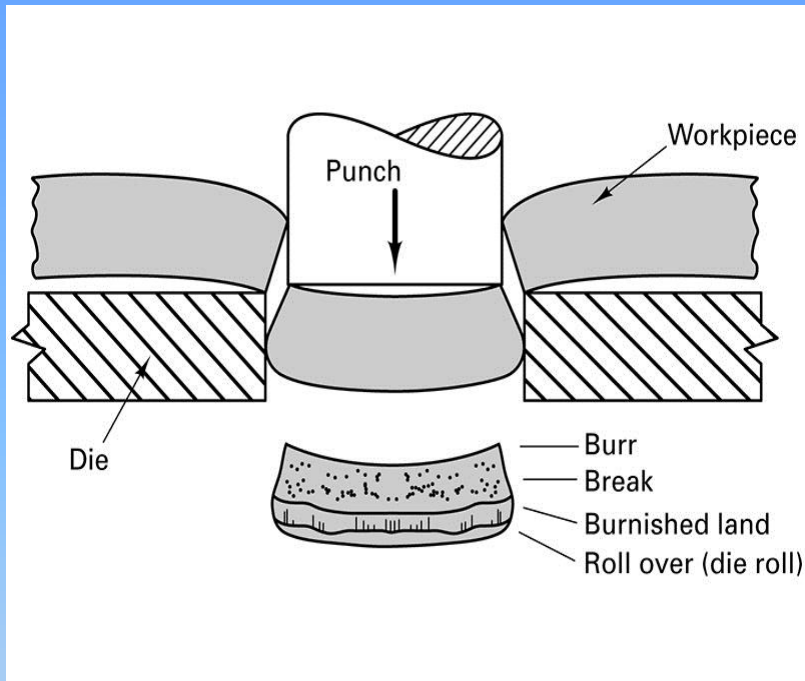

Figure 17-1 (Left) Simple blanking with a punch and die.

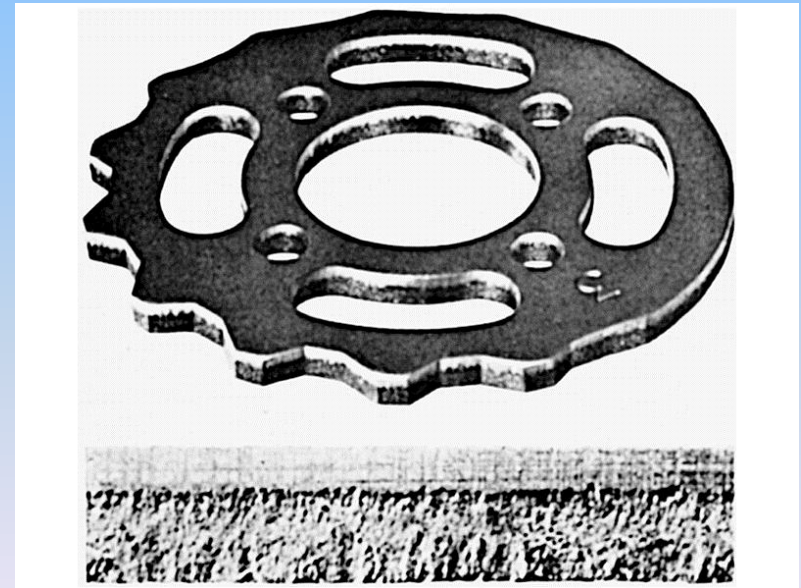

Figure 17-2 (Right) (Top) Conventionally sheared surface showing the distinct regions of deformation and fracture and (bottom) magnified view of the sheared edge. (Courtesy of Feintool Equipment Corp., Cincinnati, OH.)

Figure 17-3 (Right) Method of obtaining a smooth edge in shearing by using a shaped pressure plate to put the metal into localized compression and a punch and opposing punch descending in unison.

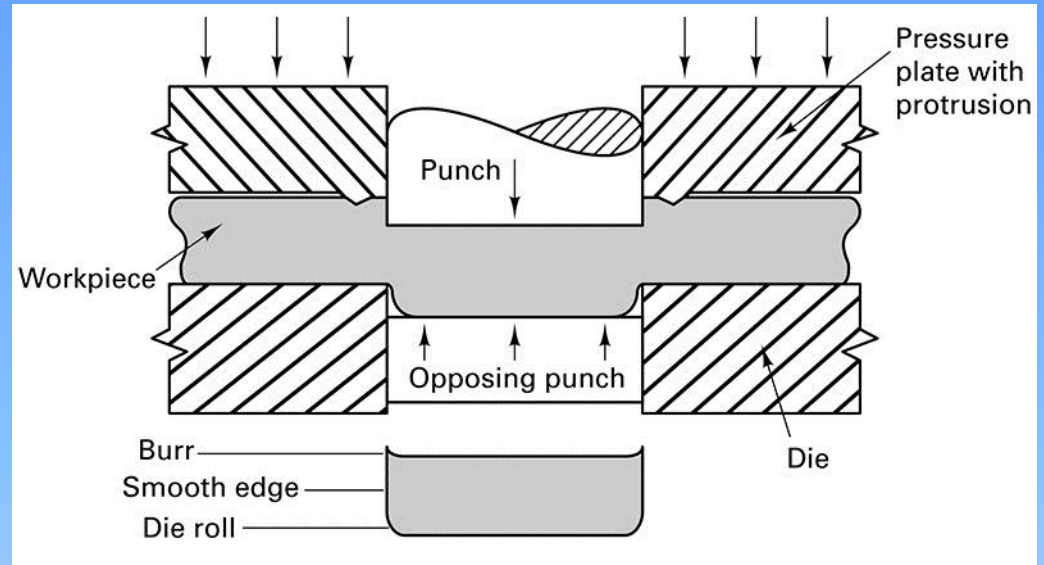

Figure 17-4 Fineblanked surface of the same component as shown in Figure 17-2. (Courtesy of Feintool Equipment Corp., Cincinnati, OH.)

Types of Shearing

- Simple shearing- sheets of metal are sheared along a straight line
- Slitting- lengthwise shearing process that is used to cut coils of sheet metal into several rolls of narrower width

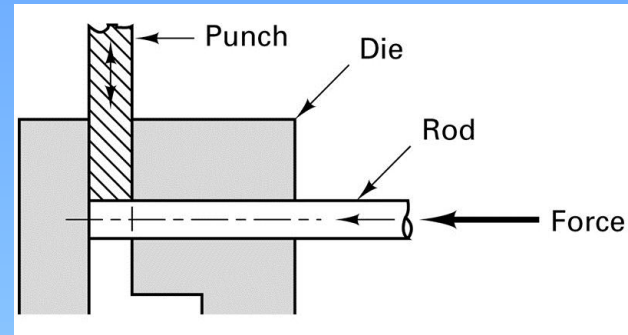

Figure 17-5 Method of smooth shearing a rod by putting it into compression during shearing.

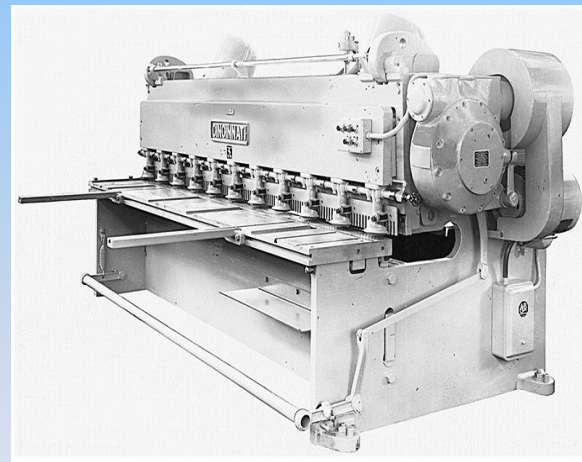

Figure 17-6 A 3-m (10ft) power shear for 6.5 mm (1/4-in.) steel. (Courtesy of Cincinnati Incorporated, Cincinnati, OH.)

Piercing and Blanking

- Piercing and blanking are shearing operations where a part is removed from sheet material by forcing a shaped punch through the sheet and into a shaped die
- Blanking- the piece being punched out becomes the workpiece
- Piercing- the punchout is the scrap and the remaining strip is the workpiece

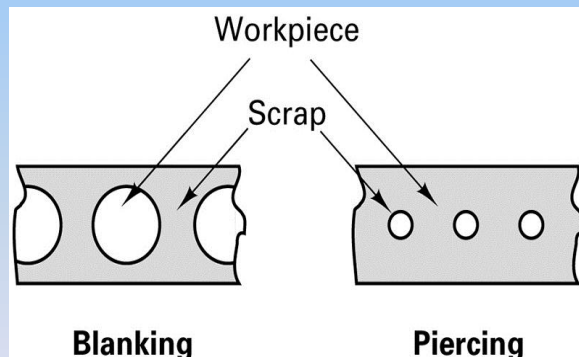

Figure 17-7 Schematic showing the difference between piercing and blanking.

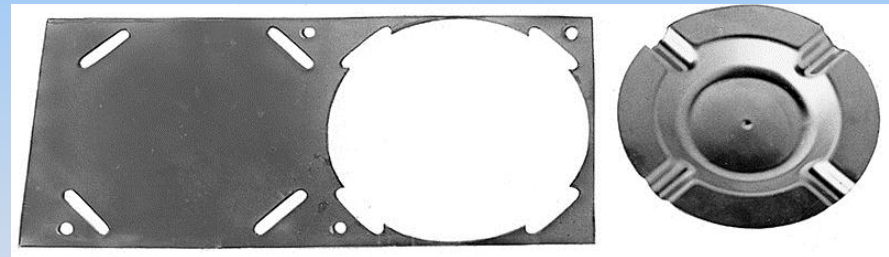

Figure 17-8 (Above) (Left to Right) Piercing, lancing, and blanking precede the forming of the final ashtray. The small round holes assist positioning and alignment.

Types of Piercing and Blanking

- Lancing- piercing operation that forms either a line cut or hole
- Perforating- piercing a large number of closely spaced holes
- Notching- removes segments from along the edge of an existing product
- Nibbling- a contour is progressively cut by producing a series of overlapping slits or notches

Types of Piercing and Blanking

- Shaving- finishing operation in which a small amount of metal is sheared away from the edge of an already blanked part
- Cutoff- a punch and a die are used to separate a stamping or other product from a strip of stock
- Dinking- used to blank shapes from low-strength materials such as rubber, fiber, or cloth

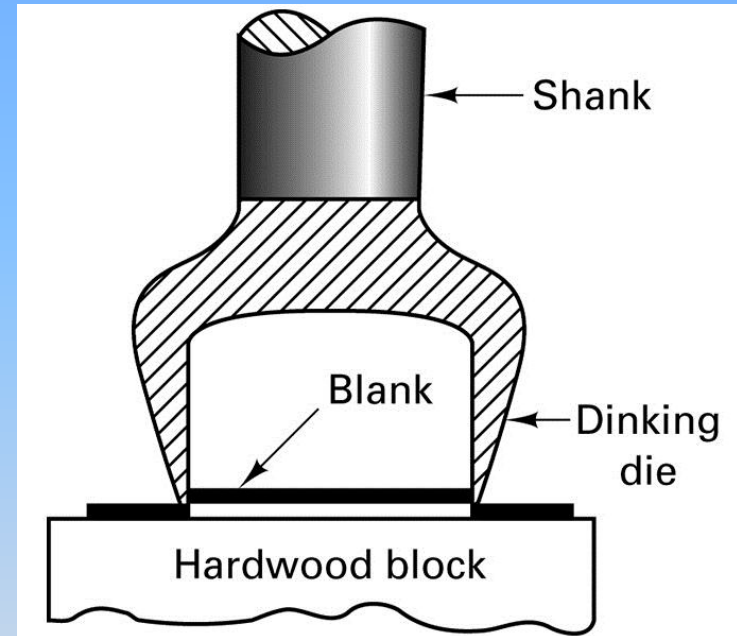

Figure 17-10 The dinking process.

Tools and Dies for Piercing and Blanking

- Basic components of a piercing and blanking die set are: punch, die, and stripper plate
- Punches and dies should be properly aligned so that a uniform clearance is maintained around the entire border
- Punches are normally made from low-distortion or air-hardenable tool steel

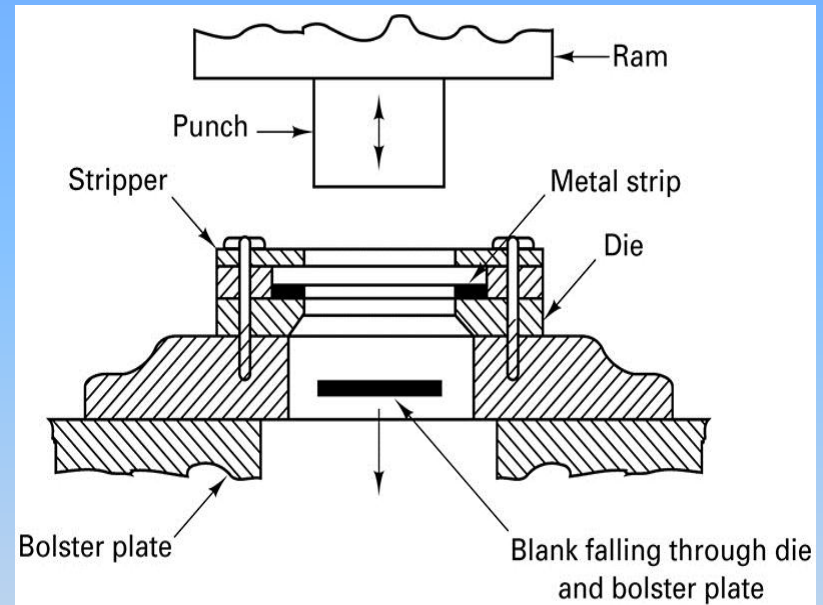
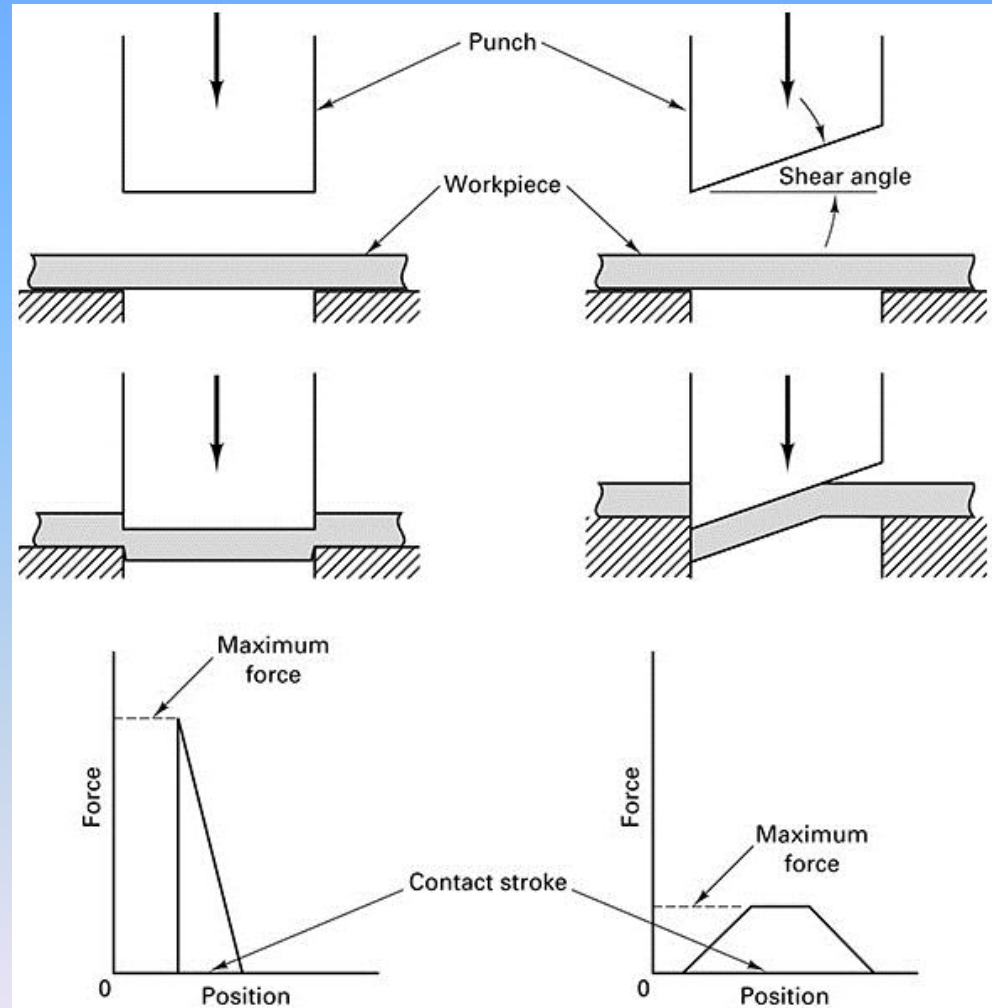

Figure 17-11 The basic components of piercing and blanking dies.

Blanking Operations

Figure 17-12 Blanking with a square-faced punch (left) and one containing angular shear (right). Note the difference in maximum force and contact stroke. The total work (the area under the curve) is the same for both processes.



Blanking Operations

Figure 17-13 (Below) Typical die set having two alignment guideposts.
(*Courtesy of Danly IEM, Cleveland, OH.*)

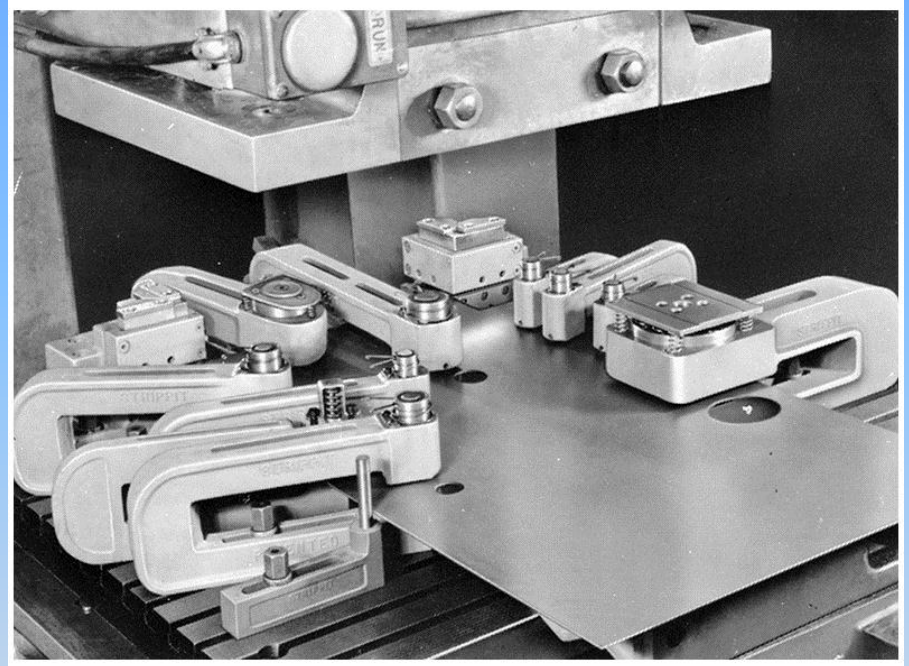

Figure 17-14 (Above) A piercing and blanking setup using self-contained subpress tool units.
(*Courtesy of Strippit Division, Houdaille Industries, Inc., Akron, NY.*)

Progressive Die Sets

- Progressive die sets- two or more sets of punches and dies mounted in tandem
- Transfer dies move individual parts from operation to operation within a single press
- Compound dies combine processes sequentially during a single stroke of the ram

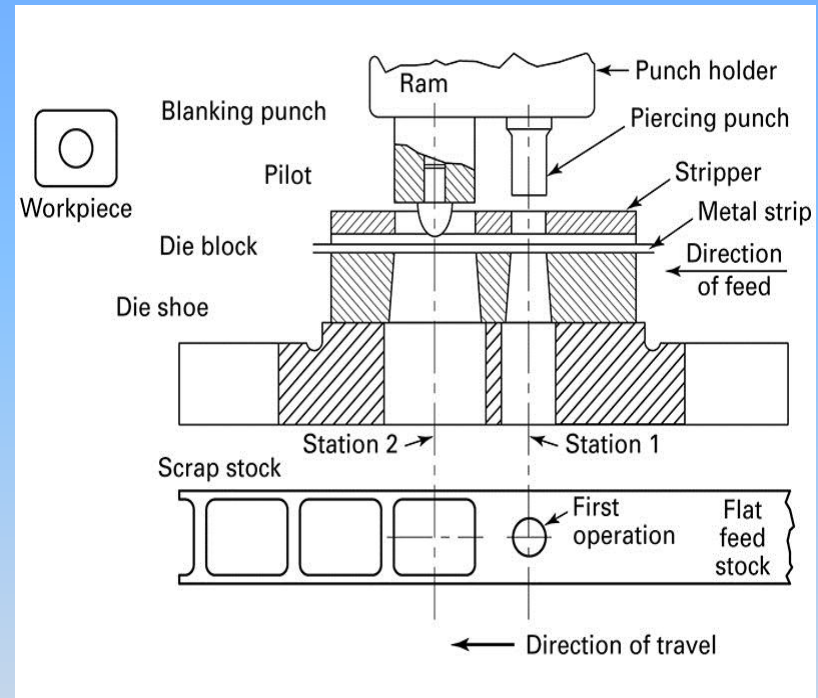

Figure 17-16 Progressive piercing and blanking die for making a square washer. Note that the punches are of different length.

Design Example

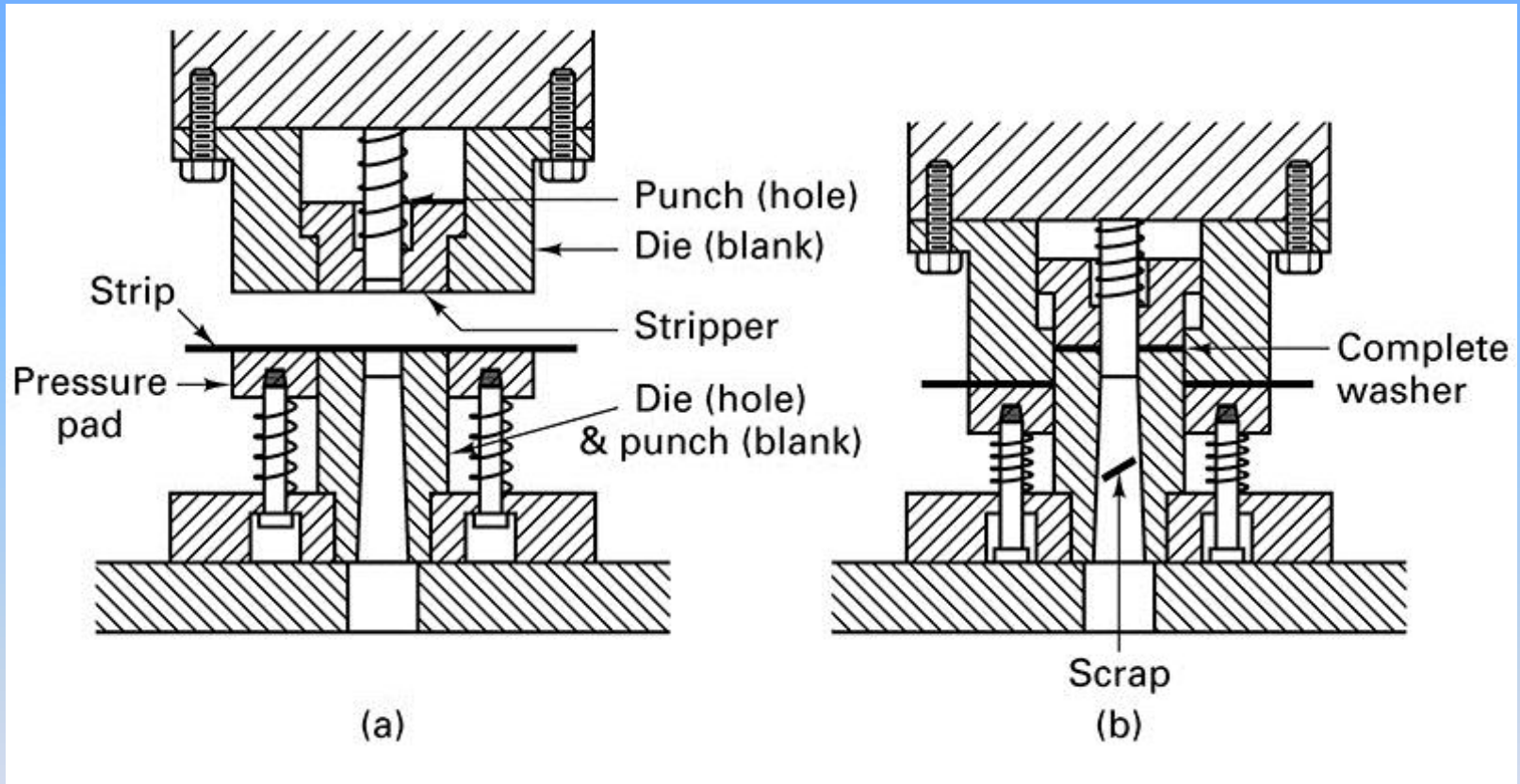

Figure 17-18 Method for making a simple washer in a compound piercing and blanking die. Part is blanked (a) and subsequently pierced (b) in the same stroke. The blanking punch contains the die for piercing.

Design for Piercing and Blanking

- Design rules
 - Diameters of pierced holes should not be less than the thickness of the metal
 - Minimum distance between holes or the edge of the stock should be at least equal to the metal thickness
 - The width of any projection or slot should be at least 1 times the metal thickness
 - Keep tolerances as large as possible
 - Arrange the pattern of parts on the strip to minimize scrap

17.3 Bending

- Bending is the plastic deformation of metals about a linear axis with little or no change in the surface area
- Forming- multiple bends are made with a single die
- Drawing and stretching- axes of deformation are not linear or are not independent
- Springback is the “unbending” that occurs after a metal has been deformed

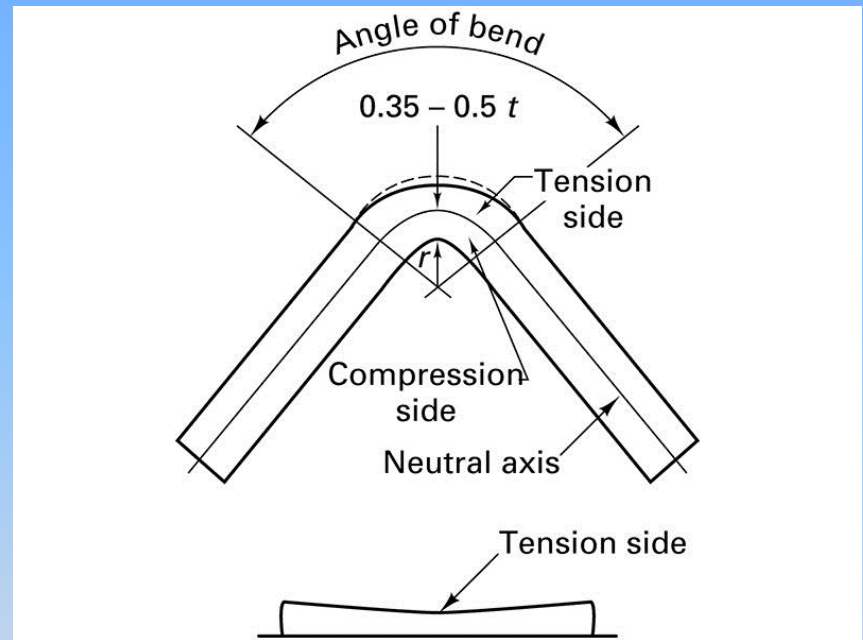

Figure 17-19 (Top) Nature of a bend in sheet metal showing tension on the outside and compression on the inside. (Bottom) The upper portion of the bend region, viewed from the side, shows how the center portion will thin more than the edges.

Angle Bending (Bar Folder and Press Brake)

- Bar folders make angle bends up to 150 degrees in sheet metal
- Press brakes make bends in heavier sheets or more complex bends in thin material

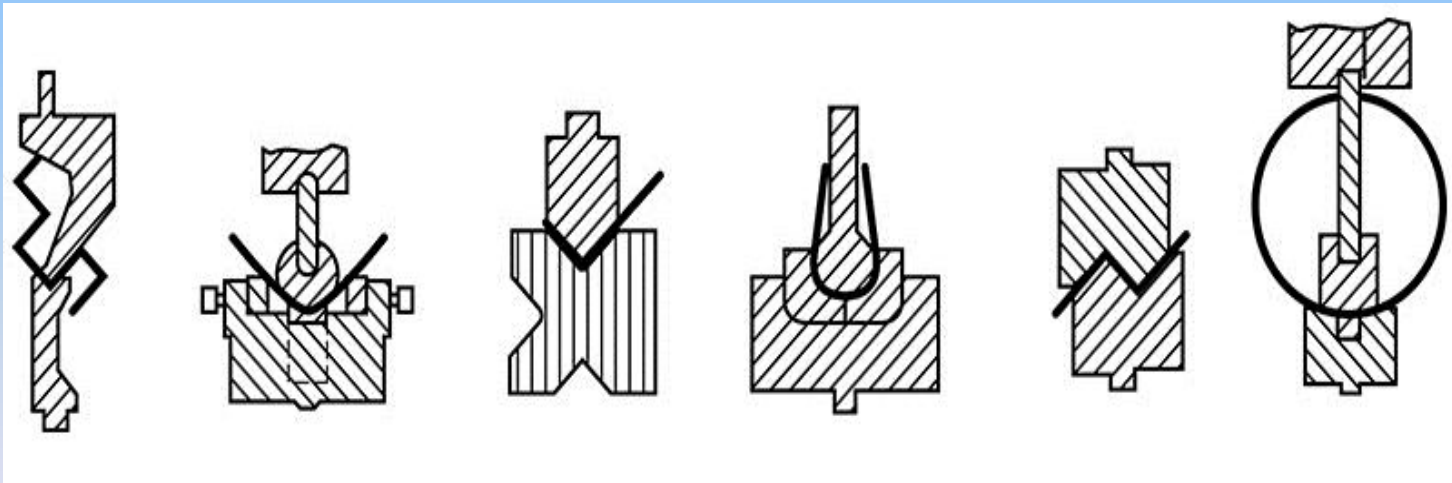

Figure 17-22 Press brake dies can form a variety of angles and contours. (Courtesy of Cincinnati Incorporated, Cincinnati, OH.)

Bar Folder

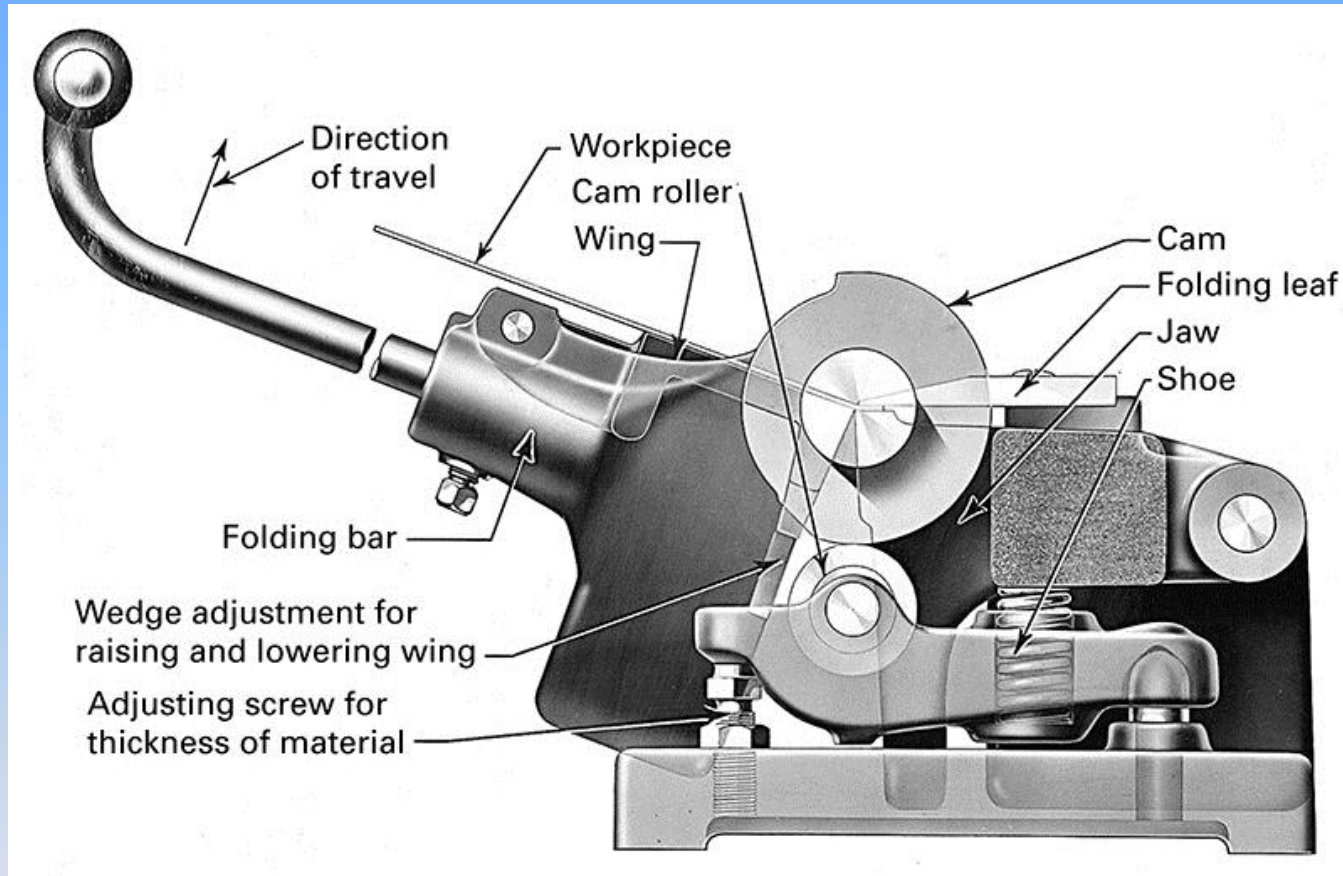

Figure 17-20 Phantom section of a bar folder, showing position and operation of internal components. (Courtesy of Niagara Machine and Tool Works, Buffalo, N.Y.)

Press Brake

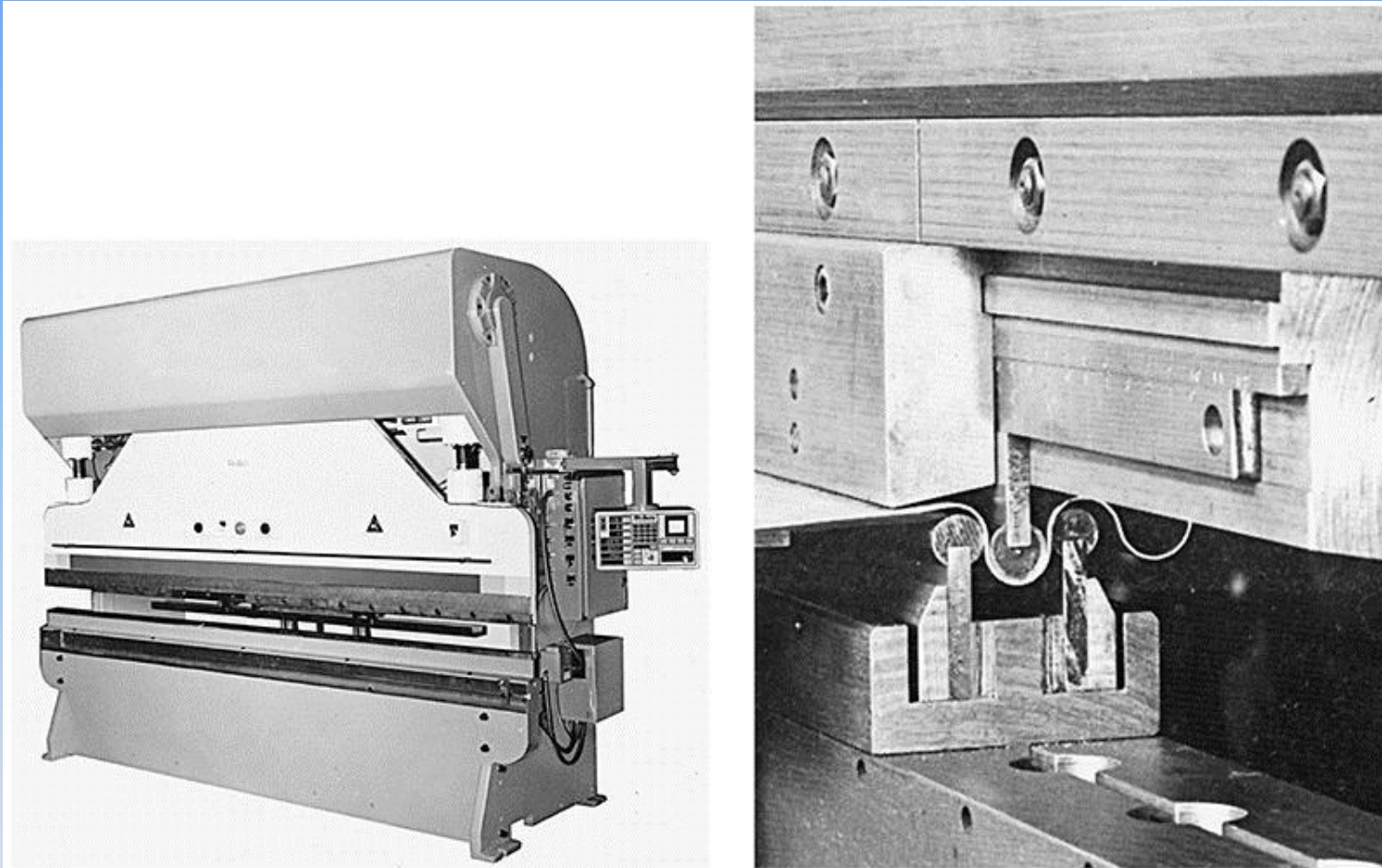

Figure 17-21 (Left) Press brake with CNC gauging system. (Courtesy of DiAcro Division, Acrotech Inc., Lake City, MN.) (Right) Close-up view of press brake dies forming corrugations. (Courtesy of Cincinnati Incorporated, Cincinnati, OH.)

Design for Bending

- Several factors are important in specifying a bending operation
 - Determine the smallest bend radius that can be formed without cracking the metal
 - Metal ductility
 - Thickness of material

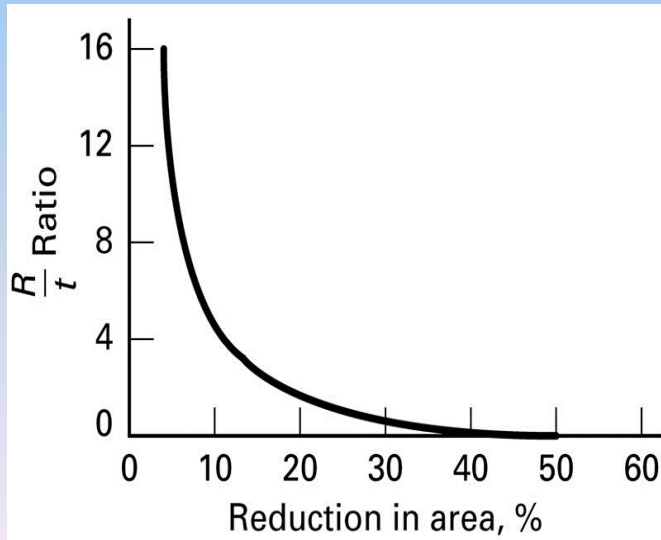

Figure 17-24 Relationship between the minimum bend radius (relative to thickness) and the ductility of the metal being bent (as measured by the reduction in area in a uniaxial tensile test).

Considerations for Bending

- If the punch radius is large and the bend angle is shallow, large amounts of springback are often encountered
- The sharper the bend, the more likely the surfaces will be stressed beyond the yield point

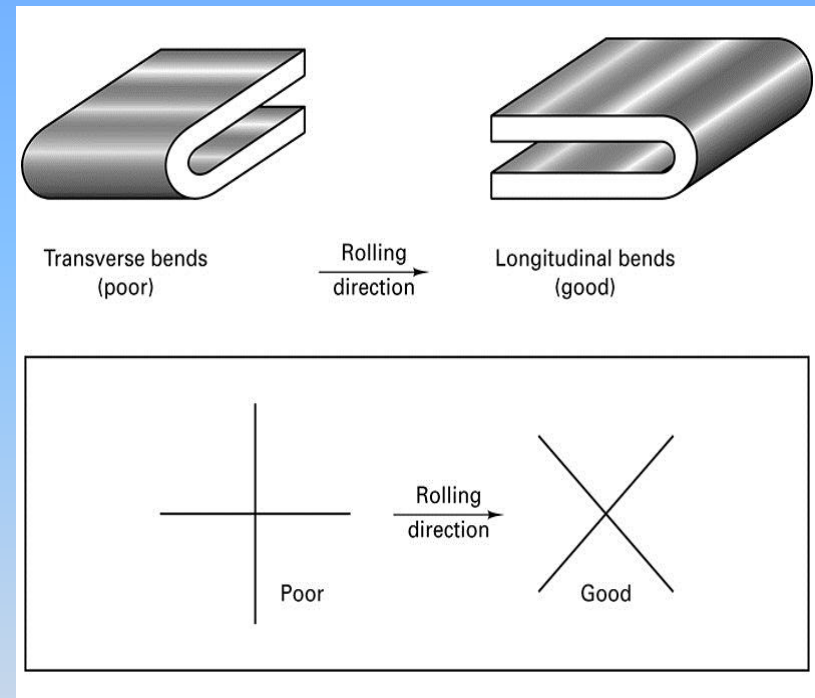

Figure 17-25 Bends should be made with the bend axis perpendicular to the rolling direction. When intersecting bends are made, both should be at an angle to the rolling direction, as shown.

Design Considerations

- Determine the dimensions of a flat blank that will produce a bent part of the desired precision
- Metal tends to thin when it is bent

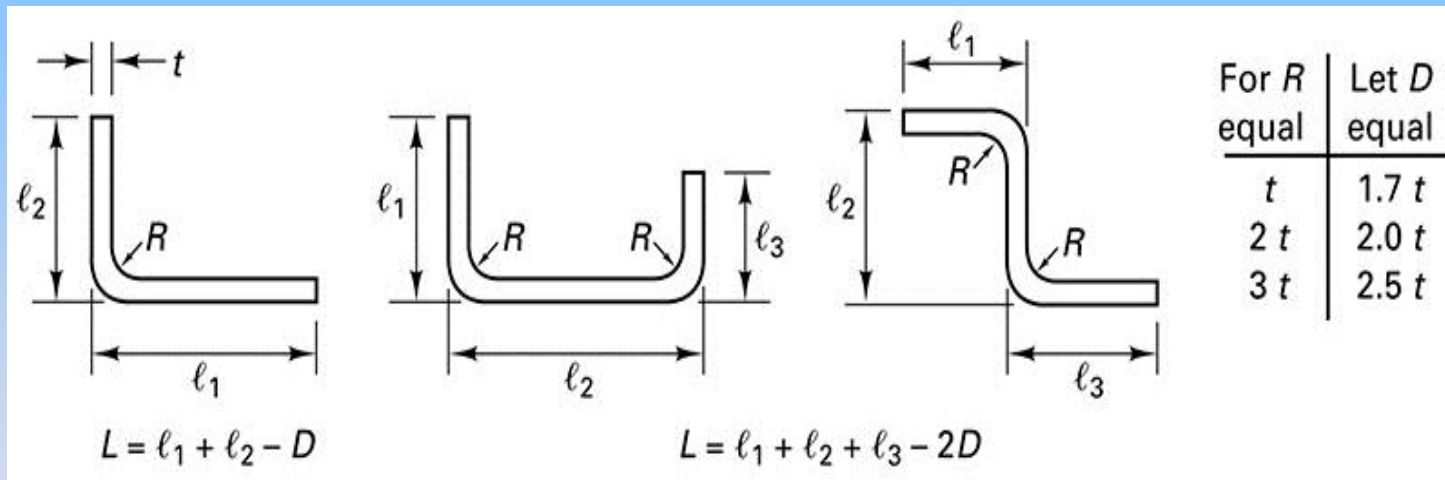

Figure 17-26 One method of determining the starting blank size (L) for several bending operations. Due to thinning, the product will lengthen during forming. l_1 , l_2 , and l_3 are the desired product dimensions. See table to determine D based on size of radius R where t is the stock thickness.

Air-Bend, Bottoming, and Coining Dies

- Bottoming dies contact and compress the full area within the tooling
 - Angle of the bend is set by the geometry of the tooling
- Air bend dies produce the desired geometry by simple three-point bending
- If bottoming dies go beyond the full-contact position, the operation is similar to coining

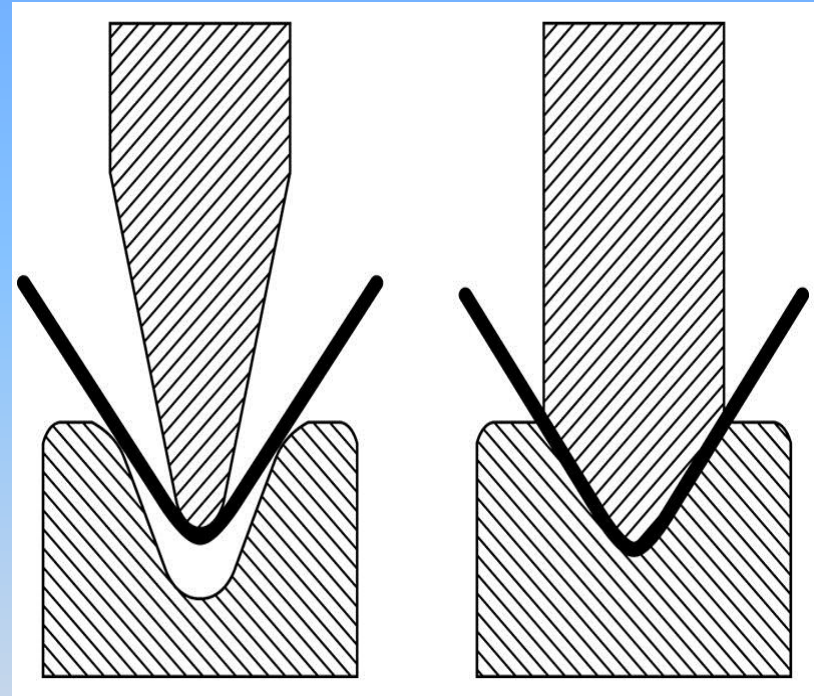

Figure 17-27 Comparison of air-bend (left) and bottoming (right) press brake dies. With the air-bend die, the amount of bend is controlled by the bottoming position of the upper die.

Roll Bending

- Roll bending is a continuous form of three-point bending
 - Plates, sheets, beams, pipes

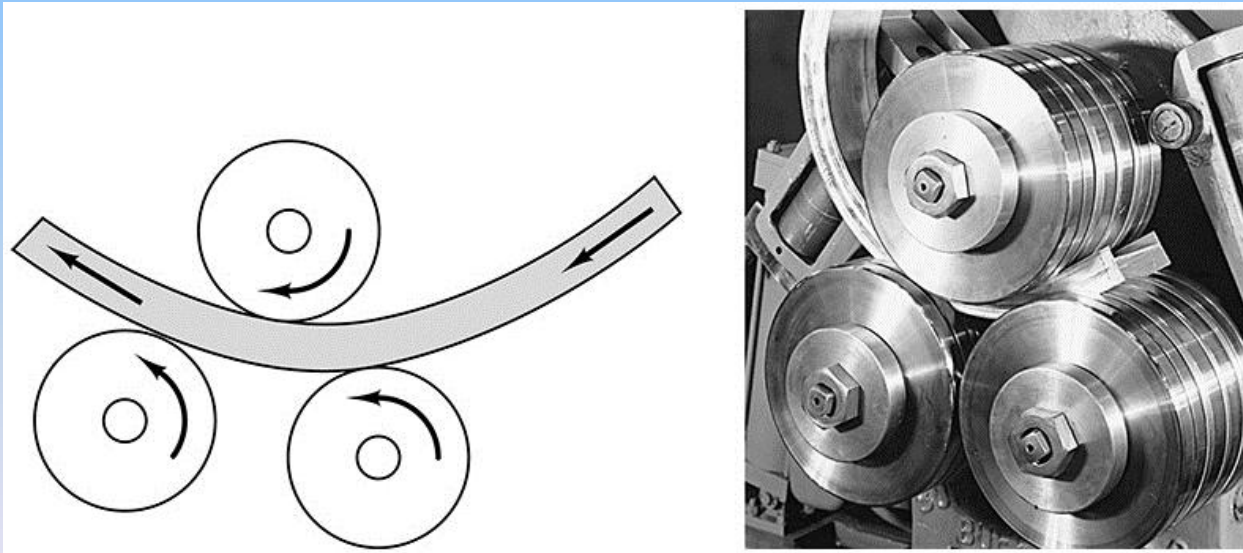

Figure 17-28 (Left) Schematic of the roll-bending process; (right) the roll bending of an I-beam section. Note how the material is continuously subjected to three-point bending. (Courtesy of Buffalo Forge Company, Buffalo, NY.)

Draw Bending, Compression Bending, and Press Bending

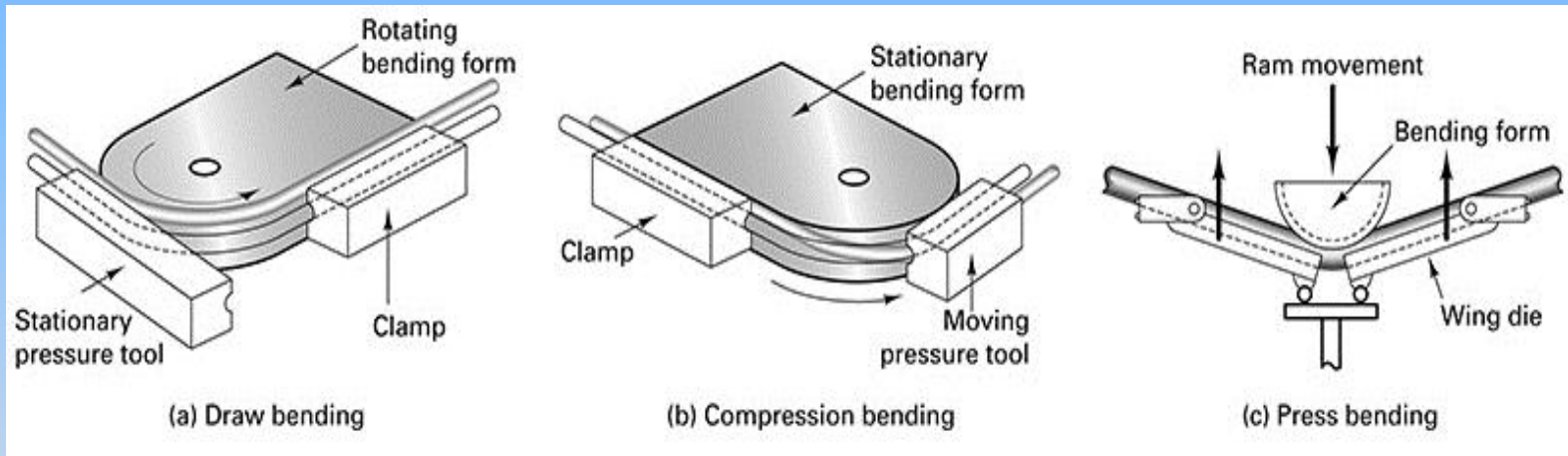
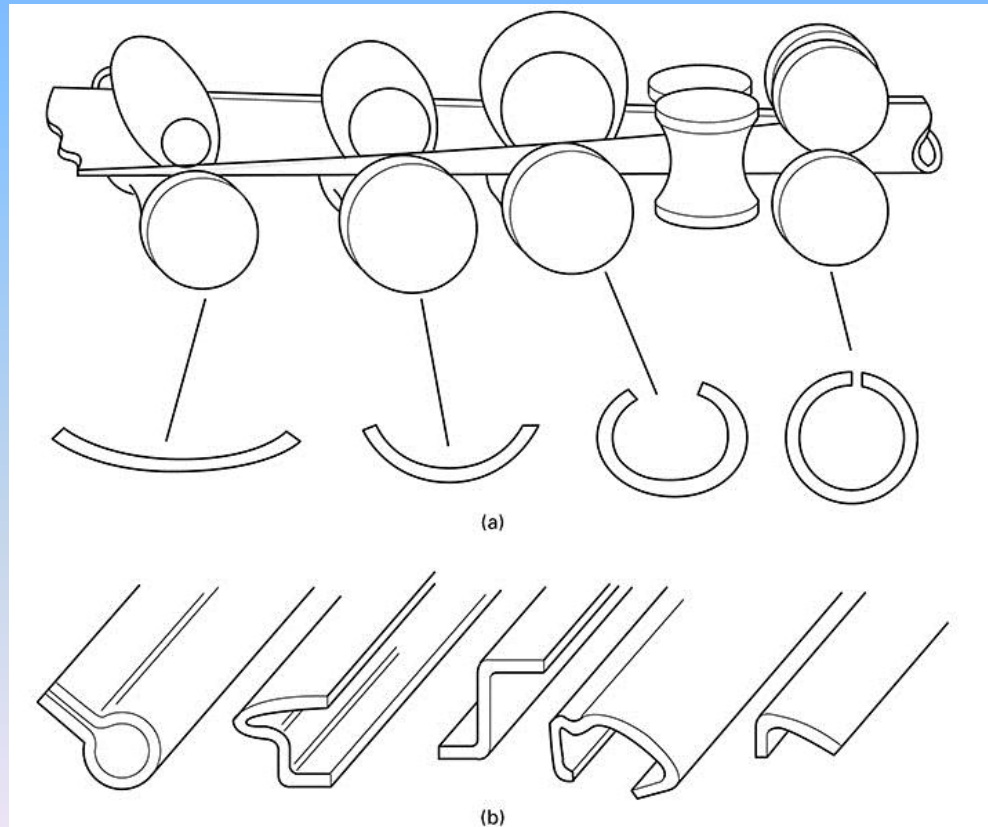

Figure 17-29 (a) Draw bending, in which the form block rotates; (b) compression bending, in which a moving tool compresses the workpiece against a stationary form; (c) press bending, where the press ram moves the bending form.

Tube Bending

- Key parameters: outer diameter of the tube, wall thickness, and radius of the bend



Roll Forming

- Roll forming is a process by which a metal strip is progressively bent as it passes through a series of forming rolls
- Only bending takes place during this process, and all bends are parallel to one another
- A wide variety of shapes can be produced, but changeover, setup, and adjustment may take several hours

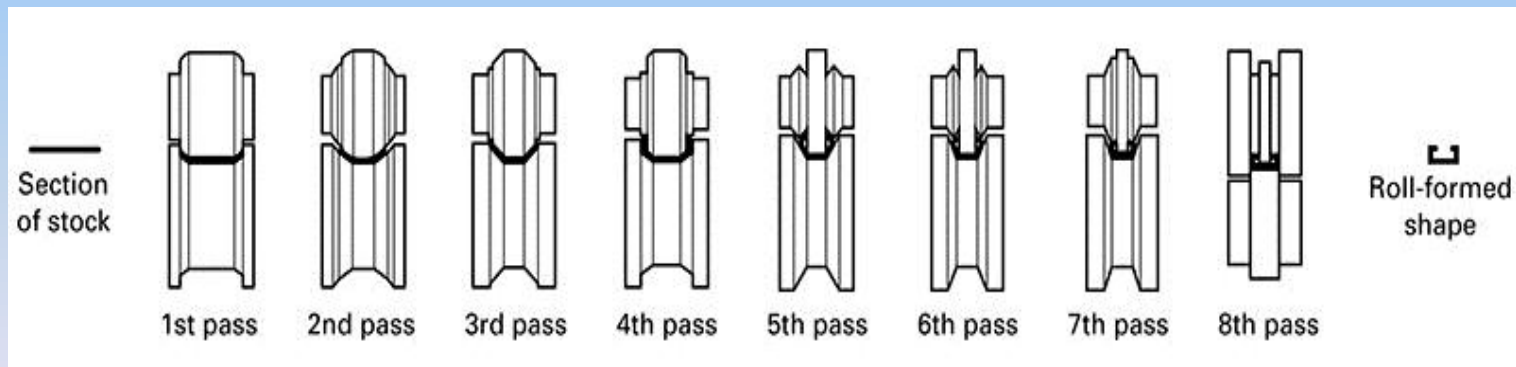

Figure 17-31 Eight-roll sequence for the roll forming of a box channel. (Courtesy of the Aluminum Association, Washington, DC.)

Seaming and Flanging

- Seaming is a bending operation that can be used to join the ends of sheet metal in some form of mechanical interlock
- Common products include cans, pails, drums, and containers
- Flanges can be rolled on sheet metal in a similar manner as seams

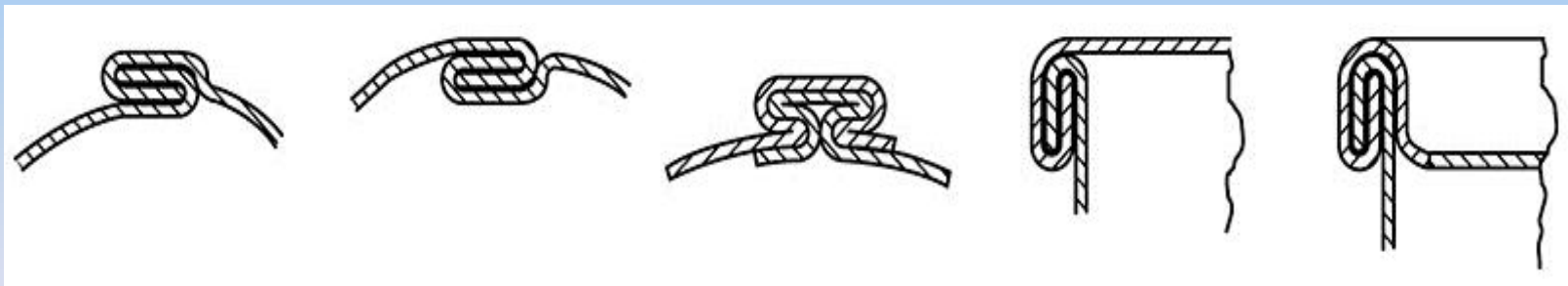

Figure 17-31 Various types of seams used on sheet metal.

Straightening

- Straightening or flattening is the opposite of bending
- Done before subsequent forming to ensure the use of flat or straight material
- Various methods to straighten material
 - Roll straightening (Roller leveling)
 - Stretcher leveling- material is mechanically gripped and stretch until it reaches the desired flatness

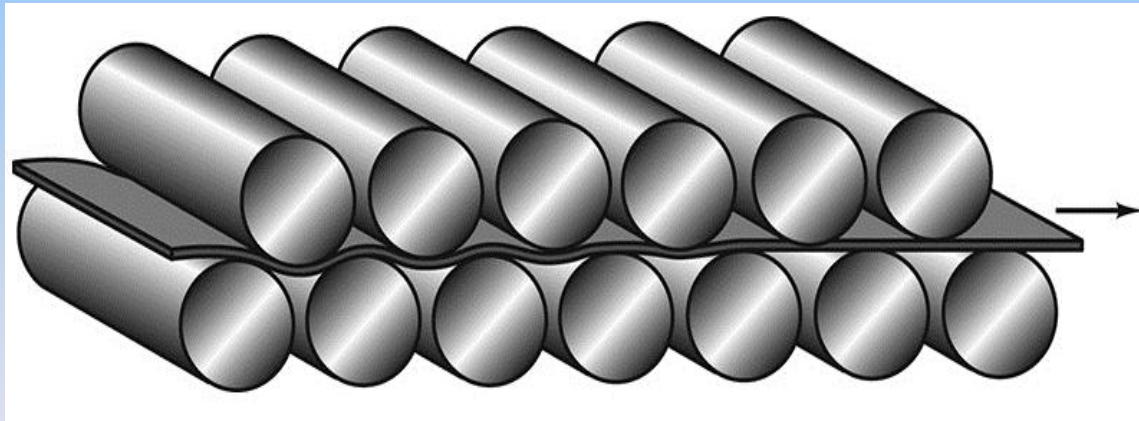

Figure 17-33 Method of straightening rod or sheet by passing it through a set of straightening rolls. For rods, another set of rolls is used to provide straightening in the transverse direction.

17.4 Drawing and Stretching Processes

- Drawing refers to the family of operations where plastic flow occurs over a curved axis and the flat sheet is formed into a three-dimensional part
- Spinning is a cold forming operation
 - Sheet metal is rotated and shaped over a male form, or mandrel
 - Produces rotationally symmetrical shapes
 - Spheres, hemispheres, cylinders, bells, and parabolas

Spinning

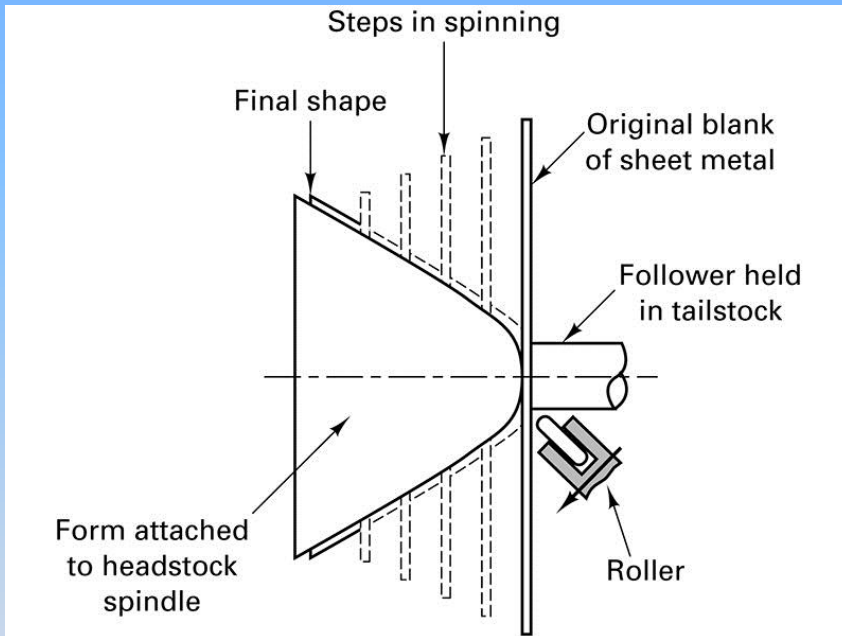
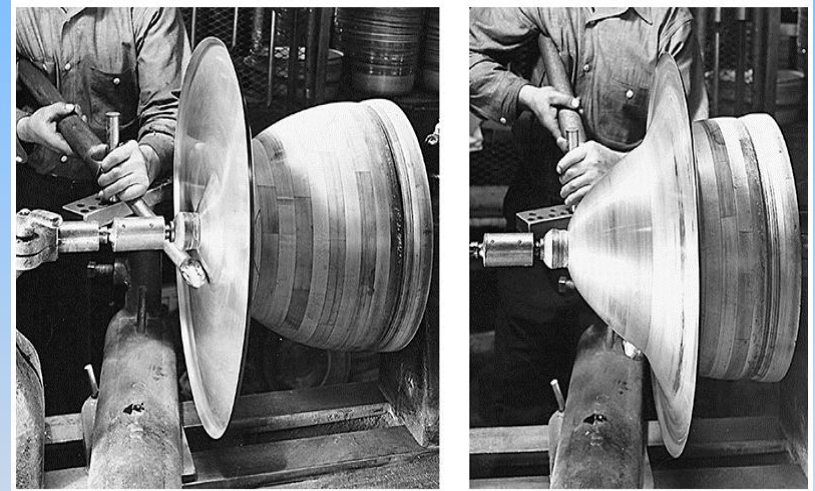

Figure 17-34 (Above) Progressive stages in the spinning of a sheet metal product.

Figure 17-35 (Below) Two stages in the spinning of a metal reflector. (Courtesy of *Spincraft, Inc. New Berlin, WI.*)



Shear Forming and Stretch Forming

- Shear forming is a version of spinning
- In sheet forming a sheet of metal is gripped and a form block shapes the parts

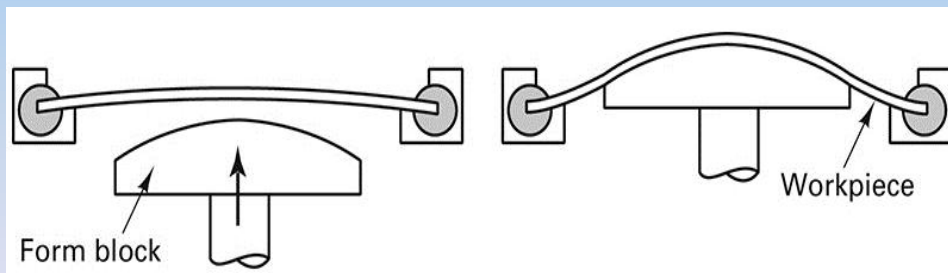

Figure 17-39 Schematic of a stretch-forming operation.

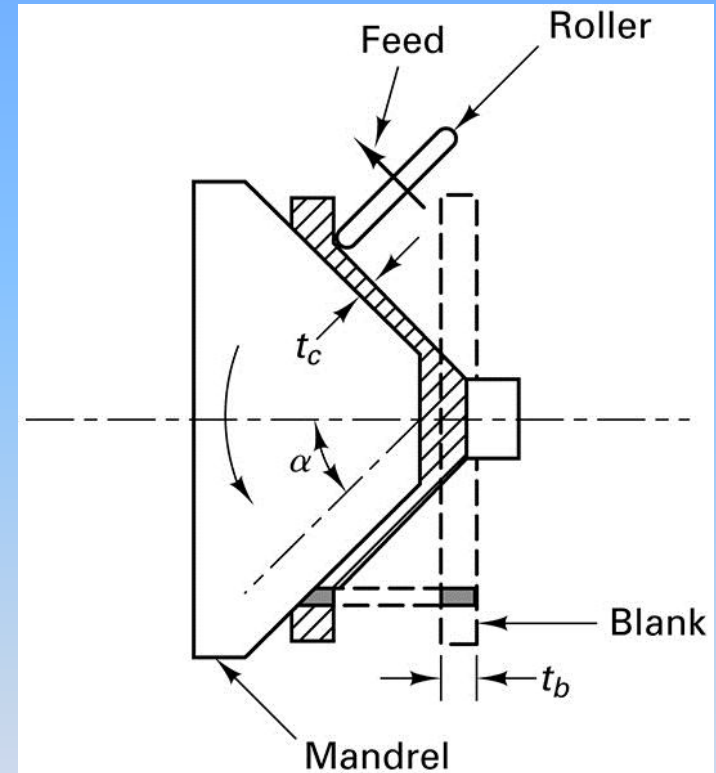

Figure 17-36 Schematic representation of the basic shear-forming process.

Deep Drawing and Shallow Drawing

- Deep drawing is typically used to form solid-bottom cylindrical or rectangular containers from sheet metal
- Key variables:
 - Blank and punch diameter
 - Punch and die radius
 - Clearance
 - Thickness of the blank
 - Lubrication
 - Hold-down pressure

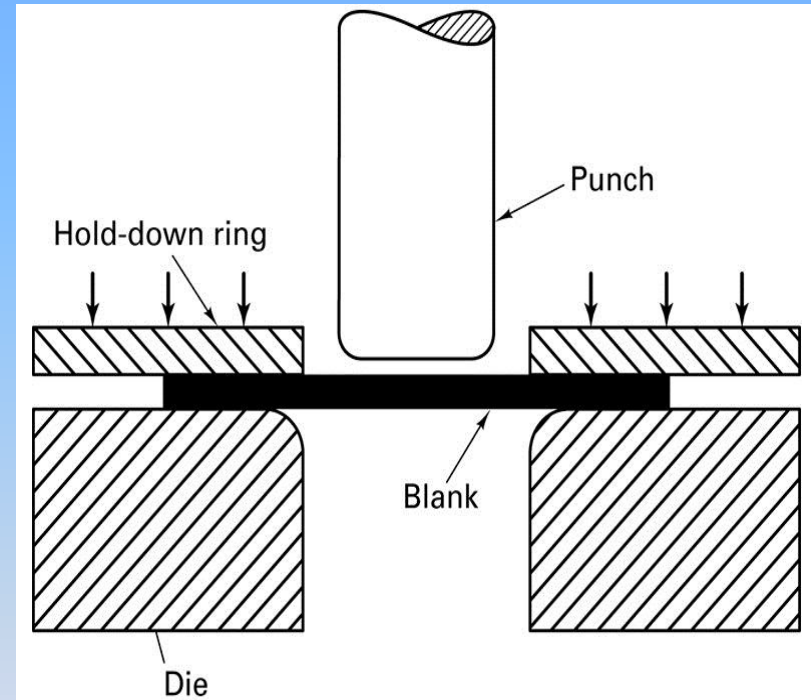

Figure 17-40 Schematic of the deep-drawing process.

Limitations of Deep Drawing

- Wrinkling and tearing are typical limits to drawing operations
- Different techniques can be used to overcome these limitations
 - Draw beads
 - Vertical projections and matching grooves in the die and blankholder
- Trimming may be used to reach final dimensions

Forming with Rubber Tooling or Fluid Pressure

- Blanking and drawing operations usually require mating male and female die sets
- Processes have been developed that seek to
 - Reduce tooling cost
 - Decrease setup time and expense
 - Extend the amount of deformation for a single set of tools

Alternative Forming Operations

- Several forming operations replace one of the dies with rubber or fluid pressure
 - Guerin process
- Other forming operations use fluid or rubber to transmit the pressure required to expand a metal blank
 - Bulging

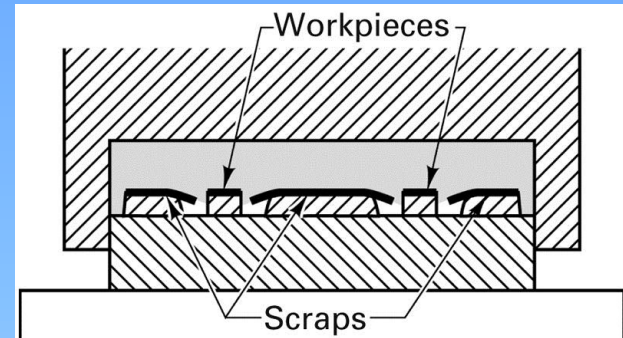

Figure 17-47 Method of blanking sheet metal using the Guerin process.

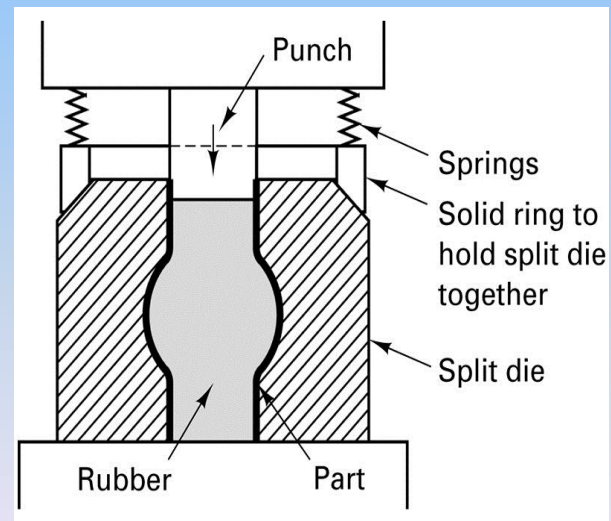

Figure 17-48 Method of bulging tubes with rubber tooling.

Sheet Hydroforming

- Sheet hydroforming is a family of processes in which a rubber bladder backed by fluid pressure replaces either the solid punch or female die set
- Advantages
 - Reduced cost of tooling
 - Deeper parts can be formed without fracture
 - Excellent surface finish
 - Accurate part dimensions

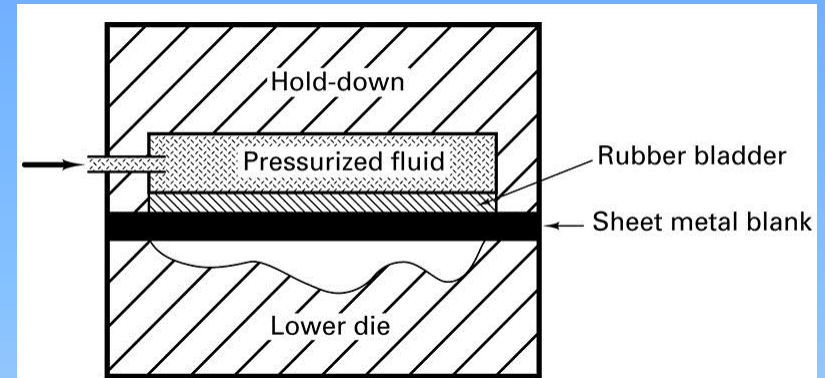

Figure 17-50 (Above) One form of sheet hydroforming.

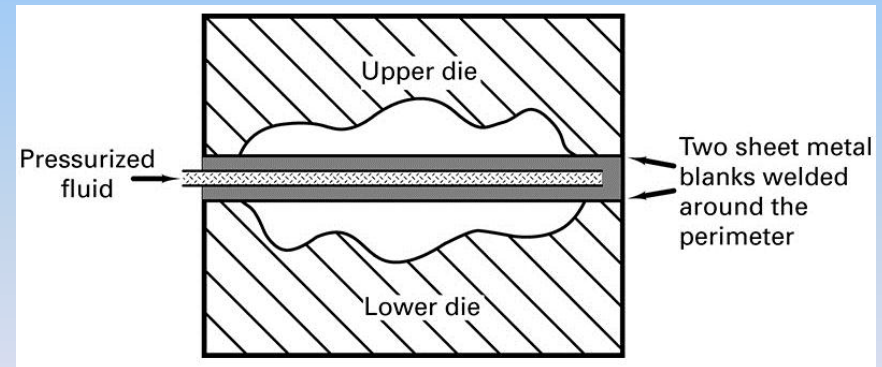

Figure 17-51 Two-sheet hydroforming, or pillow forming.

Tube Hydroforming

- Process for manufacturing strong, lightweight, tubular components
- Frequently used process for automotive industry
- Advantages
 - Lightweight, high-strength materials
 - Designs with varying thickness or varying cross section can be made
 - Welded assemblies can be replaced by one-piece components
- Disadvantages
 - Long cycle time
 - Relatively high tooling cost and process setup

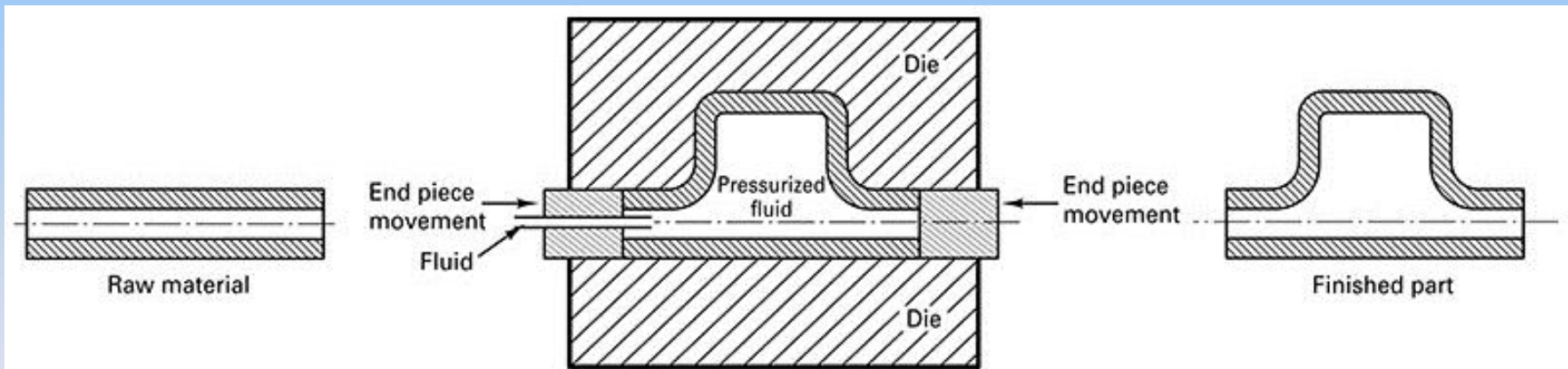

Figure 17-52 Tube hydroforming. (a) Process schematic.

Additional Drawing Operations

- Hot-drawing
 - Sheet metal has a large surface area and small thickness, so it cools rapidly
 - Most sheet forming is done at mildly elevated temperatures
- High-Energy Rate Forming
 - Large amounts of energy in a very short time
 - Underwater explosions, underwater spark discharge, pneumatic-mechanical means, internal combustion of gaseous mixtures, rapidly formed magnetic fields
- Ironing
 - Process that thins the walls of a drawn cylinder by passing it between a punch and a die

Additional Drawing Operations

- Embossing
 - Pressworking process in which raised lettering or other designs are impressed in sheet material
- Superplastic sheet forming
 - Materials that can elongate in the range of 2000 to 3000% can be used to form large, complex-shaped parts
 - Superplastic forming techniques are similar to that of thermoplastics

Properties of Sheet Material

- Tensile strength of the material is important in determining which forming operations are appropriate
- Sheet metal is often anisotropic- properties vary with direction or orientation
- Majority of failures during forming occur due to thinning or fracture
- Strain analysis can be used to determine the best orientation for forming

17.5 Alternative Methods of Producing Sheet-Type Products

- Electroforming
 - Directly deposits metal onto preshaped forms or mandrels
 - Nickel, iron, copper, or silver can be used
 - A wide variety of sizes and shapes can be made by electroforming
- Spray forming
 - Spray deposition
 - Uses powdered material in a plasma torch
 - Molten metal may also be sprayed

17.6 Pipe Welding

- Skelp is long strips of steel used in welding
- Butt-welded pipe
 - Steel skelp is heated to a specified hot-working temperature
 - The skelp rolls back on each other through rollers and produces a welded seam
- Lap-welded pipe
 - Skelp has beveled edges and the rolls form the weld by forcing the lapped edges down

17.7 Presses

TABLE 17-2 Classification of the Drive Mechanisms of Commercial Presses

Manual	Mechanical	Hydraulic
Kick presses	Crank Single Double Eccentric Cam Knuckle joint Toggle Screw Rack and pinion	Single slide Multiple slide

Figure 17-58 Schematic representation of the various types of press drive mechanisms.

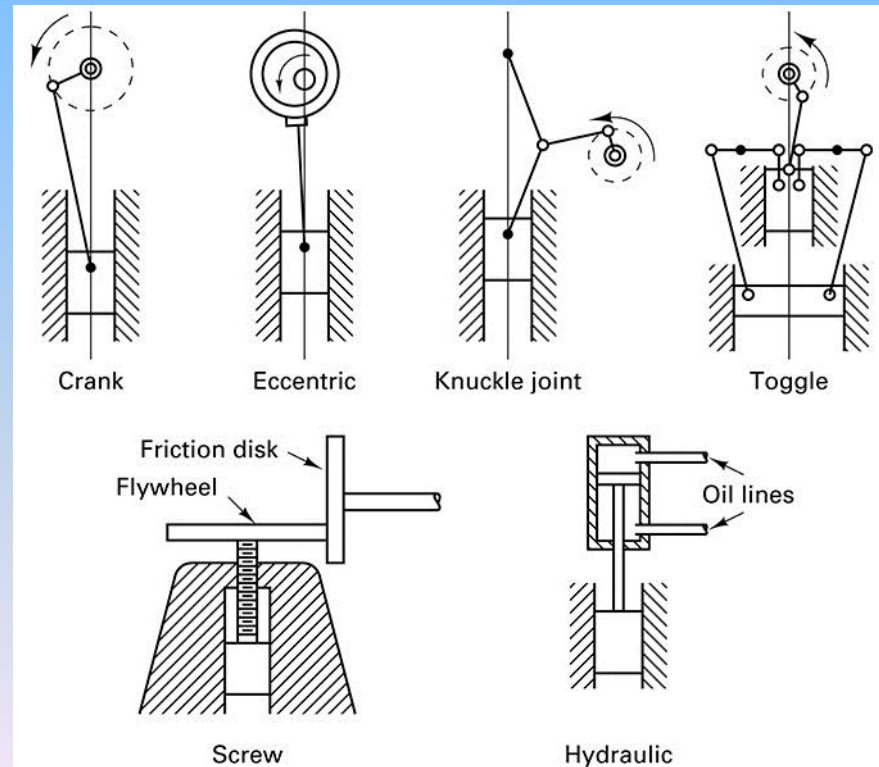

Types of Press Frame

TABLE 17-3 Classification of Presses According to Type of Frame

Arch	Gap	Straight Sided
Crank or eccentric Percussion	Foot Bench Vertical Inclinable Inclinable Open back Horn Turret	Many variations, but all with straight-sided frames



Figure 17-60 (Left) Inclinable gap-frame press with sliding bolster to accommodate two die sets for rapid change of tooling. (Courtesy of Niagara Machine & Tool Works, Buffalo, NY.)

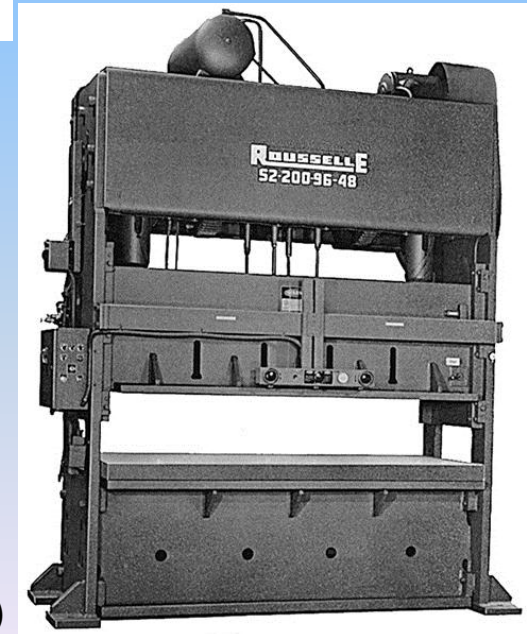

Figure 17-61 (Right) A 200-ton (1800-kN) straight-sided press. (Courtesy of Roussele Corporation, West Chicago, IL.)

Special Types of Presses

- Presses have been designed to perform specific types of operations
- Transfer presses have a long moving slide that enables multiple operations to be performed simultaneously in a single machine
- Four-slide or multislides machines are used to produce small, intricately shaped parts from continuously fed wire or coil strip

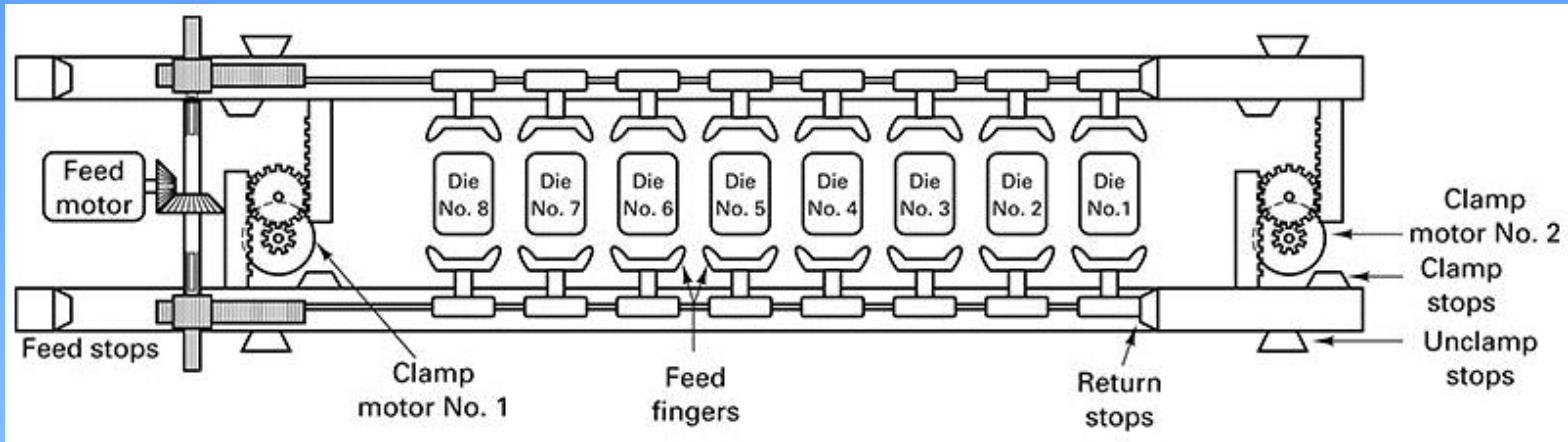

Figure 17-62 Schematic showing the arrangement of dies and the transfer mechanism used in transfer presses. (Courtesy of Verson Allsteel Press Company, Chicago, IL.)

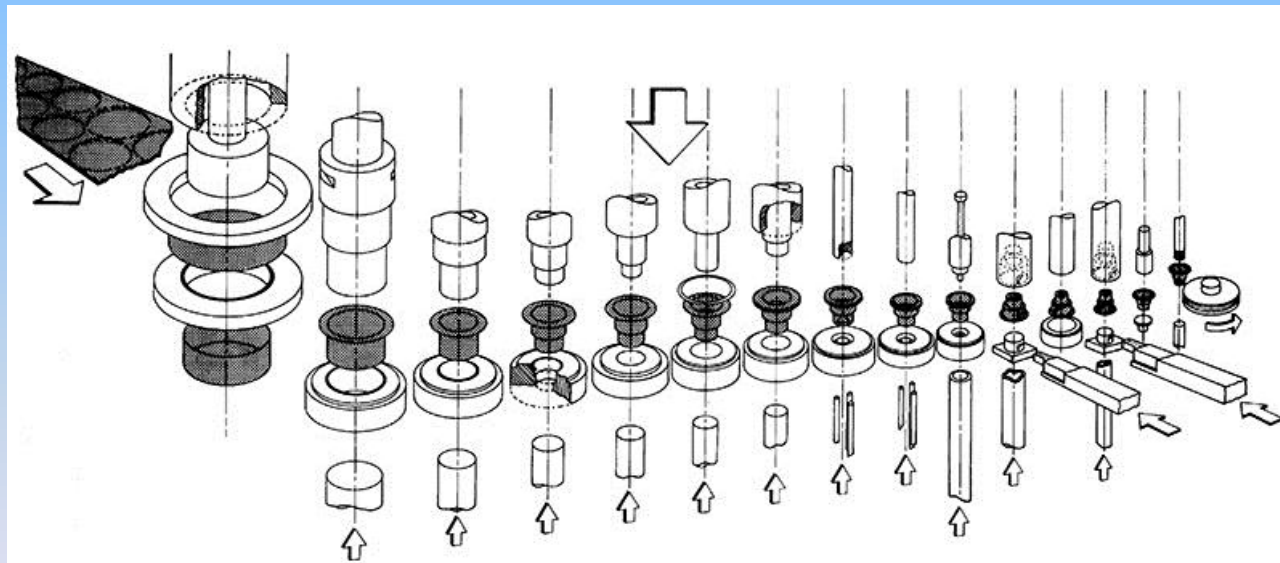

Figure 17-63 Various operations can be performed during the production of stamped and drawn parts on a transfer press. (Courtesy of U.S. Baird Corporation, Stratford, CT.)

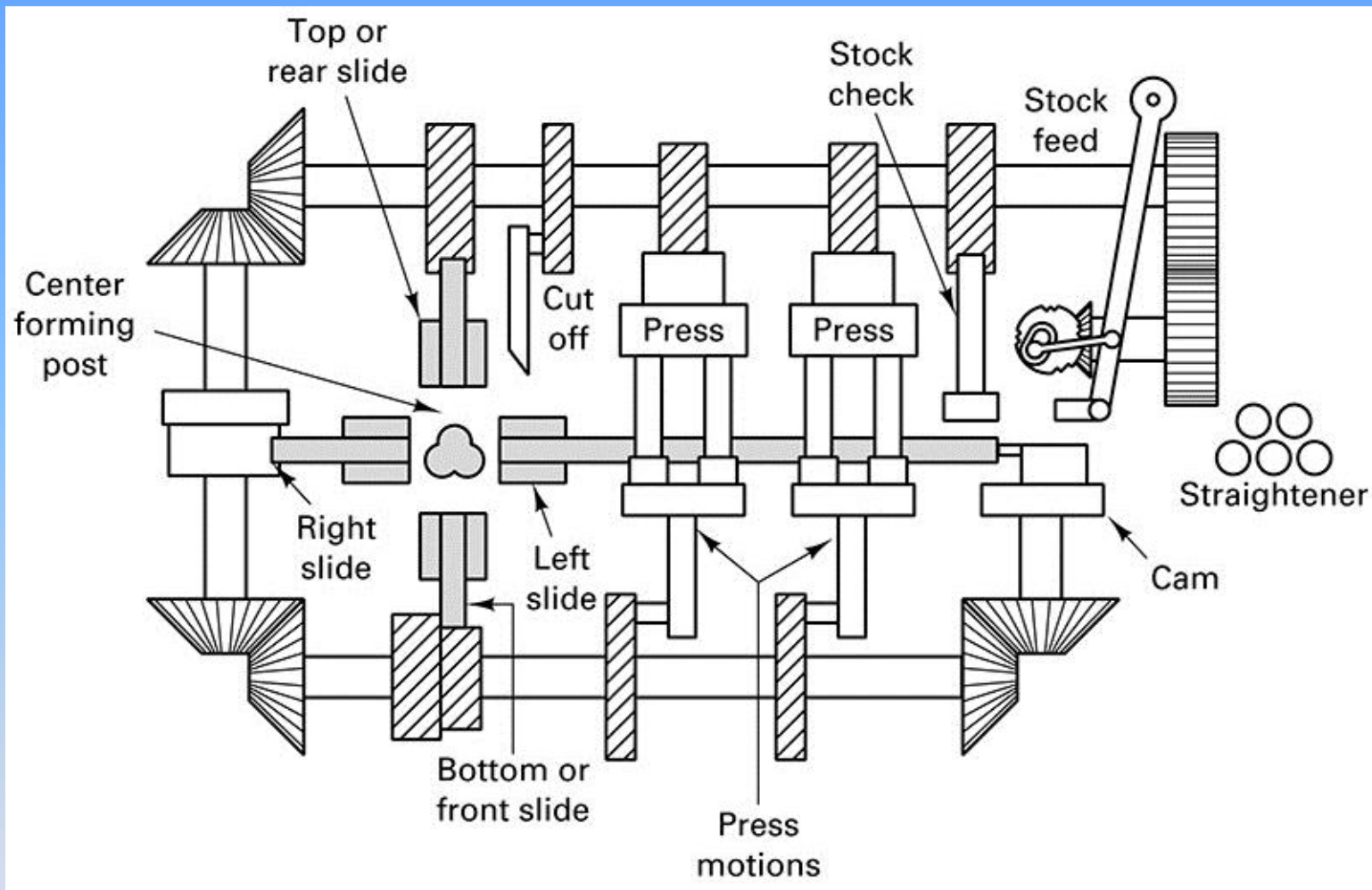

Figure 17-65 Schematic of the operating mechanism of a multislide machine. The material enters on the right and progresses toward the left as operations are performed. (Courtesy of U.S. Baird Corporation, Stratford, CT.)

Summary

- Sheet forming processes can be grouped in several broad categories
 - Shearing
 - Bending
 - Drawing
 - Forming
- Basic sheet forming operations involve a press, punch, or ram and a set of dies
- Material properties, geometry of the starting material, and the geometry of the desired final product play important roles in determining the best process