

Powder Metallurgy

Chapter 18

18.1 Introduction

- Powder metallurgy is the name given to the process by which fine powdered materials are blended, pressed into a desired shape, and then heated to bond surfaces
- Typically used when large amounts of small, intricate parts with high precision are required
- Little material waste and unusual mixtures can be utilized
- Used for parts in the automotive industry, household appliances, and recreational equipment (to name a few)

18.2 The Basic Process

- Four basic steps
 - 1. Powder manufacture
 - 2. Mixing or blending
 - 3. Compacting
 - 4. Sintering

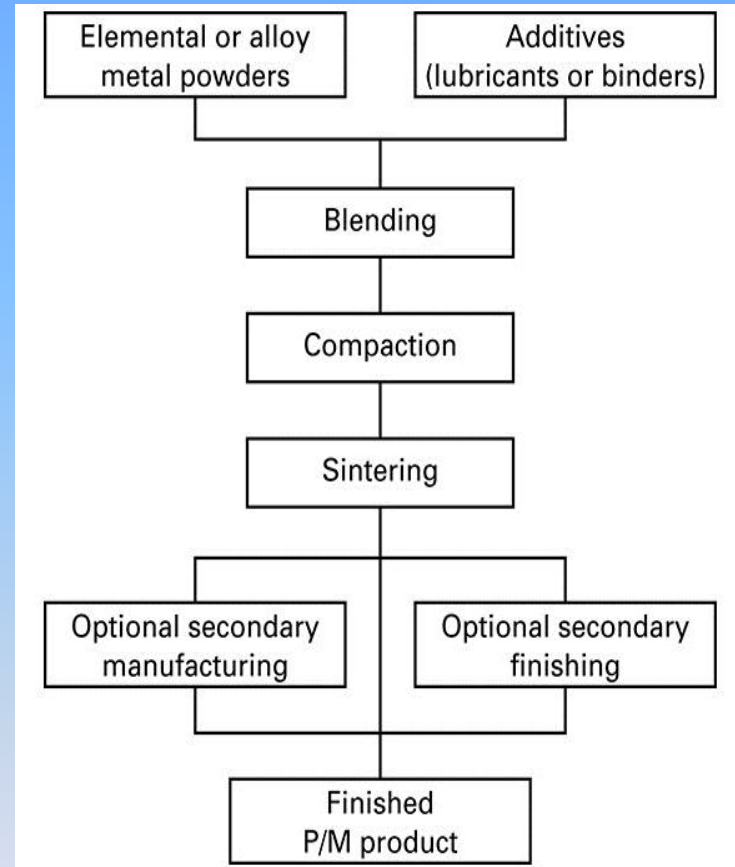

Figure 18-1 Simplified flow chart of the basic powder metallurgy process.

18.3 Powder Manufacture

- Properties of powder metallurgy products are highly dependent on the characteristics of starting powders
- Some important properties and characteristics
 - Chemistry and purity
 - Particle size
 - Size distribution
 - Particle shape
 - Surface texture
- Useful in producing prealloyed powders
 - Each powder particle can have the desired alloy composition

Powder Manufacture

- The majority of commercial powder is produced by some form of melt atomization
 - Atomization is a process where liquid metal is fragmented into small droplets that cool and solidify into particles

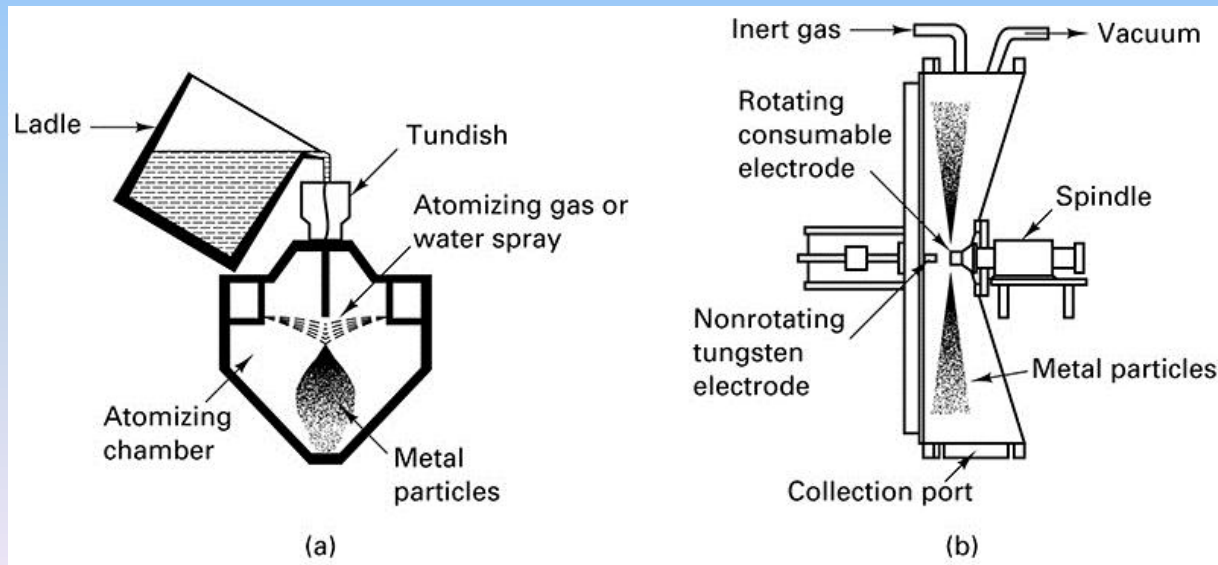

Figure 18-2 Two methods for producing metal powders: (a) melt atomization and (b) atomization from a rotating consumable electrode.

Additional Methods of Powder Manufacture

- Methods
 - Chemical reduction of particulate compounds
 - Electrolytic deposition
 - Pulverization or grinding
 - Thermal decomposition of particulate hydrides
 - Precipitation from solution
 - Condensation of metal vapors
- Almost any metal or alloy can be converted into powder

18.4 Rapidly Solidified Powder (Microcrystalline and Amorphous)

- If the cooling rate of an atomized liquid is increased, ultra-fine or microcrystalline sized grains can form
- Some metals can solidify without becoming crystalline (called amorphous materials)
- Amorphous materials can have high strength, improved corrosion resistance, and reduced energy to induce and reverse magnetization

18.5 Powder Testing and Evaluation

- Powders should be evaluated for their suitability for further processing
- *Flow rate* measures the ease with which powder can be fed and distributed into a die
- *Apparent density* is the measure of a powder's ability to fill available space without external pressure
- *Compressibility* is the effectiveness of applied pressure
- *Green strength* is used to describe the strength of the pressed powder after compacting

18.6 Powder Mixing and Blending

- The majority of powders are mixed with other powders, binders, and lubricants to achieve the desired characteristics in the finished product
- Sufficient diffusion must occur during sintering to ensure a uniform chemistry and structure
- Unique composites can be produced
- Blending or mixing operations can be done either wet or dry

18.7 Compacting

- Loose powder is compacted and densified into a shape, known as green compact
- Most compacting is done with mechanical presses and rigid tools
 - Hydraulic and pneumatic presses are also used

TABLE 18-1 Typical Compacting Pressures for Various Applications

Application	Compaction Pressures	
	tons/in. ²	Mpa
Porous metals and filters	3–5	40–70
Refractory metals and carbides	5–15	70–200
Porous bearings	10–25	146–350
Machine parts (medium-density iron & steel)	20–50	275–690
High-density copper and aluminum parts	18–20	250–275
High-density iron and steel parts	50–120	690–1650



Figure 18-3 (Left) Typical press for the compacting of metal powders. A removable die set (right) allows the machine to be producing parts with one die set while another is being fitted to produce a second product. (Courtesy of Alfa Laval, Inc., Warminster, PA.)

Compaction Sequence

- Powders do not flow like liquid, they simply compress until an equal and opposing force is created
 - This opposing force is created from a combination of (1) resistance by the bottom punch and (2) friction between the particles and die surface

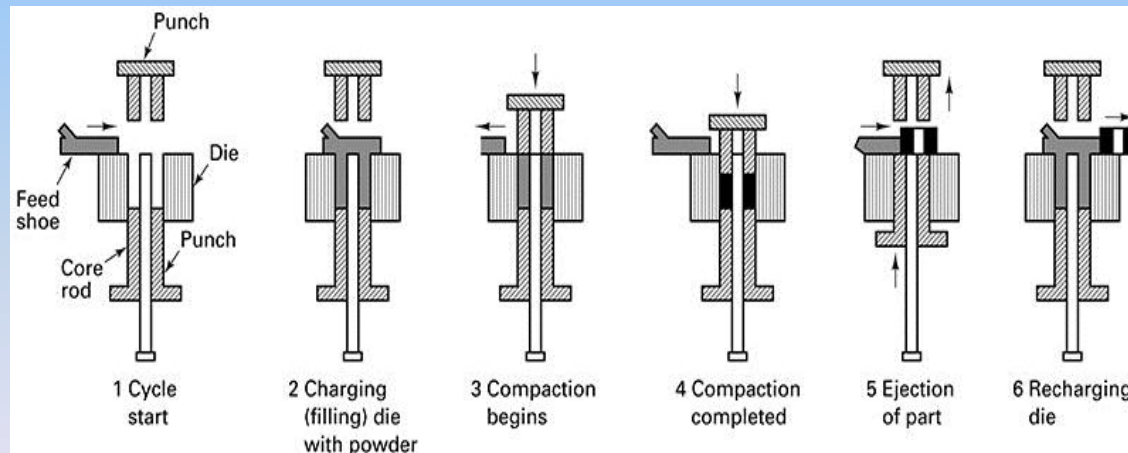

Figure 18-4 Typical compaction sequence for a single-level part, showing the functions of the feed shoe, die core rod, and upper and lower punches. Loose powder is shaded; compacted powder is solid black.

Additional Considerations During Compacting

- When the pressure is applied by only one punch, the maximum density occurs right below the punch surface and decreases away from the punch
- For complex shapes, multiple punches should be used

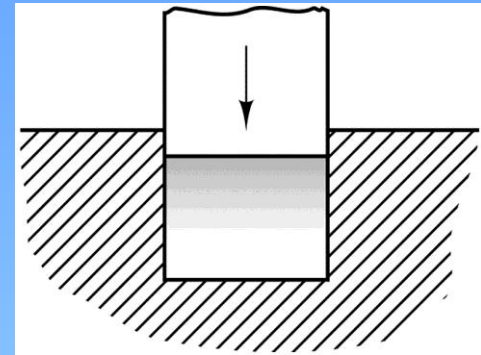

Figure 18-5 Compaction with a single moving punch, showing the resultant nonuniform density (shaded), highest where particle movement is the greatest.

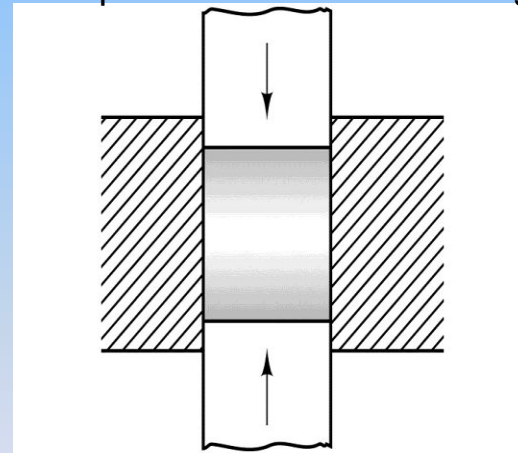

Figure 18-6 Density distribution obtained with a double-acting press and two moving punches. Note the increased uniformity compared to Figure 18-5. Thicker parts can be effectively compacted.

Effects of Compacting

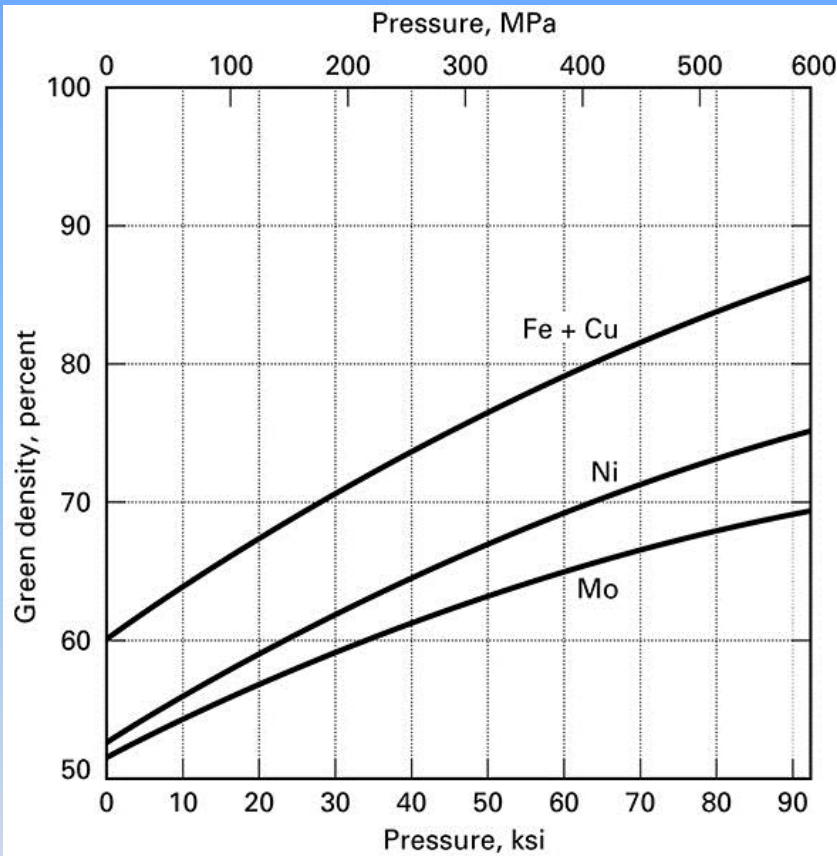

Figure 18-7 Effect of compacting pressure on green density (the density after compaction but before sintering). Separate curves are for several commercial powders.

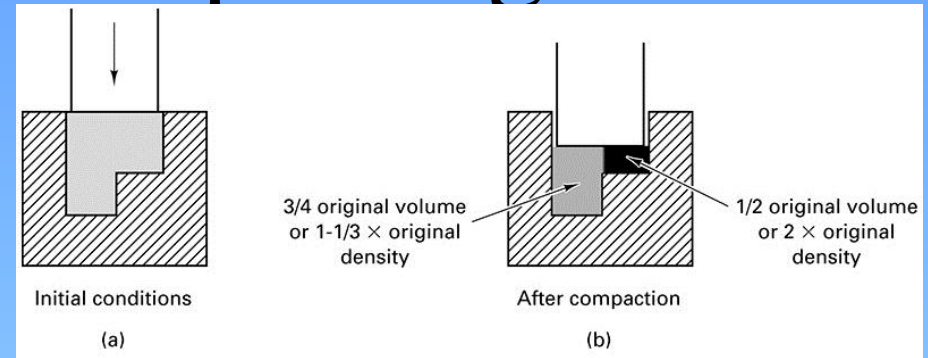

Figure 18-8 Compaction of a two-thickness part with only one moving punch. (a) Initial conditions; (b) after compaction by the upper punch. Note the drastic difference in compacted density.

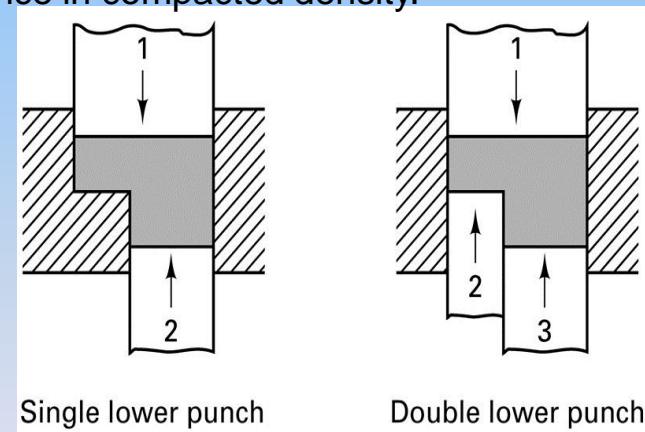
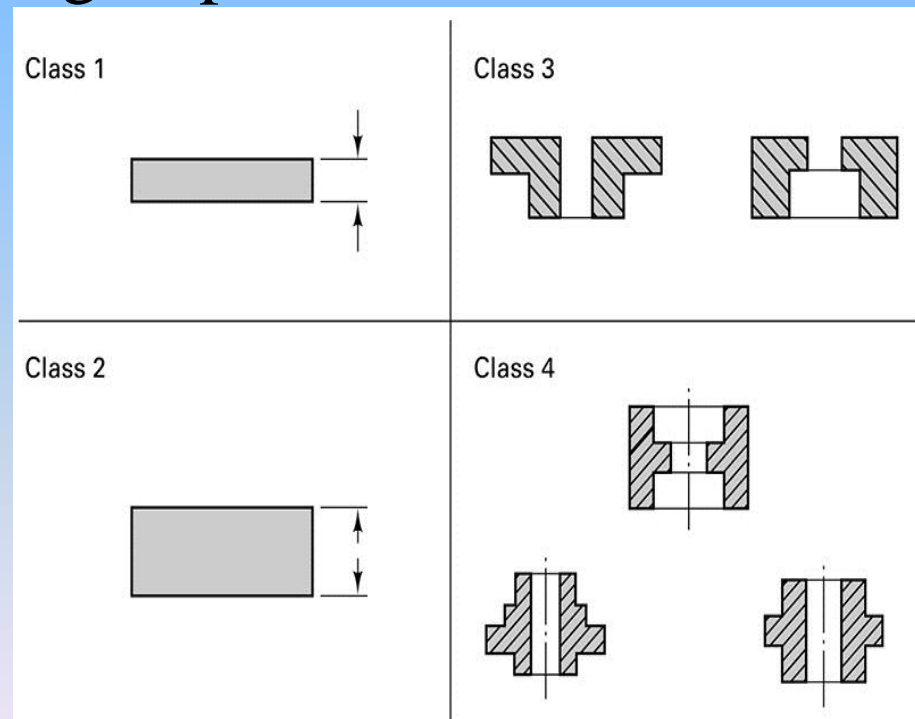

Figure 18-9 Two methods of compacting a double-thickness part to near-uniform density. Both involve the controlled movement of two or more punches.

Classes of Powder Metallurgy Equipment

- The complexity of the part dictates the complexity of equipment
- Equipment has been grouped into classes

Figure 18-10 Sample geometries of the four basic classes of press-and-sinter powder metallurgy parts. Note the increased pressing complexity that would be required as class increases.



Complex Compacting

- If an extremely complex shape is desired, the powder may be encapsulated in a flexible mold, which is then immersed in a pressurized gas or liquid
 - Process is known as isostatic compaction
- In warm compaction, the powder is heated prior to pressing
- The amount of lubricant can be increased in the powder to reduce friction
- Because particles tend to be abrasive, tool wear is a concern in powder forming

18.8 Sintering

- In the sintering operation, the pressed-powder compacts are heated in a controlled atmosphere to right below the melting point
- Three stages of sintering
 - Burn-off (purge)- combusts any air and removes lubricants or binders that would interfere with good bonding
 - High-temperature- desired solid-state diffusion and bonding occurs
 - Cooling period- lowers the temperature of the products in a controlled atmosphere
- All three stages must be conducted in oxygen-free conditions

18.9 Hot-Isostatic Pressing

- Hot-isostatic pressing (HIP) combines powder compaction and sintering into a single operation
 - Gas-pressure squeezing at high temperatures
- Heated powders may need to be protected from harmful environments
- Products emerge at full density with uniform, isotropic properties
- Near-net shapes are possible

18.10 Other Techniques to Produce High-Density P/M Products

- High-temperature metal deformation processes can be used to produce high density P/M parts
- Ceracon process- a heated preform is surrounded by hot granular material, transmitting uniform pressure
- Spray forming- inert gases propel molten droplets onto a mold

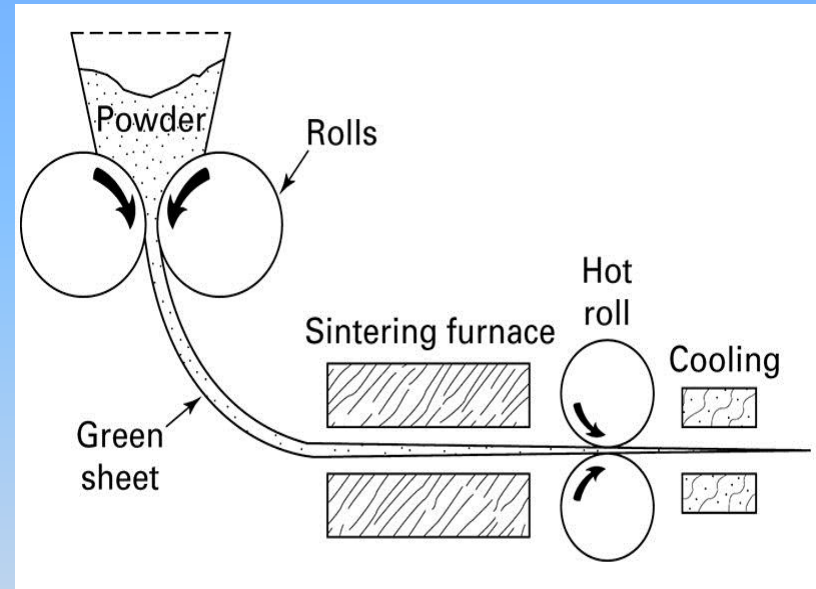

Figure 18-11 One method of producing continuous sheet products from powdered feedstock.

18.11 Metal Injection Molding (MIM) or Powder Injection Molding (PIM)

- Ultra-fine spherical-shaped metal, ceramic, or carbide powders are combined with a thermoplastic or wax
 - Becomes the feedstock for the injection process
- The material is heated to a pastelike consistency and injected into a heated mold cavity
- After cooling and ejection, the binder material is removed
 - Most expensive step in MIM and PIM

MIM

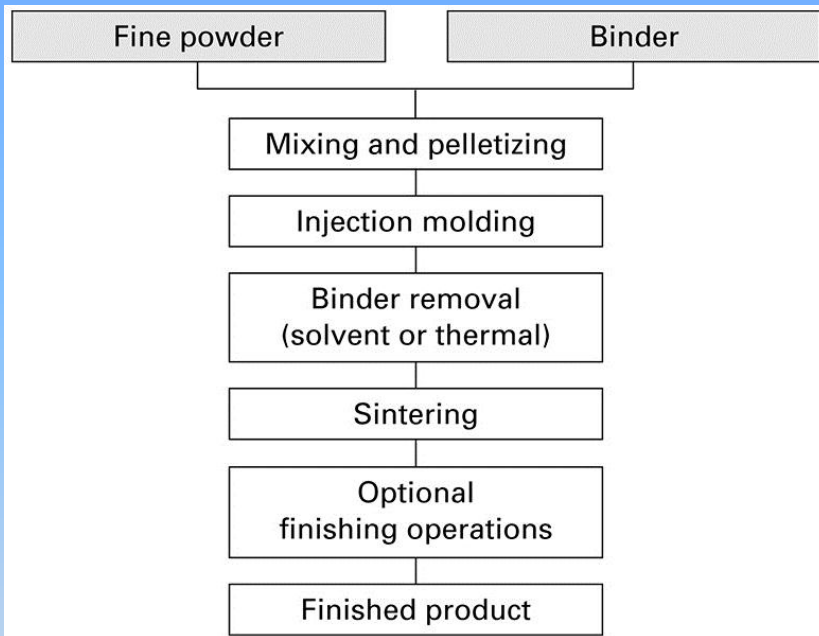

Figure 18-12 Flow chart of the metal injection molding process (MIM) used to produce small, intricate-shaped parts from metal powder.



Figure 18-13 Metal injection molding (MIM) is ideal for producing small, complex parts. (Courtesy of Megamet Solid Metals, Inc., St. Louis, MO.)

18.12 Secondary Operations

- Most powder metallurgy products are ready to use after the sintering process
- Some products may use secondary operation to provide enhanced precision, improved properties, or special characteristics
- Distortion may occur during nonuniform cool-down so the product may be repressed, coined, or sized to improve dimensional precision

Secondary Operations

- If massive metal deformation takes place in the second pressing, the operation is known as P/M forging
 - Increases density and adds precision
- Infiltration and impregnation- oil or other liquid is forced into the porous network to offer lubrication over an extended product lifetime
- Metal infiltration fills in pores with other alloying elements that can improve properties
- P/M products can also be subjected to the conventional finishing operations: heat treatment, machining, and surface treatments

Figure 18-14 (Right) Comparison of conventional forging and the forging of a powder metallurgy preform to produce a gear blank (or gear). Moving left to right, the top sequence shows the sheared stock, upset section, forged blank, and exterior and interior scrap associated with conventional forging. The finished gear is generally machined from the blank with additional generation of scrap. The bottom pieces are the powder metallurgy preform and forged gear produced entirely without scrap by P/M forging. (Courtesy of GKN Sinter Metals, Auburn Hills, MI.)



Figure 18-15 P/M forged connecting rods have been produced by the millions. (Courtesy of Metal Powder Industries Federation, Princeton, NJ.)

18.13 Properties of P/M Products

- The properties of P/M products depend on multiple variables
 - Type and size of powder
 - Amount and type of lubricant
 - Pressing pressure
 - Sintering temperature and time
 - Finishing treatments
- Mechanical properties are dependent on density
- Products should be designed (and materials selected) so that the final properties will be achieved with the anticipated final porosity

P/M Materials

TABLE 18-5 Comparison of Properties of Powder Metallurgy Materials and Equivalent Wrought Metals
(Note how porosity diminishes mechanical performance)

Material ^a	Form and Composition	Condition ^b	Percent of Theoretical Density	Tensile Strength		Elongation in 2 in. (%)
				10 ³ psi	Mpa	
Iron	Wrought	HR	—	48	331	30
	P/M—49% Fe min	As sintered	89	30	207	9
	P/M—99% Fe min	As sintered	94	40	276	15
Steel	Wrought AISI 1025	HR	—	85	586	25
	P/M—0.25% C, 99.75% Fe	As sintered	84	34	234	2
Stainless steel	Wrought type 303	Annealed	—	90	621	50
	P/M type 303	As sintered	82	52	358	2
Aluminum	Wrought 2014	T6	—	70	483	20
	P/M 201 AB	T6	94	48	331	2
	Wrought 6061	T6	—	45	310	15
	P/M 601 AB	T6	94	36.5	252	2
Copper	Wrought OFHC	Annealed	—	34	234	50
	P/M copper	As sintered	89	23	159	8
		Repressed	96	35	241	18
Brass	Wrought 260	Annealed	—	44	303	65
	P/M 70% Cu-30% Zn	As sintered	89	37	255	26

^aEquivalent wrought metal shown for comparison. ^bHR, hot rolled; T6, age hardened.

18.14 Design of Powder Metallurgy Parts

- Basic rules for the design of P/M parts
 - Shape of the part must permit ejection from die
 - Powder should not be required to flow into small cavities
 - The shape of the part should permit the construction of strong tooling
 - The thickness of the part should be within the range for which P/M parts can be adequately compacted
 - The part should be designed with as few changes in section thickness as possible

Basic Rules for P/M Parts

- Parts can be designed to take advantage of the fact that certain forms and properties can be produced by P/M that are impossible, impractical, or uneconomical by any other method
- The design should be consistent with available equipment
- Consideration should be made for product tolerances
- Design should consider and compensate for dimensional changes that will occur after pressing

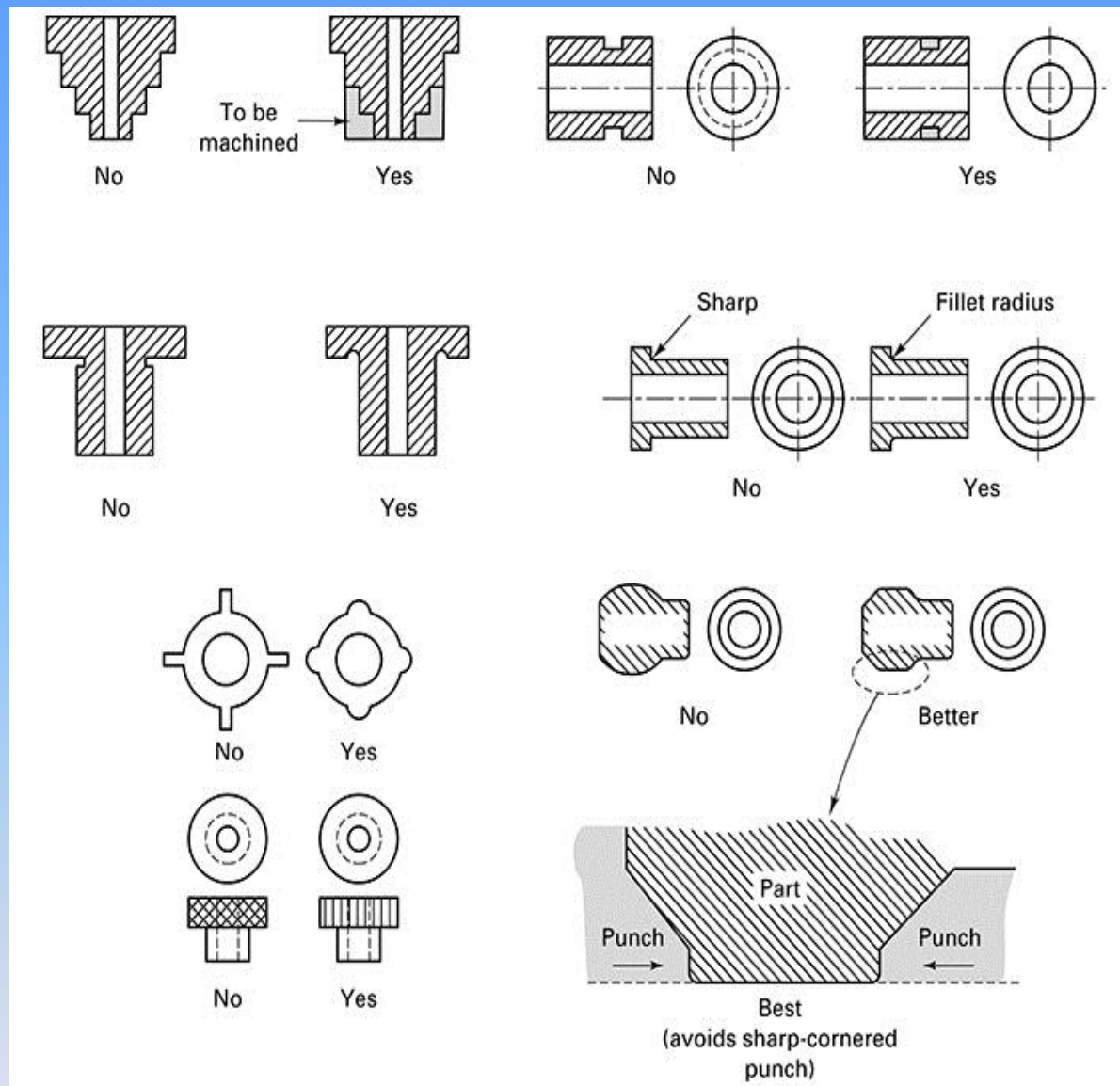

Figure 18-17 Examples of poor and good design features for powder metallurgy products. Recommendations are based on ease of pressing, design of tooling, uniformity of properties, and ultimate performance.

18.15 Powder Metallurgy

Products

- Porous or permeable products such as bearings, filters, and pressure or flow regulators
- Products of complex shapes that would require considerable machining when made by other processes
- Products made from materials that are difficult to machine or materials with high melting points
- Products where the combined properties of two or more metals are desired
- Products where the P/M process produces clearly superior properties
- Products where the P/M process offers an economic advantage

18.16 Advantages and Disadvantages of Powder Metallurgy

- Advantages
 - Elimination or reduction of machining
 - High production rates
 - Complex shapes
 - Wide variations in compositions
 - Wide property variations
 - Scrap is eliminated or reduced
- Disadvantages
 - Inferior strength properties
 - High tooling costs
 - High material cost
 - Size and shape limitations
 - Dimensional changes during sintering
 - Density variations
 - Health and safety hazards

TABLE 18-6 Comparison of Four Powder Processing Methods

Characteristic	Conventional Press and Sinter	Metal Injection Molding (MIM)	Hot-Isostatic Pressing (HIP)	P/M Forging
Size of workpiece	Intermediate <5 pounds	Smallest <1/4 pounds	Largest 1-1000 pounds	Intermediate <5 pounds
Shape complexity	Good	Excellent	Very good	Good
Production rate	Excellent	Good	Poor	Excellent
Production quantity	>5000	>5000	1-1000	>10,000
Dimensional precision	Excellent ± 0.001 in./in.	Good ± 0.003 in./in.	Poor ± 0.020 in./in.	Very good ± 0.0015 in./in.
Density	Fair	Very good	Excellent	Excellent
Mechanical properties	80-90% of wrought	90-95% of wrought	Greater than wrought	Equal to wrought
Cost	Low \$0.50-5.00/lb	Intermediate \$1.00-10.00/lb	High >\$100.00/lb	Somewhat low \$1.00-5.00/lb

18.17 Summary

- Powder metallurgy can produce products out of materials that are otherwise very difficult to manufacture
- P/M products can be designed to provide the targeted properties
- Variations in product size, production rate, quantity, mechanical properties, and cost