

Turning and Boring Processes

Chapter 22

22.1 Introduction

- Turning is the process of machining external cylindrical and conical surfaces.
- Boring is a variant of turning where the machining results in an internal cylindrical or conical surface.
- Turning and Boring are performed on a lathe where a single point tool is moved across the rotating workpiece

Standard Engine Lathe

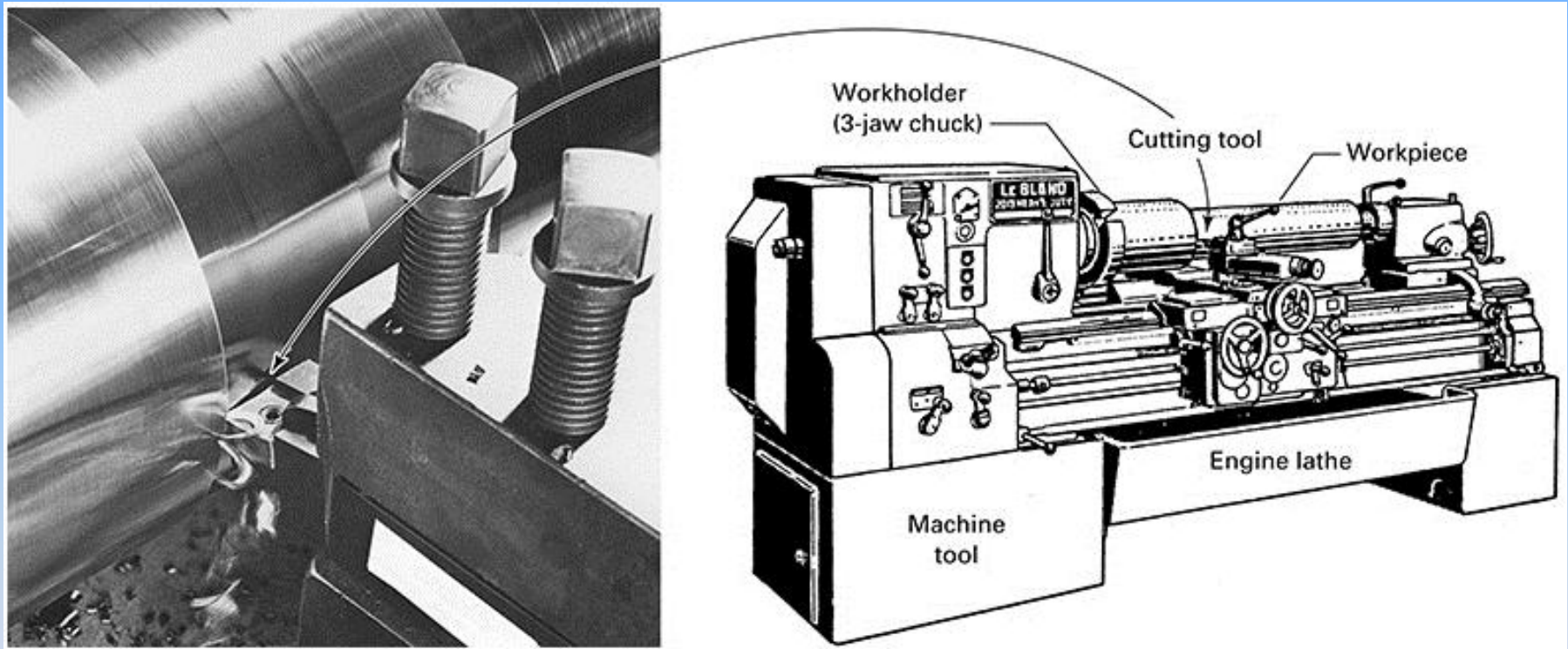

FIGURE 22-1 Schematic of a standard engine lathe performing a turning operation, with the cutting tool shown in inset.

Basic Turning Operations

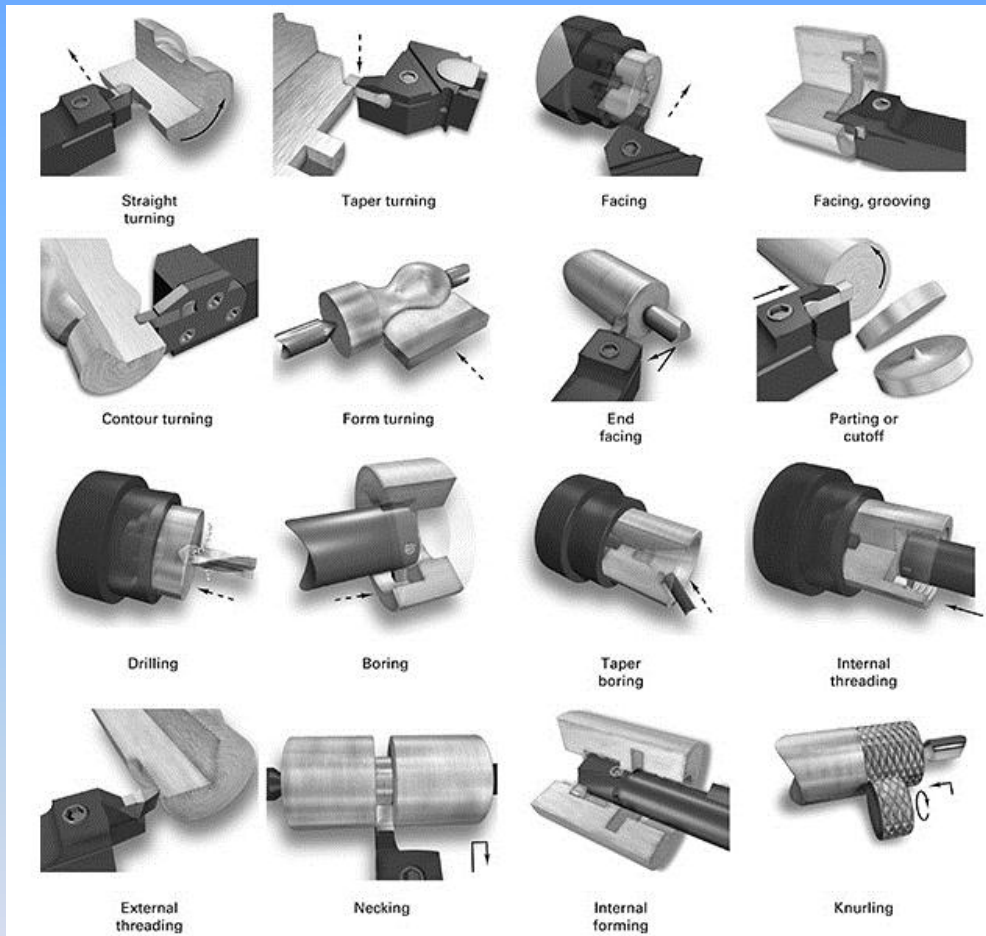

FIGURE 22-2 Basic turning machines can rotate the work and feed the tool longitudinally for turning and can perform other operations by feeding transversely. Depending on what direction the tool is fed and on what portion of the rotating workpiece is being machined, the operations have different names. The dashed arrows indicate the tool feed motion relative to the workpiece.

22.2 Fundamentals of Turning, Boring, and Facing Operations

- Turning constitutes the majoring of lathe work and is summarized in two categories.
 - Roughing: Used to remove large amounts of material using large depth of cuts and slow speeds. Requires less time to remove material, though dimensional accuracy and surface finish quality are lost.
 - Finishing: Uses light passes with speeds as fine as necessary to produce the desired finish. One to two passes are usually required to produce a smooth finish.

Turning Calculations

FIGURE 22-3 Basics of the turning process normally done on a lathe. The dashed arrows indicate the feed motion of the tool relative to the work.

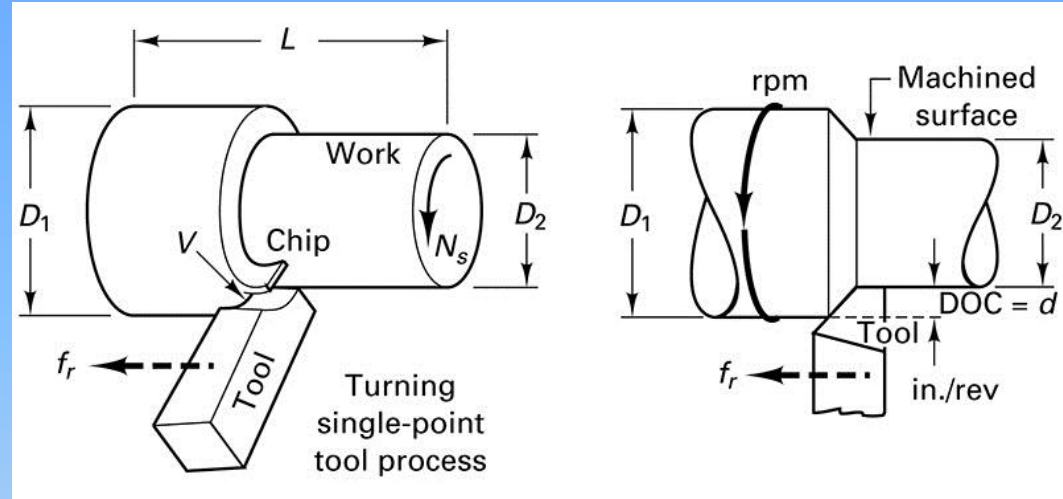

Depth of Cut

$$d = \text{DOC} = \frac{D_1 - D_2}{2} \text{ inches}$$

Lathe rpm

$$\frac{N_s = 12V}{\pi D_1}$$

Cutting Time

$$\frac{T_m = L + A}{f_r N_s}$$

Turning Calculations, cont.

FIGURE 22-3 Basics of the turning process normally done on a lathe. The dashed arrows indicate the feed motion of the tool relative to the work.

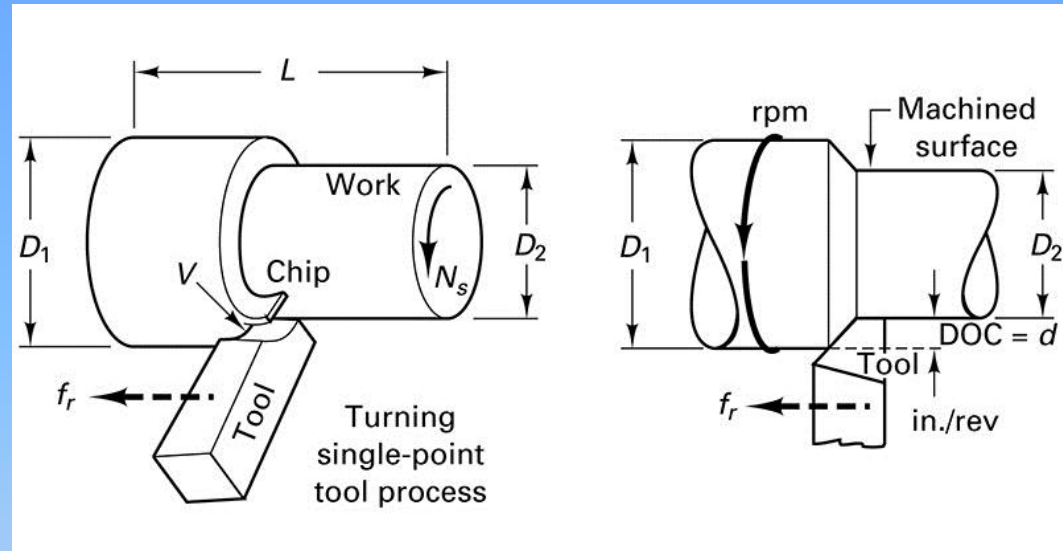

Metal Removal Rate, MRR

$$\text{MRR} = \frac{\text{volume removed}}{\text{time}} = \frac{(\pi D_1^2 - \pi D_2^2)L}{4L/f_r N}$$

Alternate equation for MRR

$$\text{MRR} \cong 12 V f_r d \text{ in.}^3/\text{min}$$

Boring Calculations

FIGURE 22-4 Basic movement of boring, facing, and cutoff (or parting) process.

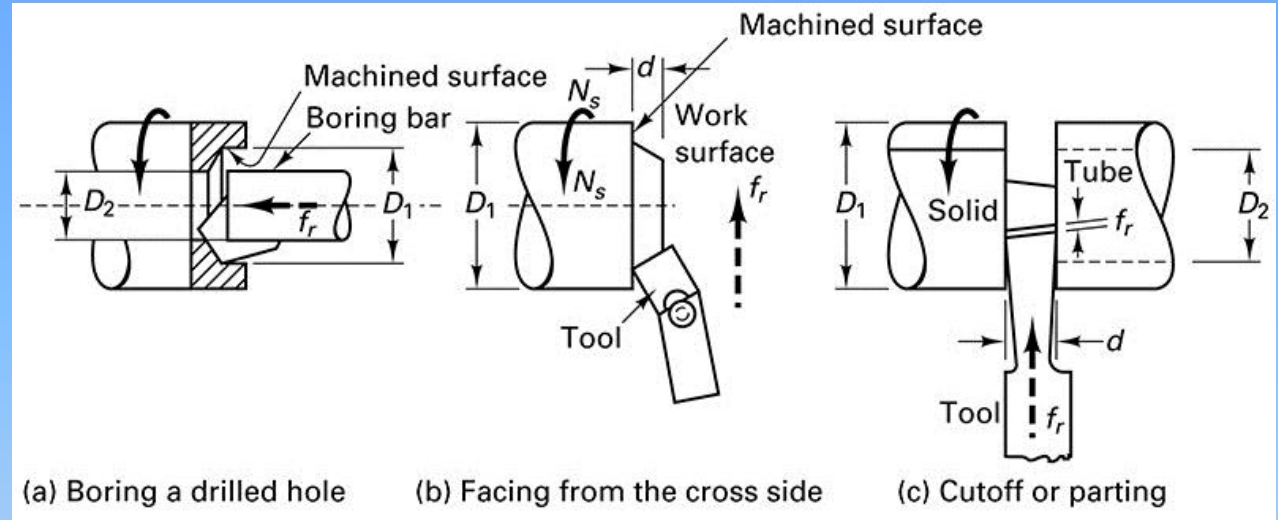

- Cutting time

$$T_m = \frac{L + A}{f_r N_s}$$

- Material Removal Rate

$$\frac{\text{MRR} = L(\pi D_1^2 - \pi D_2^2)/4}{L/f_r N}$$

$$\text{MRR} \cong 12 V f_r d$$

or

Facing Calculations

FIGURE 22-4 Basic movement of boring, facing, and cutoff (or parting) process.

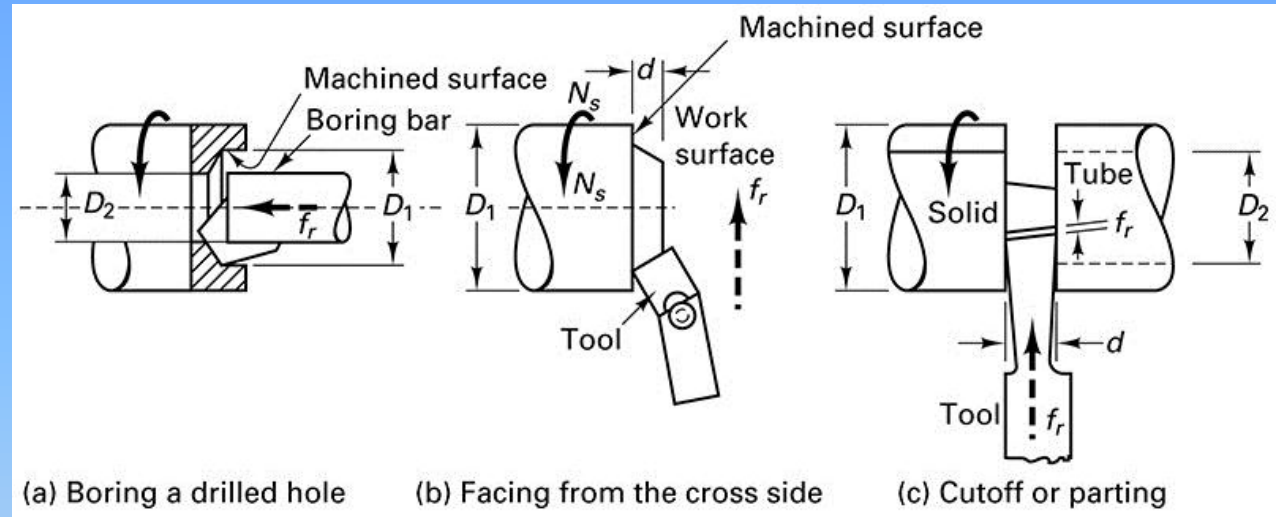

- Cutting time

$$T_m = \text{cutting time} = \frac{L + A}{f_n N} \text{ minutes} = \frac{\frac{D_1}{2} + A}{f_n N}$$

- Material Removal Rate

$$\text{MRR} = \frac{\text{VOL}}{T_m} = \frac{\pi D_1^2 d f_r N}{4L} = 6V f_r d \text{ in.}^3/\text{min}$$

Deflection in Boring, Facing, and Cutoff Operations

- The speed, feed and depth of cut are less in Boring, Facing and Cutoff operations because of the large overhang of the tools. Basic deflection calculations for the tool are:

$$\delta = \frac{Pl^3}{3EI} = \frac{F_c l^3}{3EI}$$

E = modulus of elasticity

I = moment of inertia of cross section of tool

$P = F_c$ = applied load or cutting force

$I = \pi D_1^4/64$ solid round bar

$I = \pi(D_1^4 - (D_2^4))/64$ bar with hole

D_1 = diameter of tube or bar

D_2 = inside diameter of the tube

Other Lathe Operations

- Precision Boring: Bored holes often are bell mouthed due to tool deflection. To compensate a pilot bushing is used within the chuck as shown:

FIGURE 22-5 Pilot boring bar mounted in tailstock of lathe for precision boring large hole in casting. The size of the hole is controlled by the rotation diameter of the cutting tool.

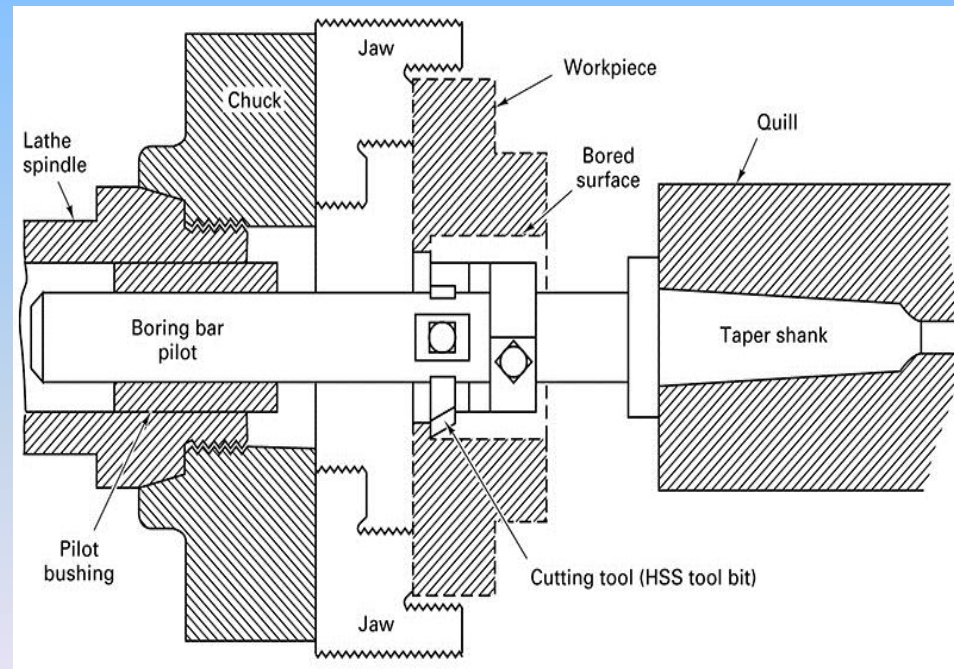

Dimensional Accuracy in Turning

FIGURE 22-7 Accuracy and precision in turning is a function of many factors, including tool wear and BUE.

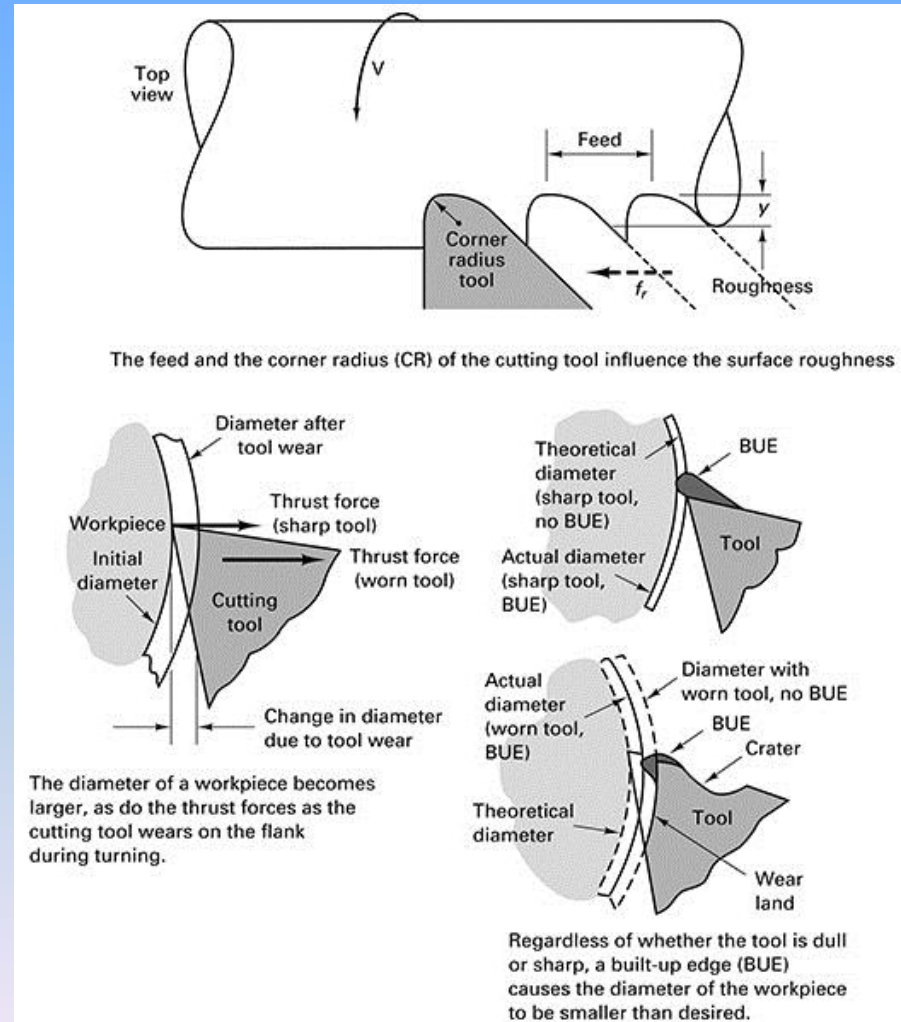

22.3 Lathe Design and Terminology

- Lathe Engine essential components:
 - Bed
 - Gray cast for vibration dampening
 - Headstock assembly
 - Spindle
 - Transmission
 - Drive motor
 - Tailstock assembly
 - Longitudinal way clamp
 - Transverse way clamp
 - Quill for cutting tools, live centers, or dead centers

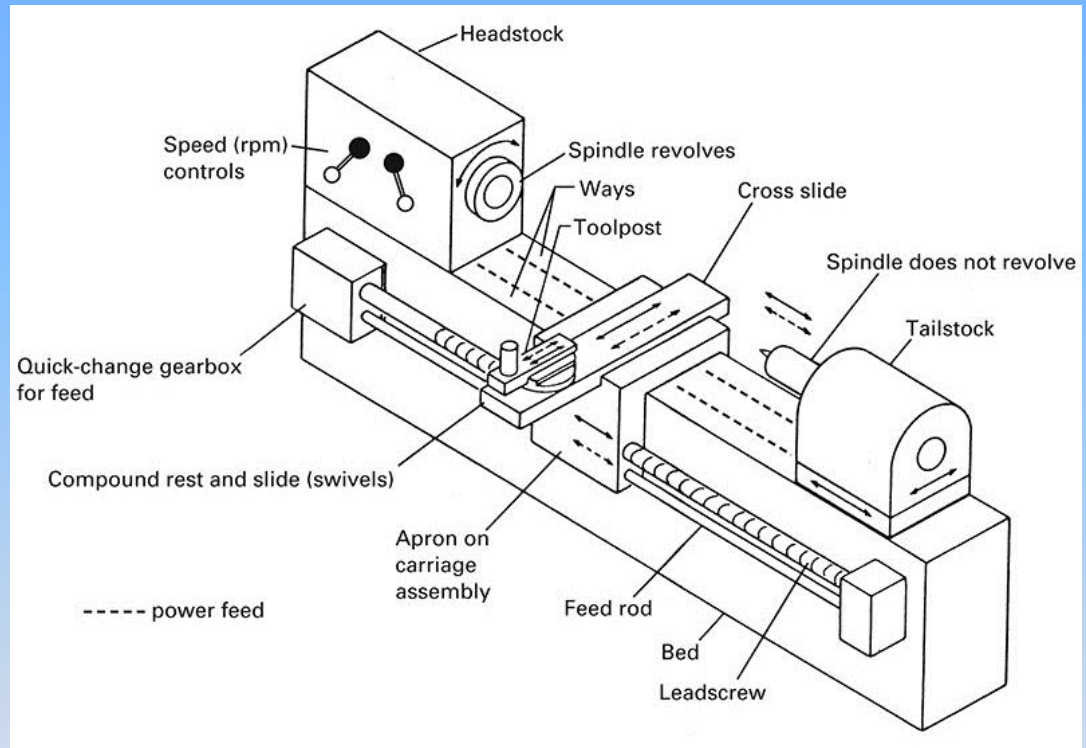

FIGURE 22-8 Schematic diagram of an engine lathe, showing basic components.

22.3 Lathe Design and Terminology

- Lathe Engine essential components:
 - Quick-change gearbox
 - Powers Carriage Assembly movement with lead screw
 - Carriage Assembly
 - Fixed to cross slide
 - Holds tool post at variable orientations
 - Provides longitudinal and transverse movement of tooling
 - Ways
 - Provides precise guidance to carriage assembly and tailstock

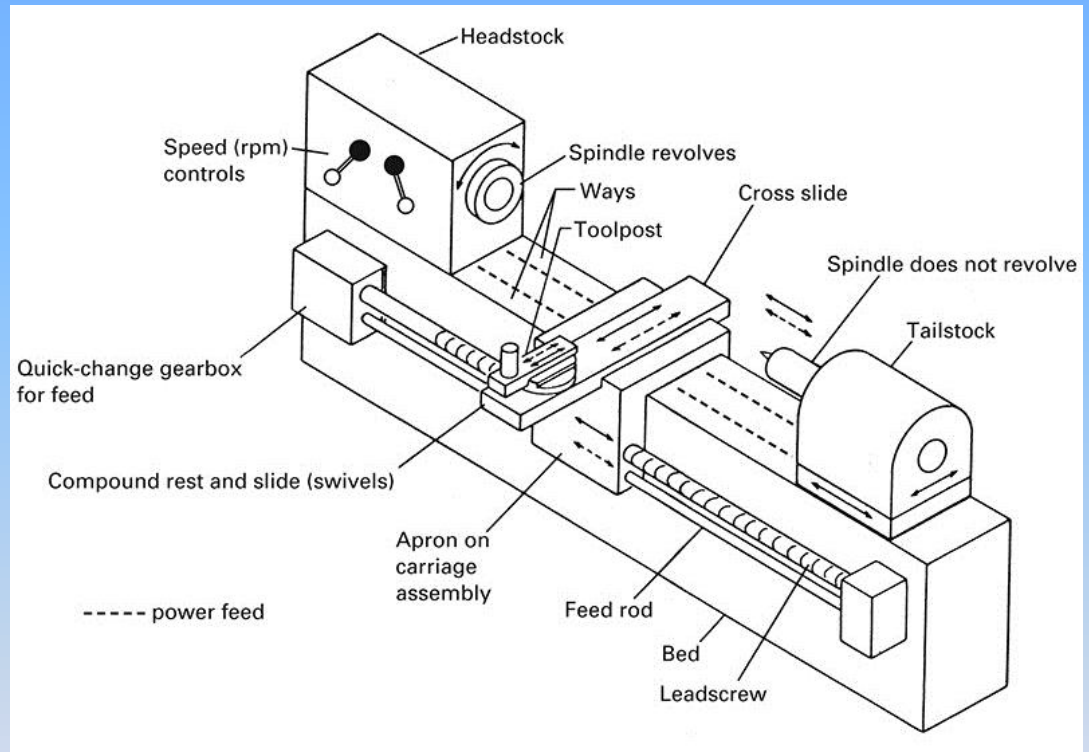

FIGURE 22-8 Schematic diagram of an engine lathe, showing basic components.

Types of Lathes

- Speed Lathes
 - Limited to headstock, tailstock, and simple tool post.
 - Limited to 3-4 speeds
 - High spindle speeds,
 - For light work such as wood turning, metal polishing, or metal spinning
- Engine Lathes
 - Most common type
 - Variable in design from low to high power designs
 - Broad range of lengths up to 60ft long
 - Features as described in Figure 22.8

Types of Lathes, cont.

- Toolroom Lathes
 - Specialized Engine lathe with greater accuracy.
 - Broader range of speeds and feeds
 - Greater versatility for tool and die manufacturing
- Turret Lathes
 - Turret on tool post rotates to position a variety of tools
 - Capstan wheel used to pull to away from work piece to position next tool
 - A number of tools set up on machine, each brought up in quick succession to complete the part in a single setup

Types of Lathes, Turret Lathes

- **FIGURE 22-12**
Block diagrams of
ram- and saddle-
turret lathe.

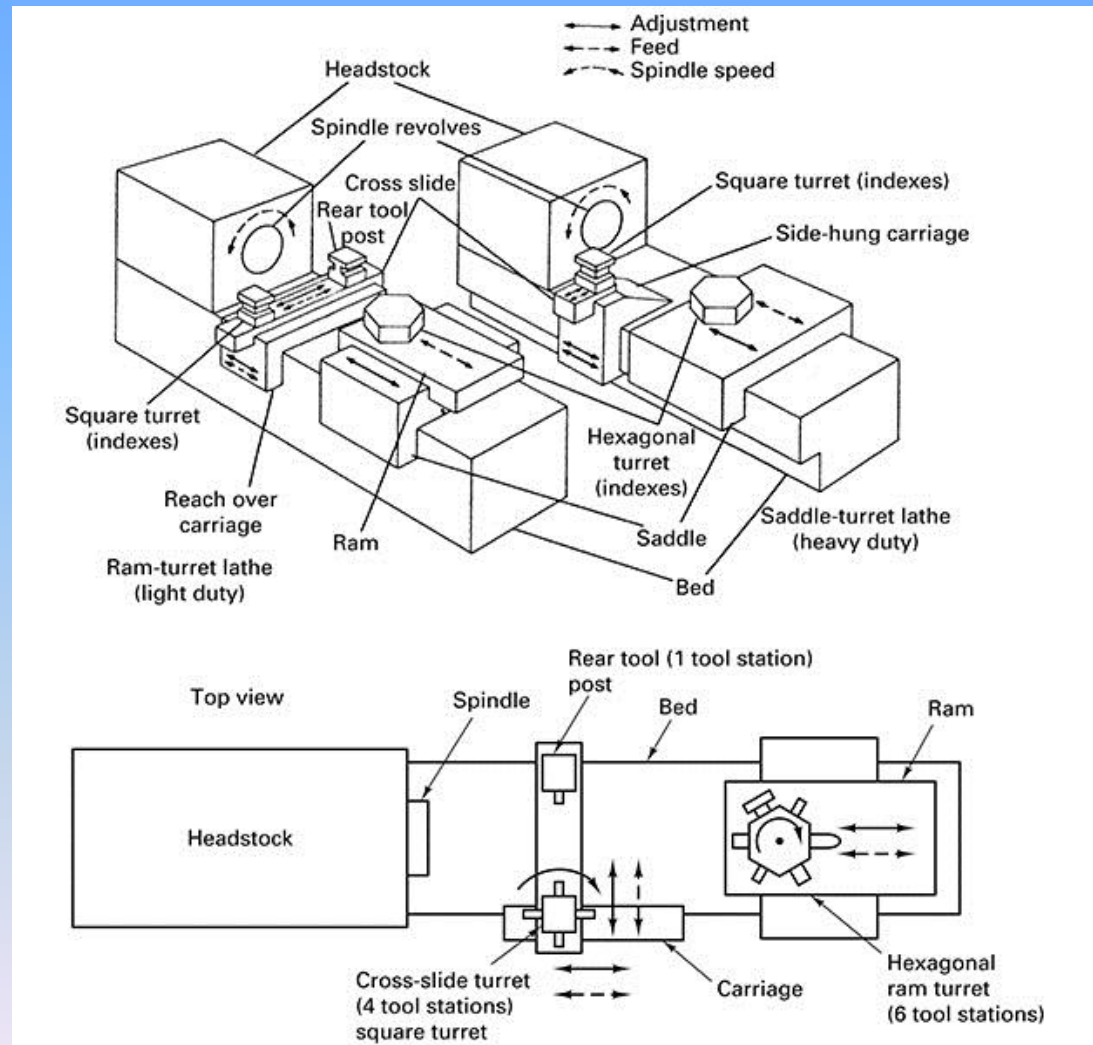

Types of Lathes

- Automatic Lathes
 - Also called Swiss Screw machine
 - A specialized type of automatic turret lathe
 - Rod stock is automatically fed into the collet

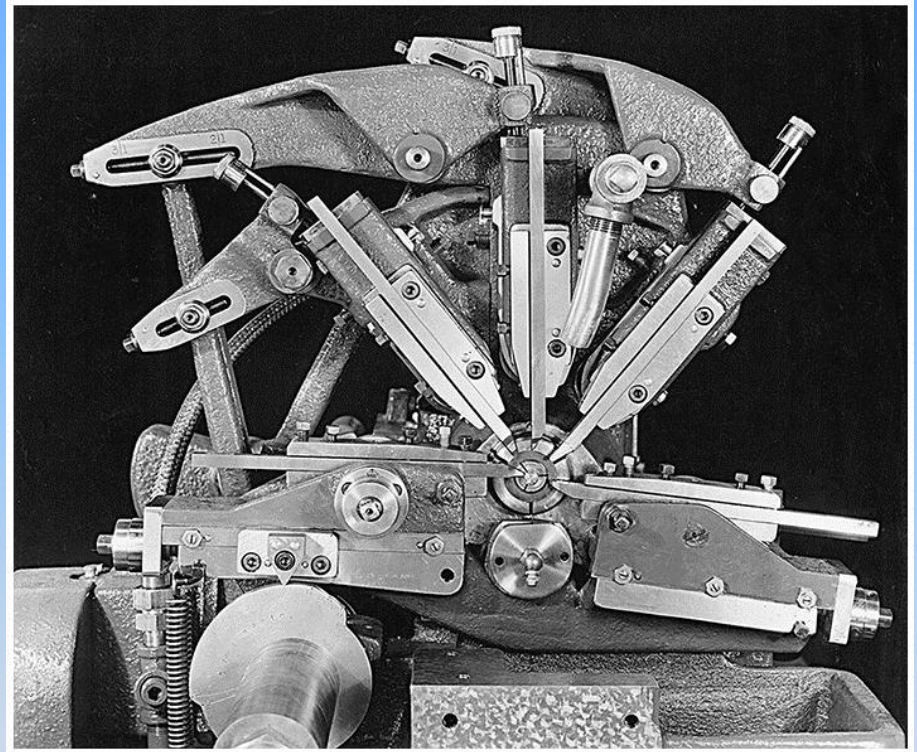

22.4 Cutting Tools for Lathes

- Tools consists of cutting surface and support
 - Cutting surfaces can be of same material as support or a separate insert
 - Supports materials must be rigid and strong enough to prevent tool deflection during cutting
 - Cutting materials are typically carbides, carbide coatings, ceramics, or high carbon steels
 - Inserts are used to decrease cost in that the insert is disposed of, and the support reused.

Typical Tool Holders

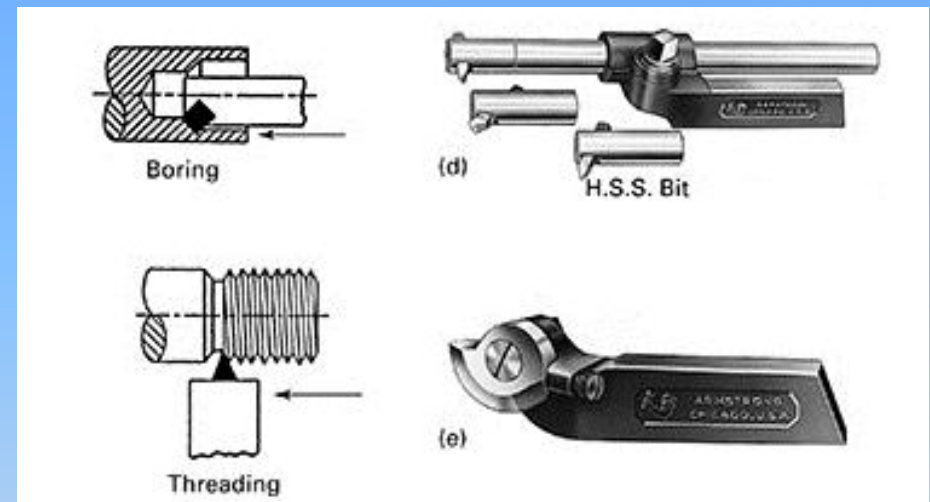
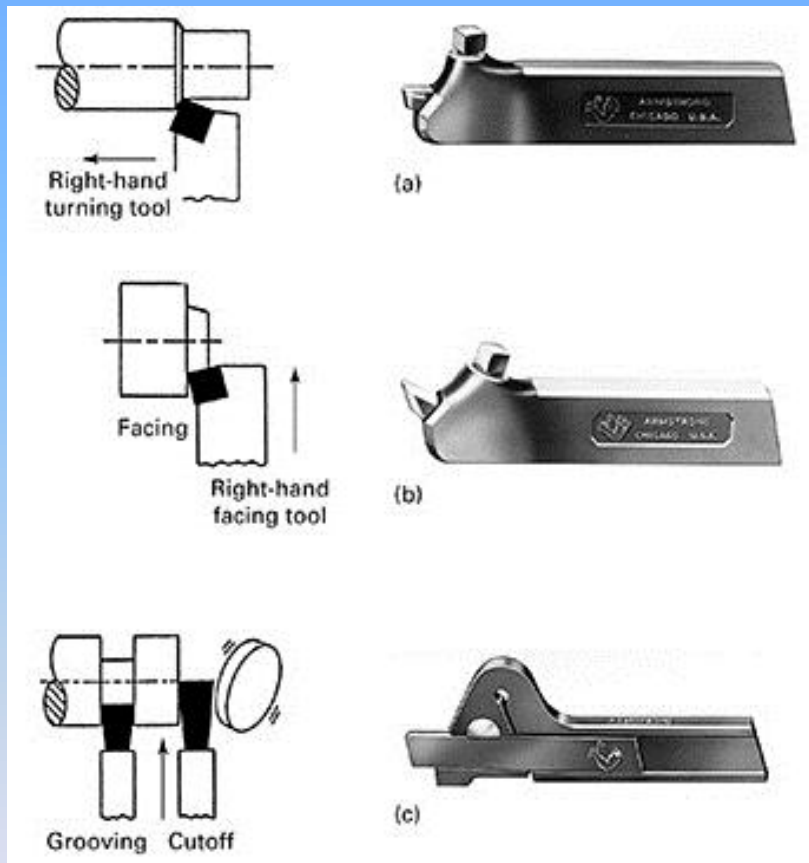
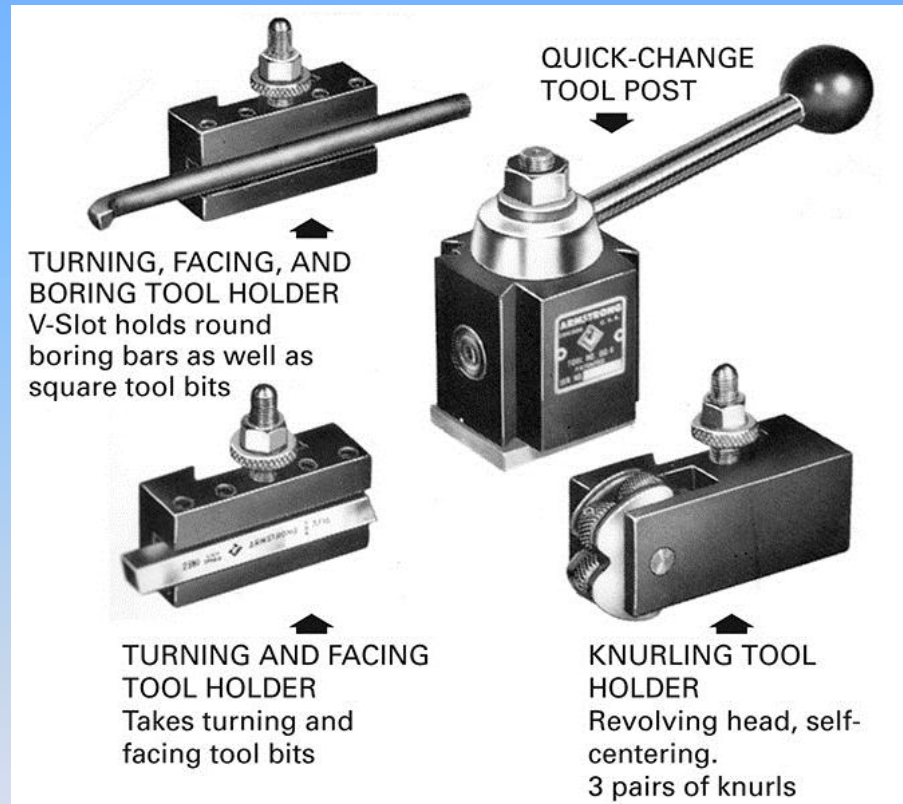

FIGURE 22-16 Common types of forged tool holders: (a) right-hand turning, (b) facing, (c) grooving cutoff, (d) boring, (e) threading. (Courtesy of Armstrong Brothers Tool Company.)

Quick Change Tool Holders

- Tool changing can take over 50% of manual lathe operations
- Quick Change holders are used to reduce manual tool change time and increase production



22.5 Workholding Devices for Lathes

- Work pieces can be held by various methods
 - Work piece mounted between centers
 - Work piece mounted within a single chuck
 - Work piece mounted within a collet
 - Work piece mounted on a faceplate

Lathe Centers

- A lathe center hold the end of the work piece, providing support to preventing the work piece from deflecting during machining
- Lather centers can be mounted in the spindle hole, or in the tailstock quill
- Lathe centers fall into two categories
 - Dead Center: solid steel tip that work piece spins against
 - Live Center: centers contact point is mounted on bearings and allowed to spin with work piece

Lathe Centers

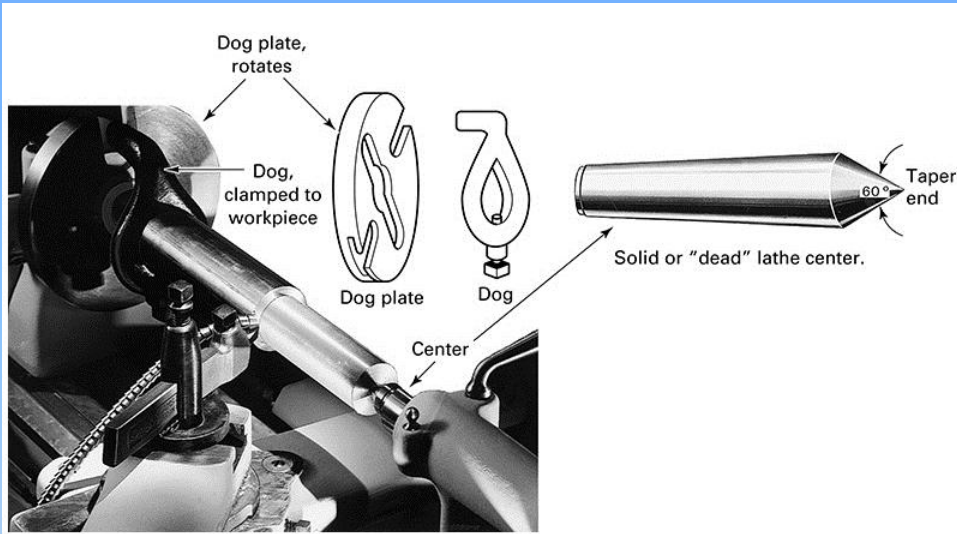

FIGURE 22-21 Work being turned between centers in a lathe, showing the use of a dog and dog plate. (Courtesy of South Bend Lathe.)

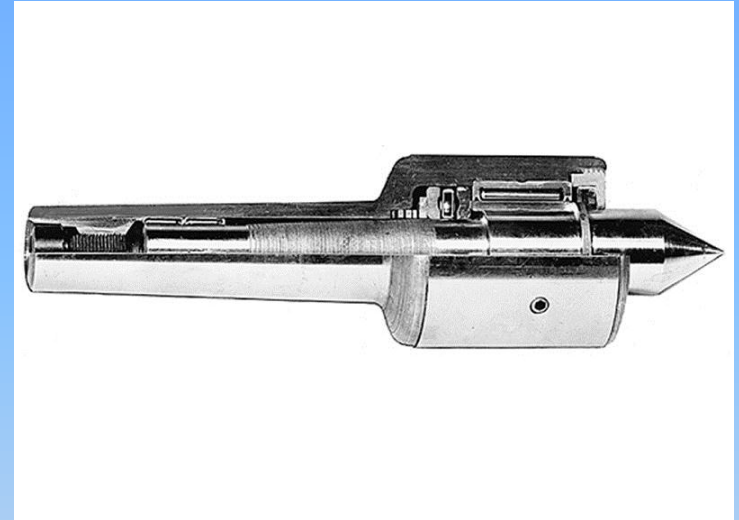

FIGURE 22-22 Live lathe center can rotate with the part.

Lathe Chucks

- Lathe Chucks are adjustable mechanical vises that hold the work piece and transfer rotation motion from the drive motor to the work piece
- Lathe Chucks come in two basic types
 - Three-jaw self-centering chucks
 - Used to center round or hexagonal stock
 - Four-jaw independent chucks
 - Each jaw moves independently to accommodate various work piece shapes

Lathe Chucks

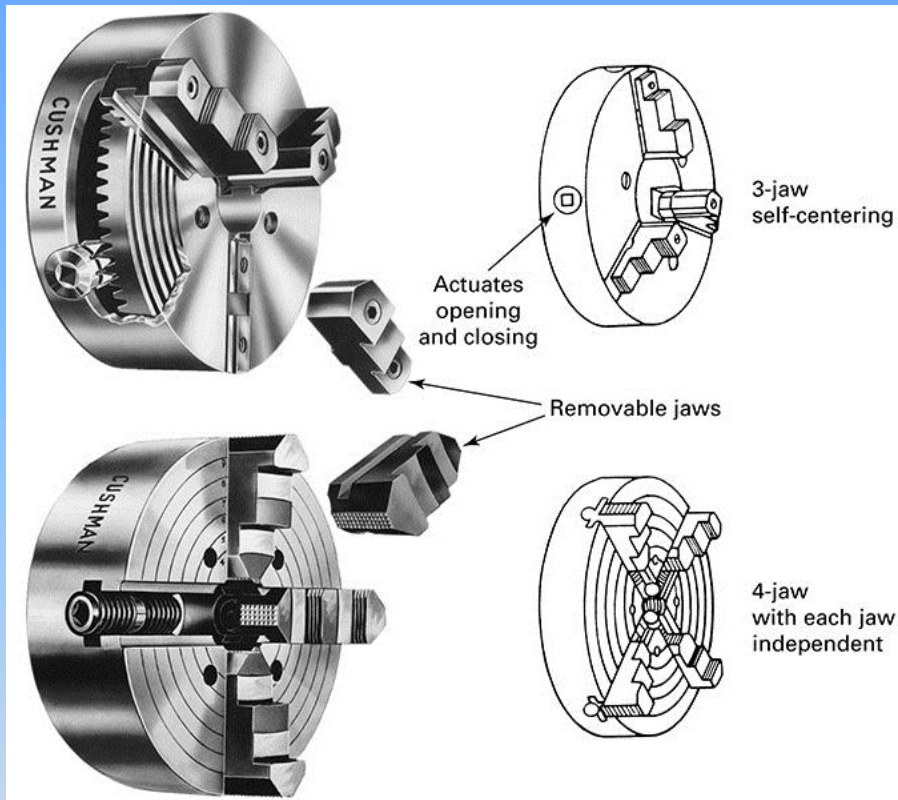

FIGURE 22-24 The jaws on chucks for lathes (four-jaw independent or three-jaw self-centering) can be removed and reversed.

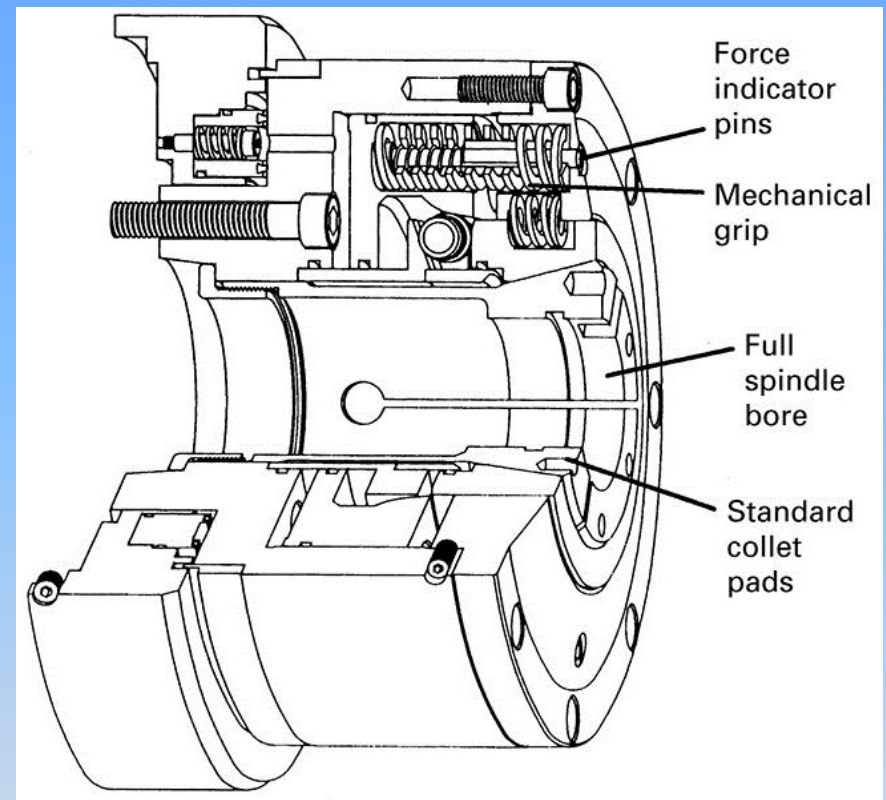

FIGURE 22-25 Hydraulically actuated through-hole three-jaw power chuck shown in section view to left and in the spindle of the lathe above connected to the actuator.

Lathe Collets

- Collets are used to hold round stock of standard sizes
- Most accurate holding method for round stock
 - Run out less than 0.0005 inch
 - Stock should be no more than 0.002 inch larger or 0.005 smaller than the collet
 - Typically used for drill-rod, cold-rolled, extruded, or previously machined stock

Lathe Collets



FIGURE 22-26 Several types of lathe collets. (Courtesy of South Bend Lathe.)

Face Plates

- Face plates are used to mount irregular work pieces that can not be gripped with a chuck
- Face plates are typically custom built to each work piece
- The face plate is mounted to a center, or mounted in a chuck

Summary

- Lathes are used for turning, boring, drilling and facing
- Lathe typically holds the work piece in a rotating chuck, with the opposite end supported by a center held in the tailstock
- A wide variety of lathe types, and tool types are available depending upon the application and the rate of production