

Drilling and Related Hole-Making Processes

Chapter 23

23.1 Introduction

- Drilling is most common single machining operation
- Drilling makes up 25% of machining
- Drilling occurs at the end of a tool within the material, four actions take place at the drill tip
 - **1.** A small hole is formed by the web—chips are not cut here in the normal sense.
 - **2.** Chips are formed by the rotating lips.
 - **3.** Chips are removed from the hole by the screw action of the helical flutes.
 - **4.** The drill is guided by lands or margins that rub against the walls of the hole

Nomenclature and Geometry of a Drill

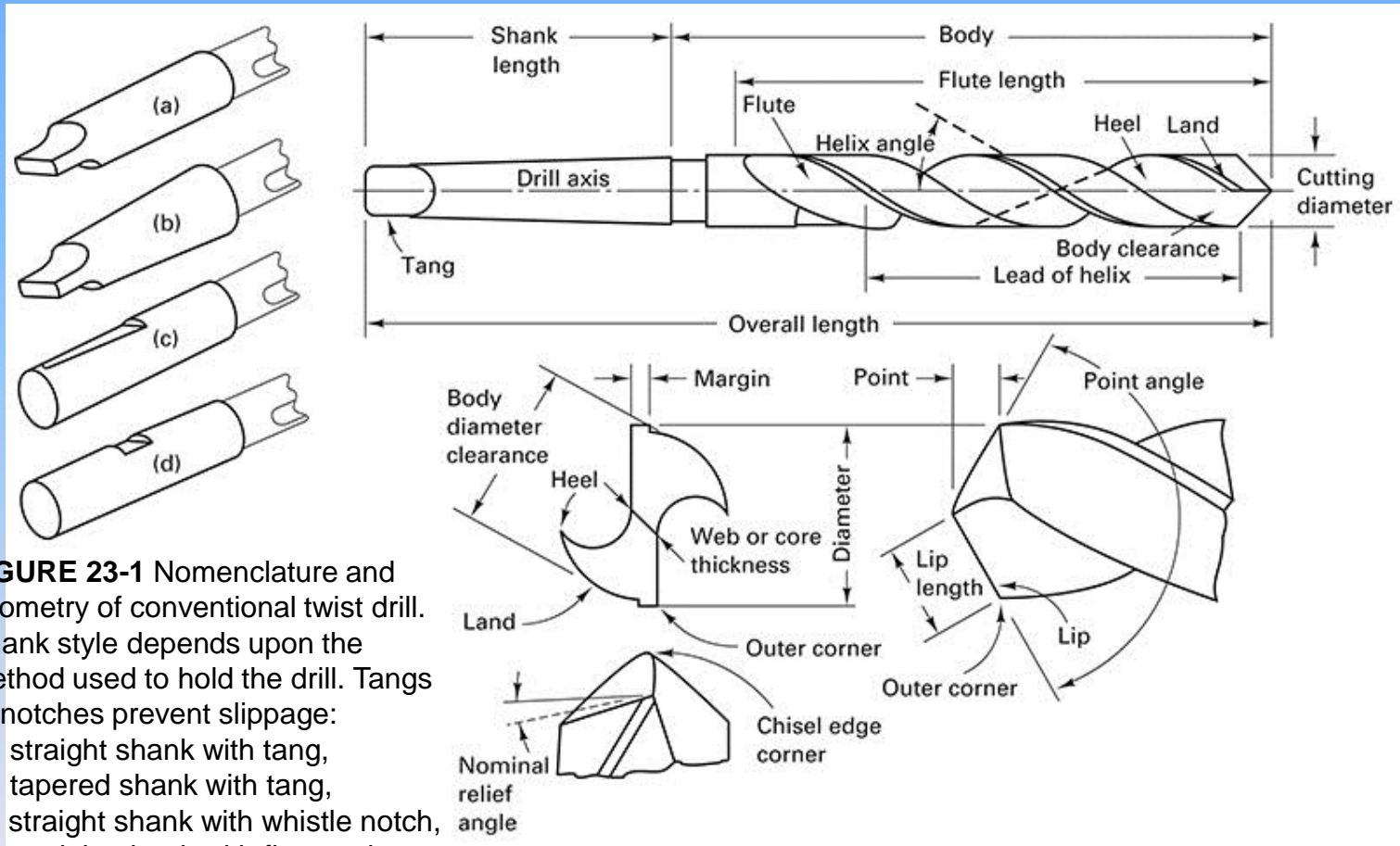

FIGURE 23-1 Nomenclature and geometry of conventional twist drill. Shank style depends upon the method used to hold the drill. Tangs or notches prevent slippage:
 (a) straight shank with tang,
 (b) tapered shank with tang,
 (c) straight shank with whistle notch,
 (d) straight shank with flat notch.

23.2 Fundamentals of the Drilling Process

- A conventional two-flute drill, with drill of diameter D , has two principal cutting edges rotating at an rpm rate of N and feeding axially.
- The rpm of the drill is established by the selected cutting velocity or cutting speed with V in surface feet per minute and D in inches.

$$N_s = \frac{12V}{\pi D}$$

Conventional Drill Geometry

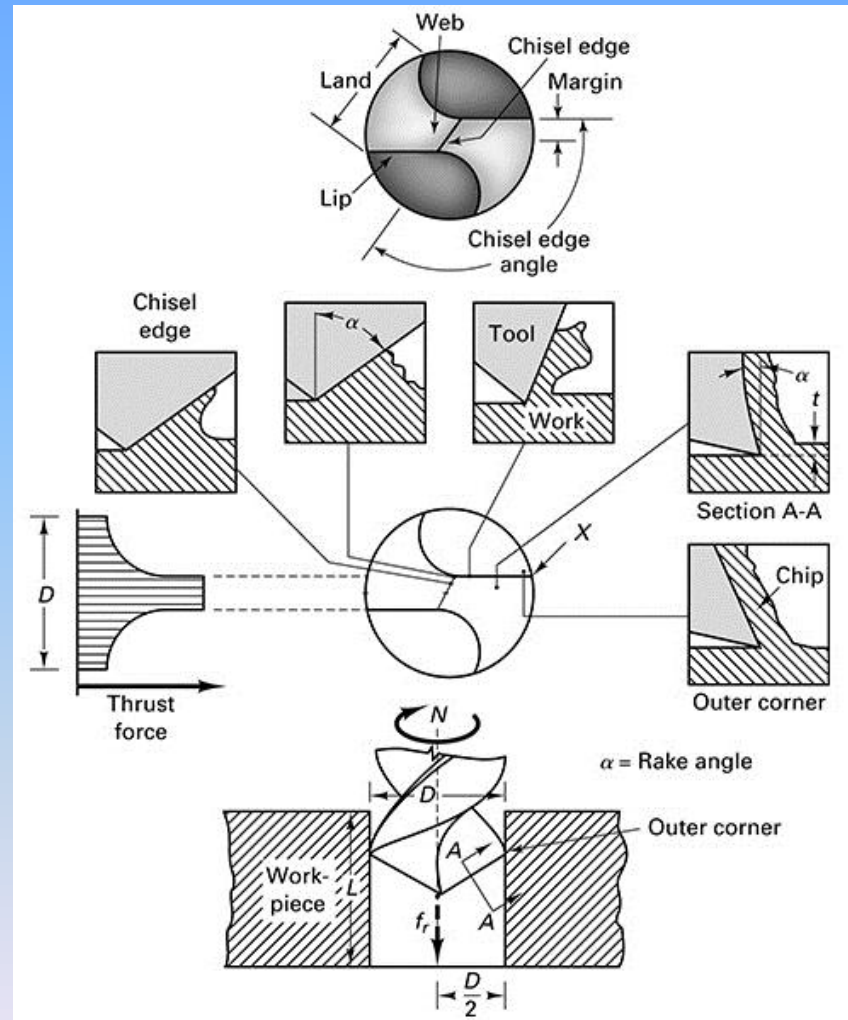

FIGURE 23-2 Conventional drill geometry viewed from the point showing how the rake angle varies from the chisel edge to the outer corner along the lip. The thrust force increases as the web is approached.

Material Removal Rate

- The material removal rate (MRR) for drilling is:

$$\begin{aligned} \text{MRR} &= \frac{\text{volume}}{T_m} \\ &= \frac{\pi D^2 L / 4}{L / f_r N_s} \text{ (omitting allowances)} \end{aligned}$$

- Which reduces to

$$\text{MRR} = (\pi D^2 / 4) f_r N_s \text{ in.}^3 \quad \text{or} \quad \text{MRR} \cong 3DV f_r$$

Were T_m is cutting time, f_r is feed rate, and L is depth of the hole.

23.3 Types of Drills

- The most common drills are twist drills
- Twist drills have three parts
 - The body: consisting of spiral grooves called flutes, separated by lands
 - The point: a wide variety of geometry are used, but typically have a cone angle of 118° , and a rake angle of 24°
 - The shank: a straight or tapered section where the drill is clamped.

Types of Twist Drills

FIGURE 23-3 Types of twist drills and shanks. Bottom to top: Straight-shank, three-flute core drill; straight-shank; taper-shank; bit-shank; straight-shank, high-helix angle; straight-shank, straight-flute; taper-shank, subland drill.



Drill Walking

- Standard drills have a straight line chisel point.
- This point caused drills to “walk” along the surface
- This effect is counter by using centering techniques
 - Center punches
 - Pre-drilled guide holes for large holes
- Specialized methods of grinding the point address walking

Specialized Tips

- Specialized tips are used to produce self centering holes where hole position is critical.
 - Helical tips
 - Four-facet tips
 - Racon
 - Bickford
 - Center core, or slot drills
- Used in machining centers and high speed automatic NC systems where manual center punching is impractical

Drill Point Geometry

FIGURE 23-4 As the drill advances, it produces a thrust force. Variations in the drill-point geometry are aimed at reducing the thrust force.

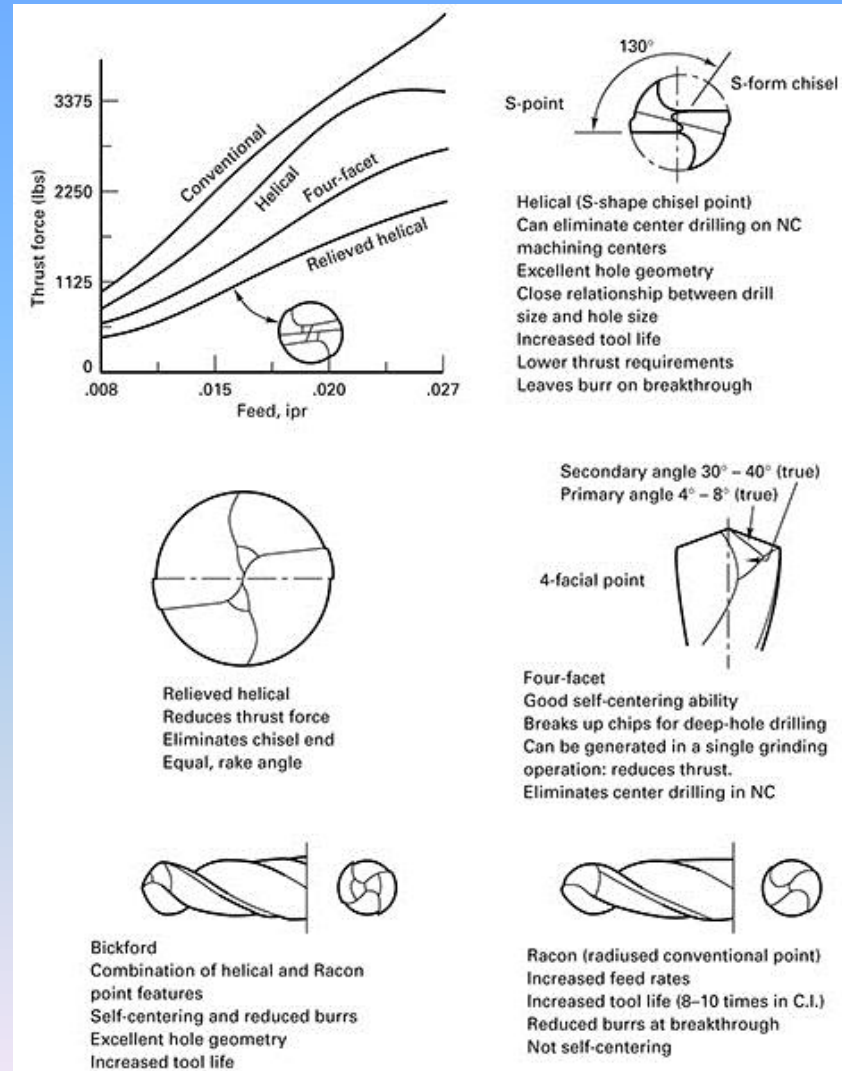

Center Core Drill

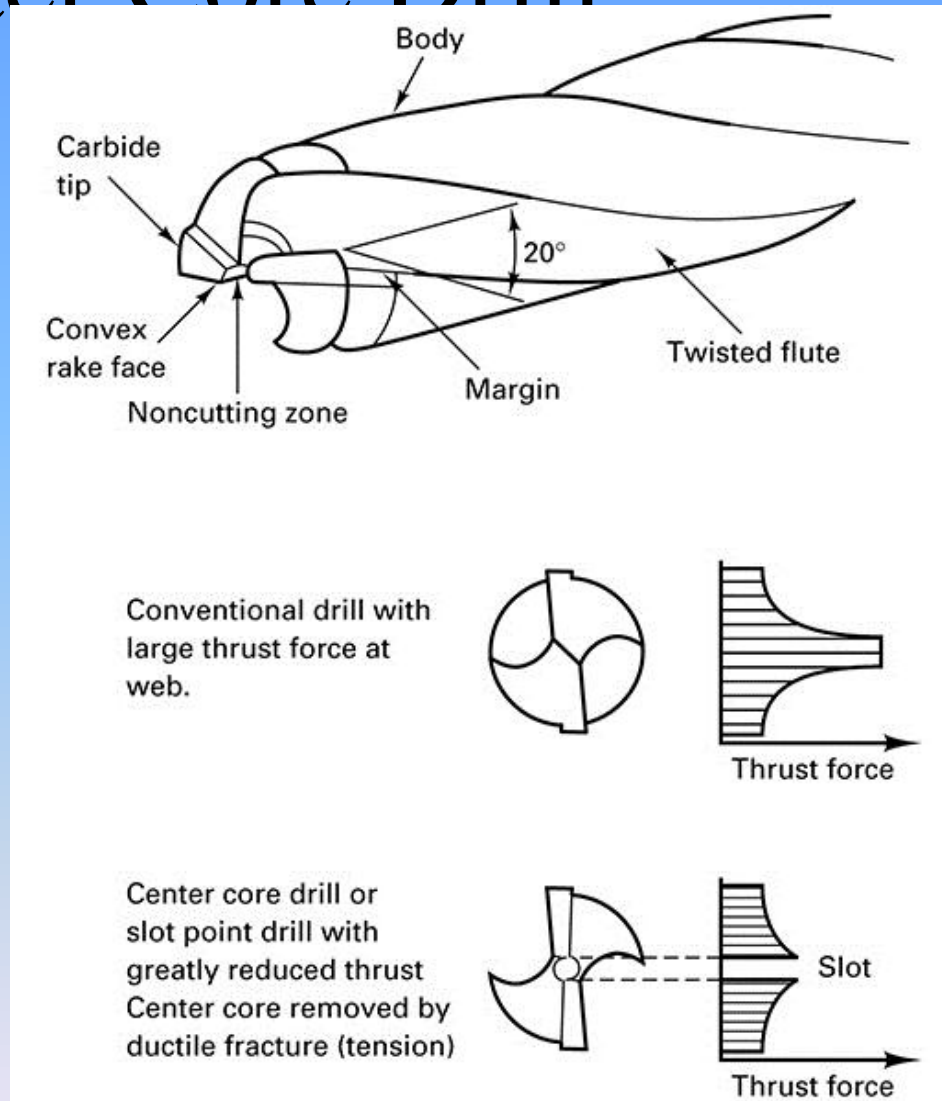
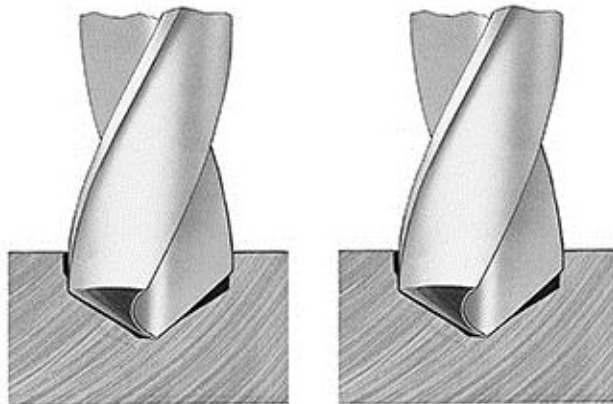

FIGURE 23-5 Center core drills can greatly reduce the thrust force.

Typical Causes of Drilling Problems



(a) Angle unequal

(b) Length unequal

Outer corners break down: Cutting speed too high; hard spots in material; no cutting compound at drill point; flutes clogged with chips

Cutting lips chip: Too much feed; lip relief too great

Checks or cracks in cutting lips: Overheated or too quickly cooled while sharpening or drilling

Chipped margin: Oversize jig bushing

Drill breaks: Point improperly ground; feed too heavy; spring or backlash in drill press, fixture, or work; drill is dull; flutes clogged with chips

Tang breaks: Imperfect fit between taper shank and socket caused by dirt or chips or by burred or badly worn sockets

Drill breaks when drilling brass or wood: Wrong type drill; flutes clogged with chips

Drill spits up center: Lip relief too small; too much feed

Drill will not enter work: Drill is dull; web too heavy; lip relief too small

Hole rough: Point improperly ground or dull; no cutting compounds at drill point; improper cutting compound; feed too great; fixture not rigid

Hole oversize: Unequal angle of the cutting edges; unequal length of the cutting edges; see part (a)

Chip shape changes while drilling: Dull drill or cutting lips chipped

Large chip coming from one flute, small chip from the other: Point improperly ground, one lip doing all the cutting

Depth-to-Diameter Ratio

- Standard drills typically are used to produce holes with a depth to diameter ratio of 3:1
- Deeper holes result in drift of the tool decreasing hole straightness
- Specialized drills called deep-hole drills or gundrills are used for greater ratios
- Gundrills are single tipped tools with a coolant channel delivering coolant to the tip and flushing chips to the surface
- Ratios of 100:1 are possible with gundrills

Gundrills Geometry

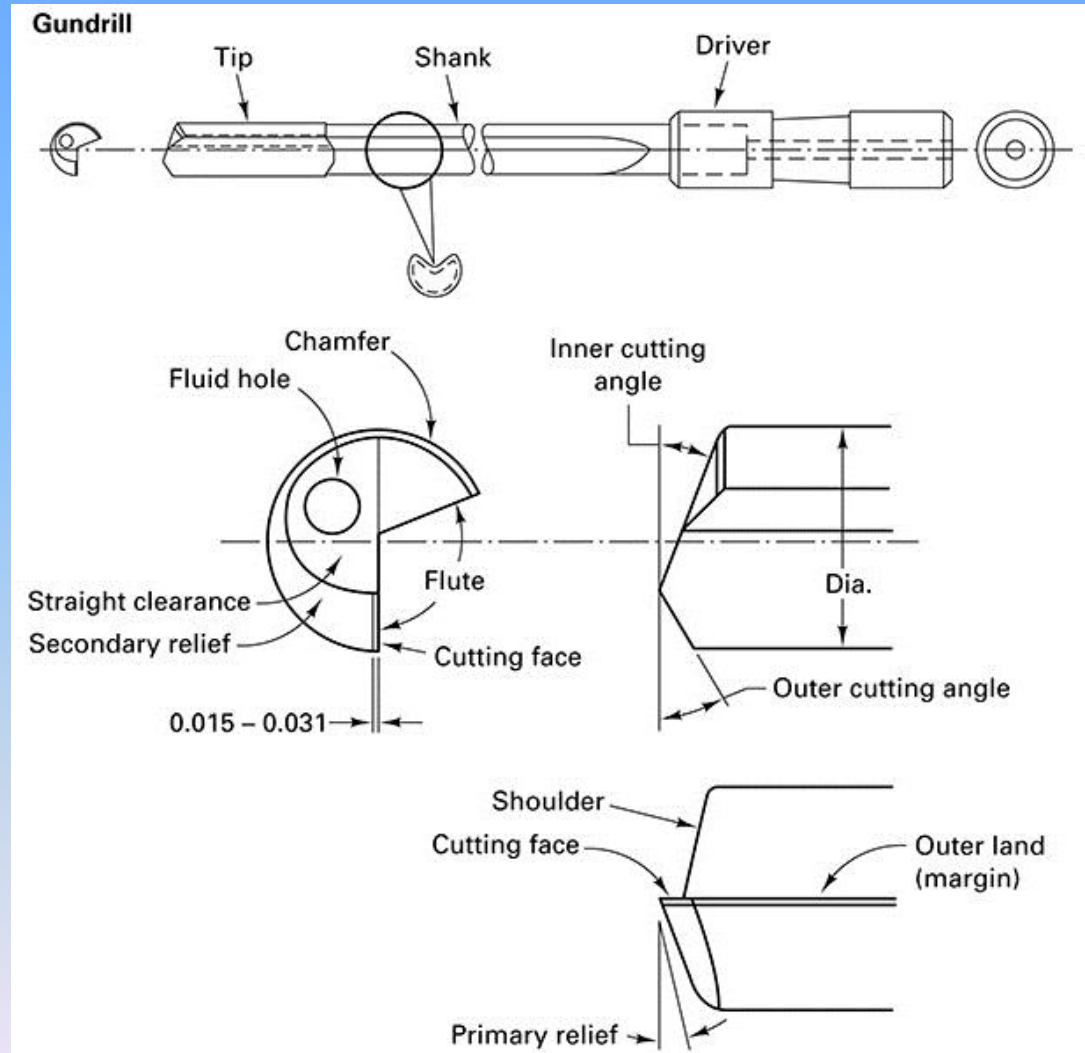
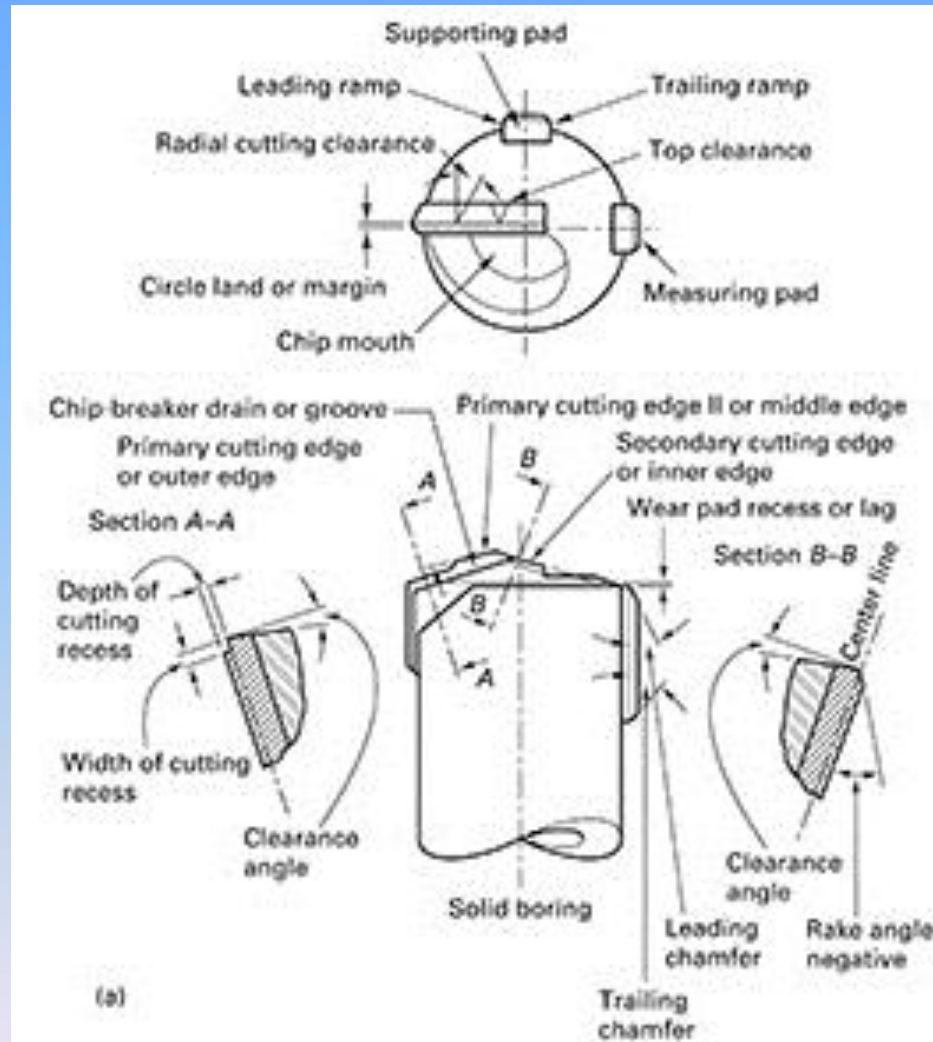

FIGURE 23-7 The gundrill geometry is very different from that of conventional drills.

Boring Trepanning Association (BTA)

- BTA drills are a another form of deep-boring drills
- BTA drills are also referred to as ejector drills
- Depth of hole is limited to the torsional rigidity of the drill shank
- BTA drills have a hollow center where the chips are carried way from the cutting surface

BTA Drills for Boring



BTA for Trepanning and Counterboring

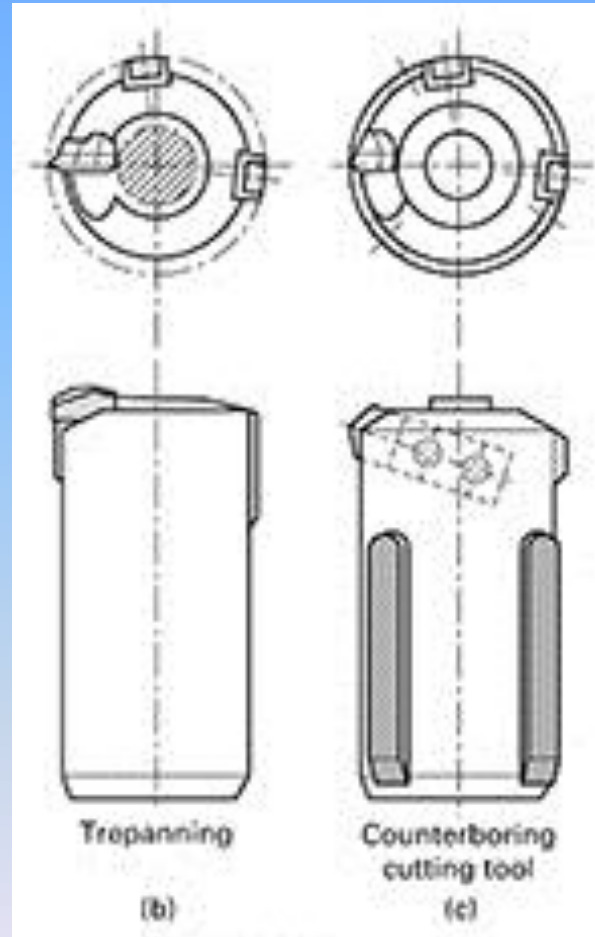

BTA for Deep-hole Drilling with Ejector Drill

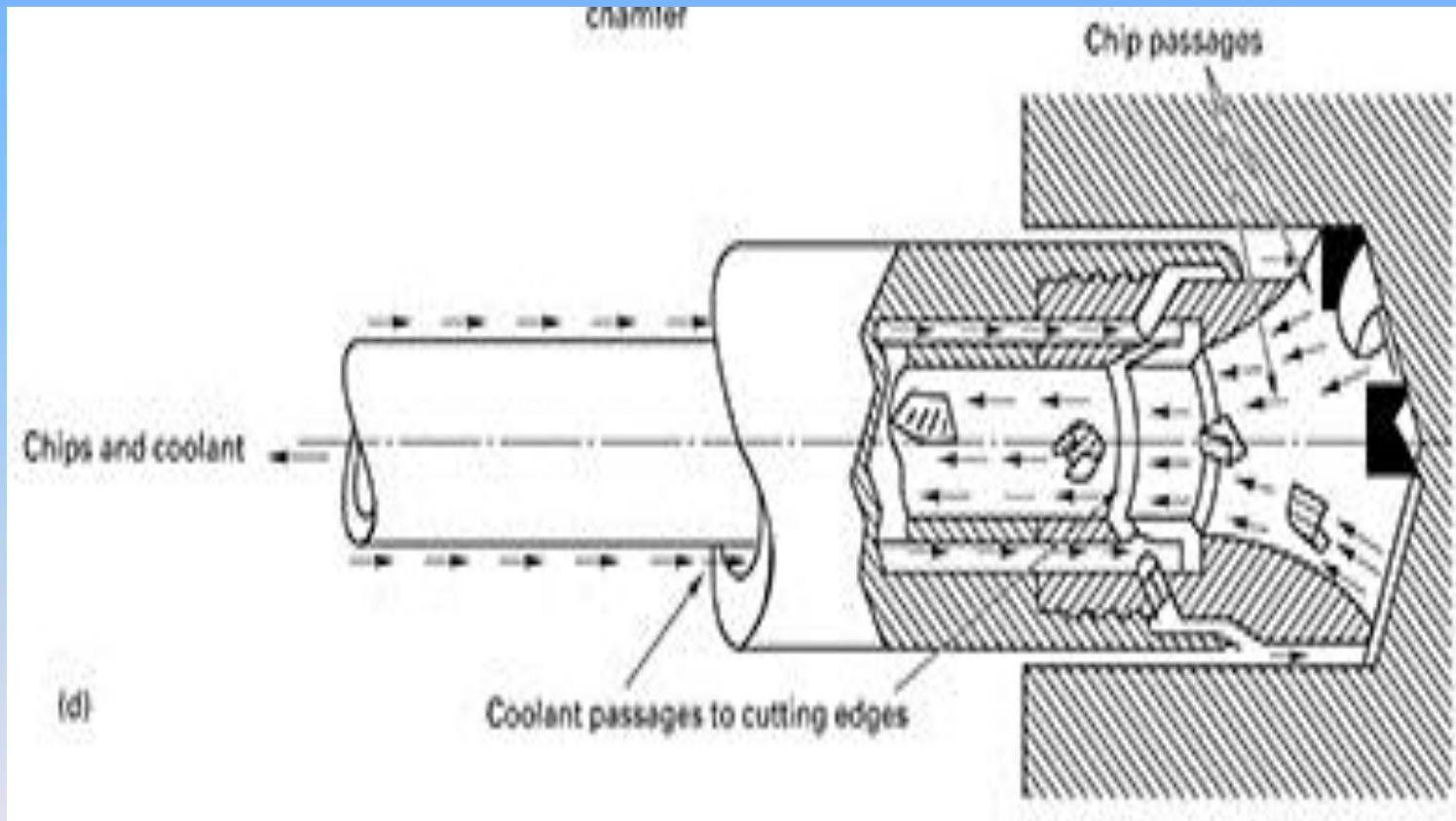

BTA for Horizontal Deep-drilling Machine

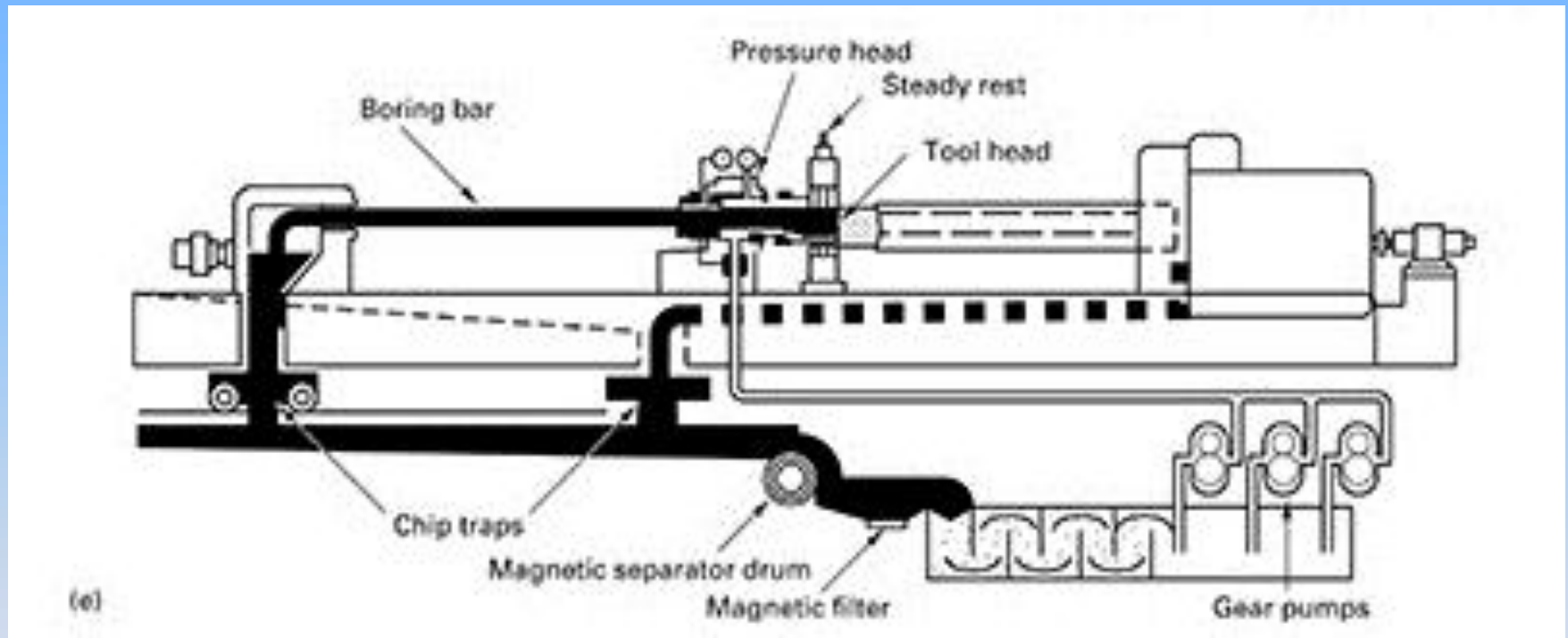

Steps to High Accuracy Holes with Conventional Drills

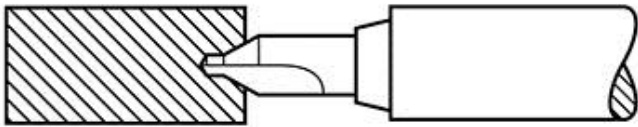

Step 1 Centering and countersinking with a combination center drill and countersink.
(Courtesy of Chicago-Latrobe)

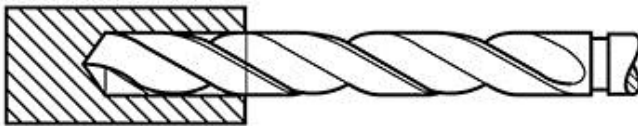

Step 2 Drilling with a standard twist drill.

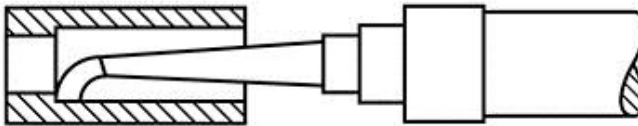

Step 3 Truing hole by boring.

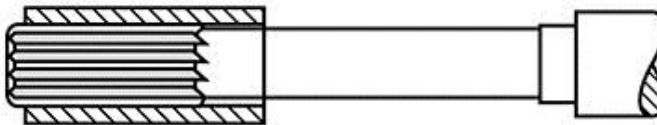

Step 4 Final sizing and finishing with a reamer.

FIGURE 23-10 To obtain a hole that is accurate as to size and aligned on center (located), this 4 step sequence of operations is usual.

Specialty Drills

- Hole cutters: used for holes in sheet stock
- Subland drills: used for multi diameter holes
- Spade drills: used for holes over 1 inch
- Indexable drills: used for high speed shallow holes in solid stock
- Micro drills (pivot drills): used for holes 0.02 to 0.0001 inch diameter where grain boundaries and inclusion produce non-uniform material properties

Hole Cutters for Used Sheets

- When cutting large holes in sheet stock, a hole cutter is used
- Hole cutters have a pilot drill in the center used to accurately locate the center
- Also called a hole saw



Subland Drill

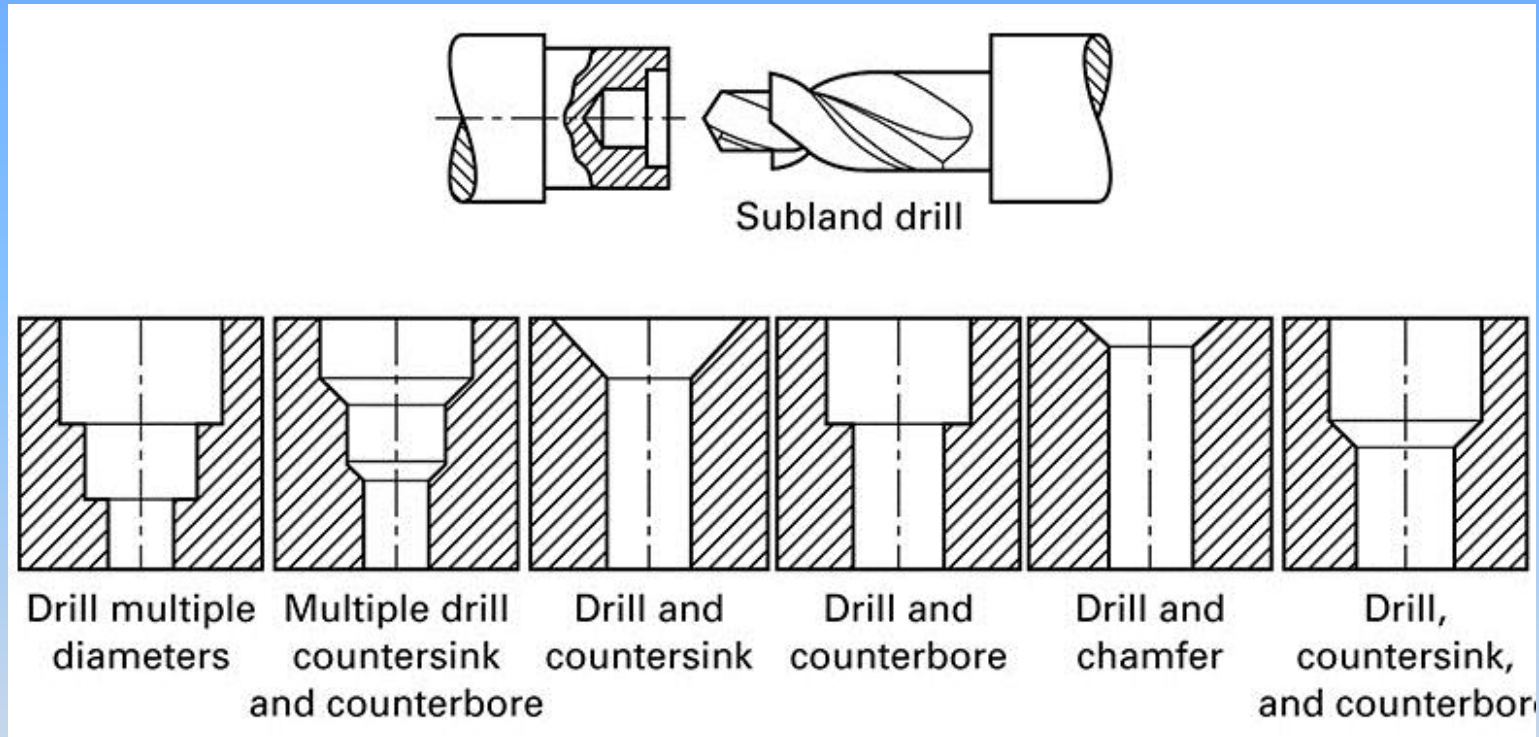
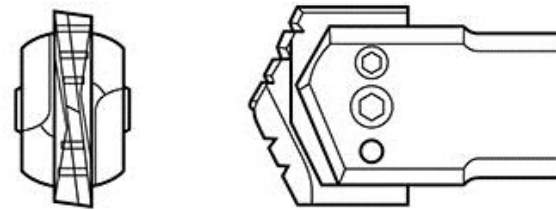

FIGURE 23-11 Special purpose subland drill (above), and some of the operations possible with other combination drills (below).

Spade Drills



Regular spade drill



Spade drill with oil holes

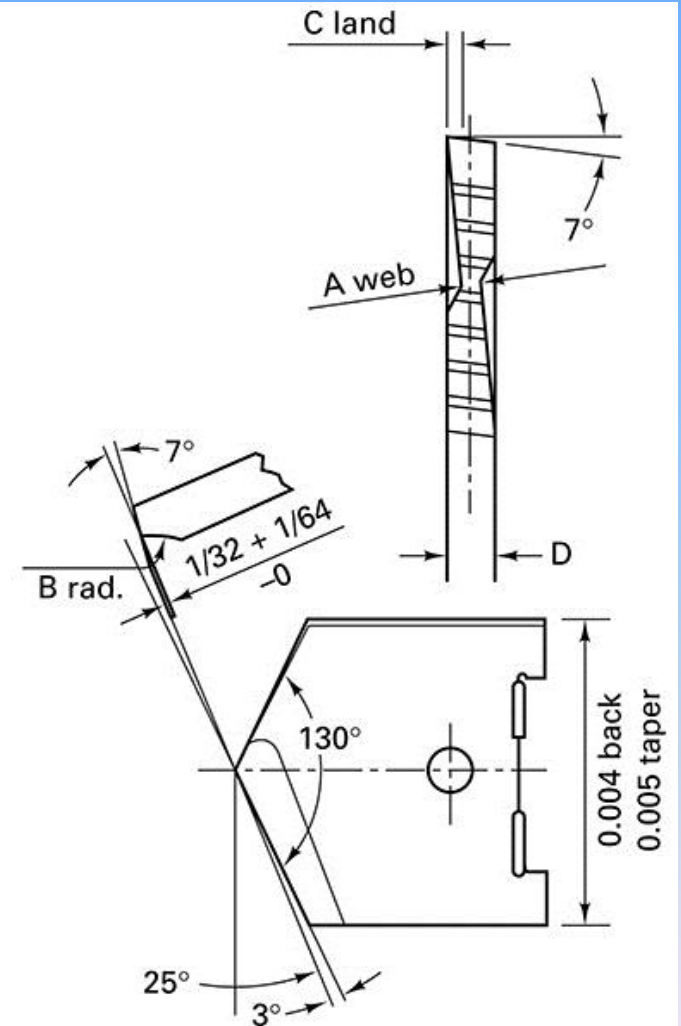

FIGURE 23-12 (Top) Regular spade drill; (middle) spade drill with oil holes; (bottom) spade drill geometry, nomenclature.

Indexable Drills



FIGURE 23-13 One- and two lipped indexable insert drills are widely used for holes over 1 inch in diameter. (Courtesy of Waukesha.)

Microdrills

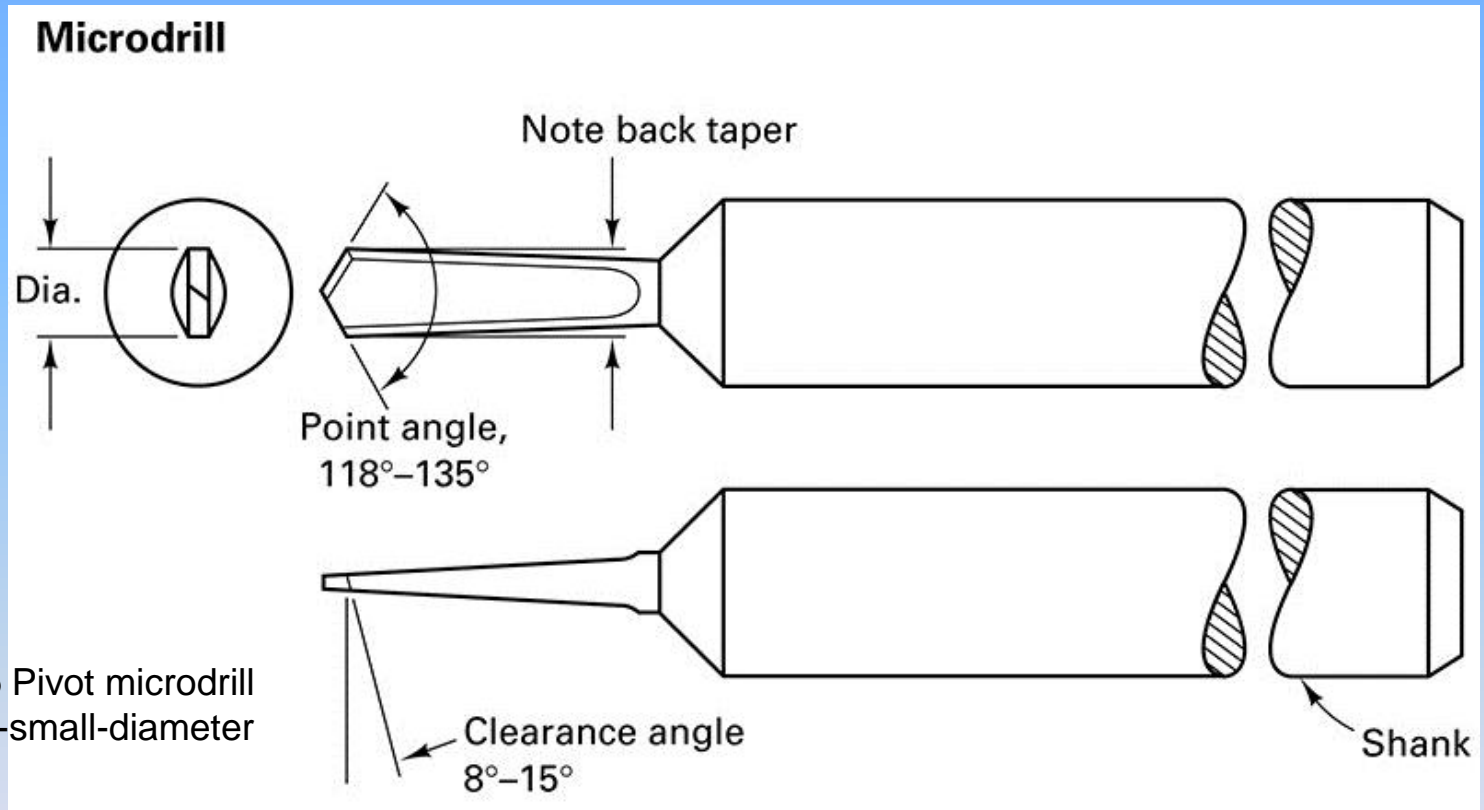

FIGURE 23-15 Pivot microdrill for drilling very-small-diameter holes.

23.4 Tool Holders for Drills

- Straight-shank drills are typically held in chucks
 - Three-jaw jacob's chucks: used on manual drill presses, require use of a key
 - Collet chuck: used with carbide tools where high bearing thrust is used
 - Quick change chucks: used where rapid change is needed
- Tapered shank drills held in Morse taper of the machine spindle

Drill Chucks

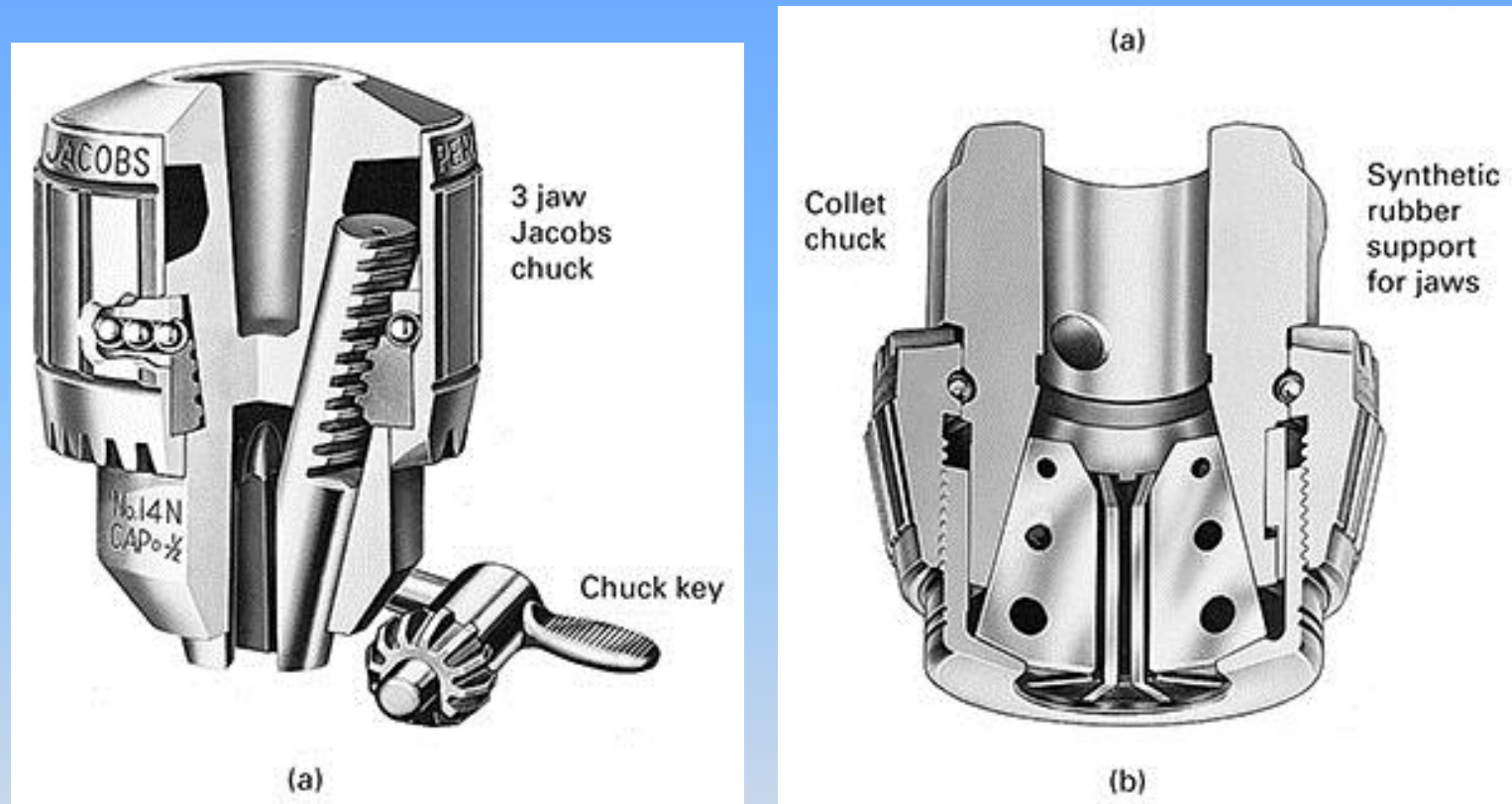
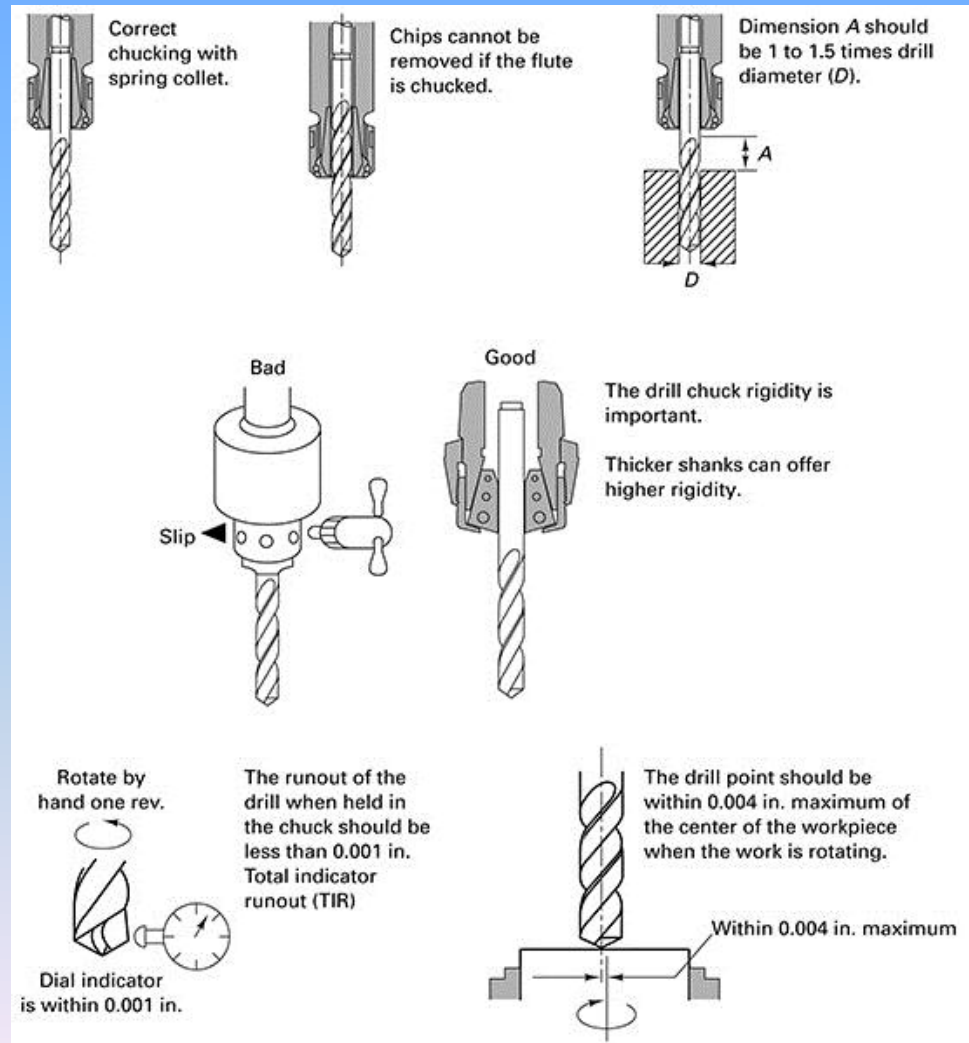

FIGURE 23-16 Two of the most commonly used types of drill chucks are the 3-jaw Jacobs chuck (above) and the collet chuck with synthetic rubber support for jaws. (Courtesy of Jacobs Manufacturing Company.)

Correct Chucking of Carbide Drills

FIGURE 23-17 Here are some suggestions for correct chucking of carbide drills.



23.5 Workholding for Drilling

- For prototype pieces, stock material is held in simple clamping vises
- For high production rates, custom jigs are used
- Stock material is never to be held on the work table by hand

23.6 Machine Tools for Drilling

- Drilling can be performed on:
 - Lathes
 - Vertical mills
 - Horizontal mills
 - Boring machines
 - Machine centers
- Specialized machines designed specifically for drilling called “drill presses”

Requirements of a Drill Press

- Drill presses must have sufficient power and thrust to perform cut
- Drill presses must be rigid enough to prevent chatter
- Drill press consist of a base, a work table, and a column that supports the powerhead and spindle

Specialized Drill Presses

- Gang-drilling machines: independent columns, each with different drilling operation, work piece slid from one column to next
- Turret-type, upright drilling machines: used when numerous drilling operation are required in rapid succession, turret rotates needed tool into position for each operation
- Radial drilling machines: used on large workpieces, spindle mounts on radial arm, allowing drilling operations anywhere along the arm length

Specialized Drill Presses

- Semiuniversal and universal machines: On a universal machine the spindle head can be rotated about the horizontal axis to any angle, semiuniversal can be rotated to a limited degree
- Multiple-spindle drilling machines: Single powerhead operates multiple spindles enabling multiple holes at one time, each hole can be unique
- Deep-hole drilling machines

23.7 Cutting Fluids for Drilling

TABLE 23-5 Cutting Fluids for Drilling

Work Material	Cutting Fluid
Aluminum and its alloys	Soluble oil, kerosene, and lard-oil compounds; light, nonviscous neutral oil; kerosene and soluble oil mixtures
Brass	Dry or a soluble oil; kerosene and lard-oil compounds; light, nonviscous neutral oil
Copper	Soluble oil, strained lard oil, oleic-acid compounds
Cast iron	Dry or with a jet of compressed air for cooling
Malleable iron	Soluble oil, nonviscous neutral oil
Monel metal	Soluble oil, sulfurized mineral oil
Stainless steel	Soluble oil, sulfurized mineral oil
Steel, ordinary	Soluble oil, sulfurized oil, high extreme-pressure-value mineral oil
Steel, very hard	Soluble oil, sulfurized oil, turpentine
Wrought iron	Soluble oil, sulfurized oil, mineral-animal oil compound

- Neat oil can be used effectively with the solid carbide drills for low-speed drilling (up to 130 sfpm).
- If the work surface becomes hard or blue in color, decrease the rpm and use neat oil.
- For heavy-duty cutting, emulsion-type oil containing some extreme pressure additive is recommended.
- A volume of 3.0 gal/min at a pressure of 37–62 lb/in.² is recommended.
- A double stream supply of fluid is recommended.

23.8 Counterboring, Countersinking, and Spot Facing

- Counterboring: Follows a drilling operation, or in with drilling with a custom tool. Purpose is to produce a flat bottom so that bolt head or nut is below the surface with enough clearance for a tool.
- Countersinking: Similar to counterboring, but with a 60° , 82° , or 90° beveled bottom to accommodate flat-head screw or rivet.
- Spot facing: Machine minimum depth and diameter around hole to ensure full seating of a bolt head. Used on rough stock surfaces where corrosion or fatigue requirements require full seating.

Counterboring and Countersinking Tools

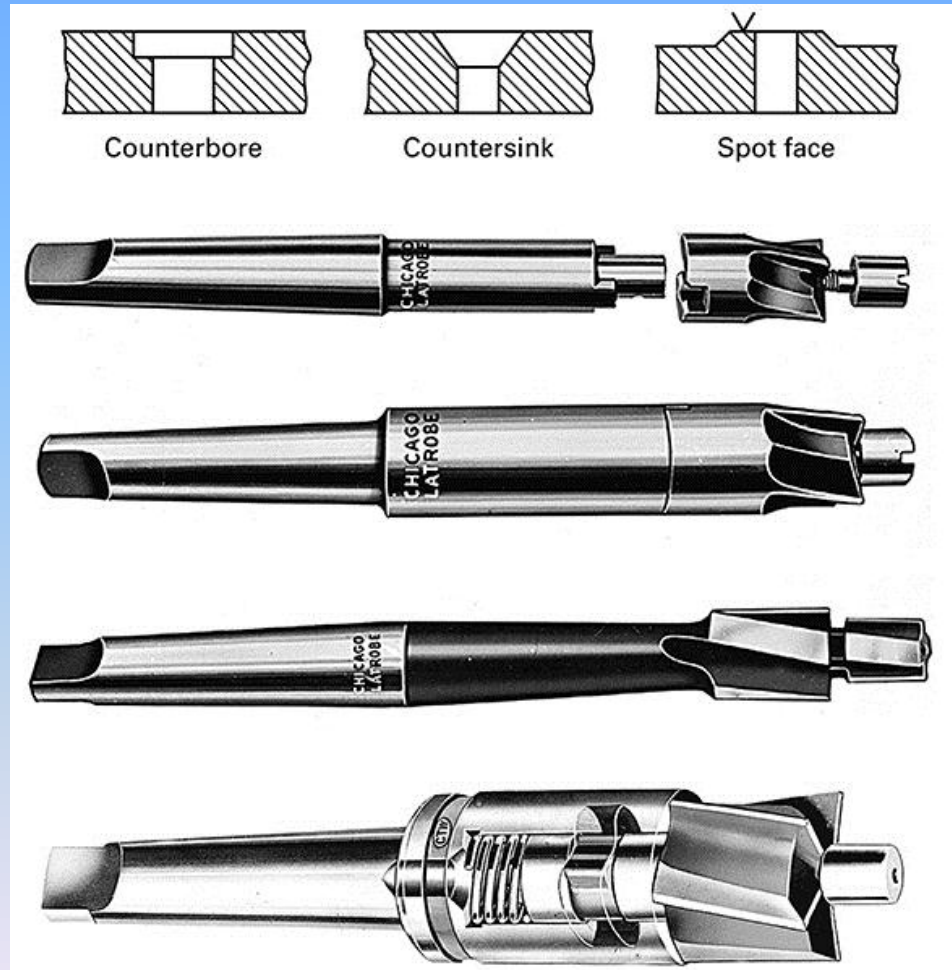

FIGURE 23-21 (a) Surfaces produced by counterboring, countersinking, and spot facing. (b) Counterboring tools: (bottom to top) interchangeable counterbore; solid, taper-shank counterbore with integral pilot; replaceable counterbore and pilot; replaceable counterbore, disassembled. (Courtesy of Ex-Cell-O Corporation and Chicago Latrobe Twist Drill Works.)

23.9 Reaming

- Reams remove small amounts of material to ensure exact hole size and improve hole surface finish
- Reams are either hand operated or machined at slow speed
- Ream types
 - Shell reams
 - Expansion reams
 - Adjustable reams
 - Tapered reams

Ream Geometry

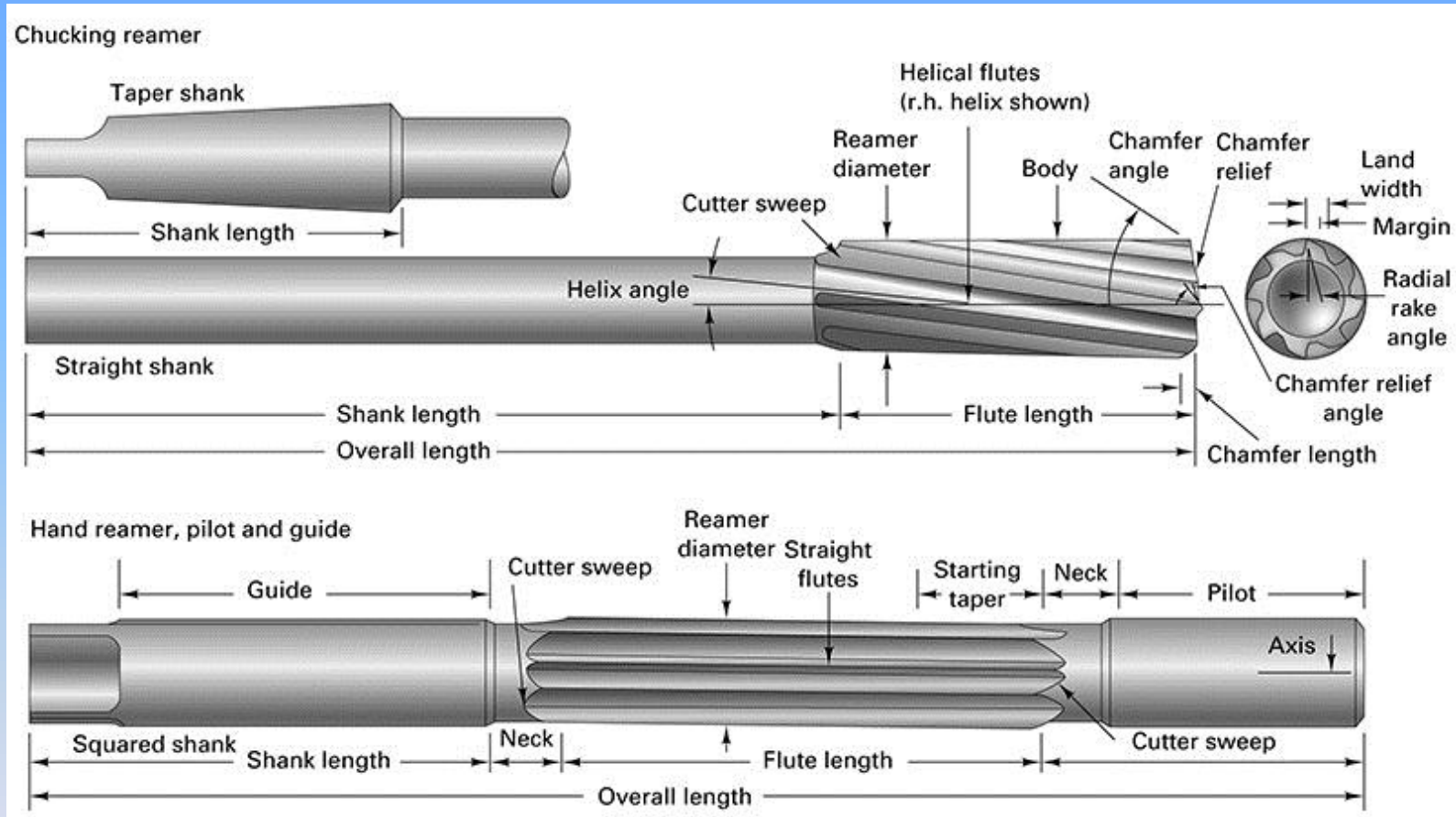
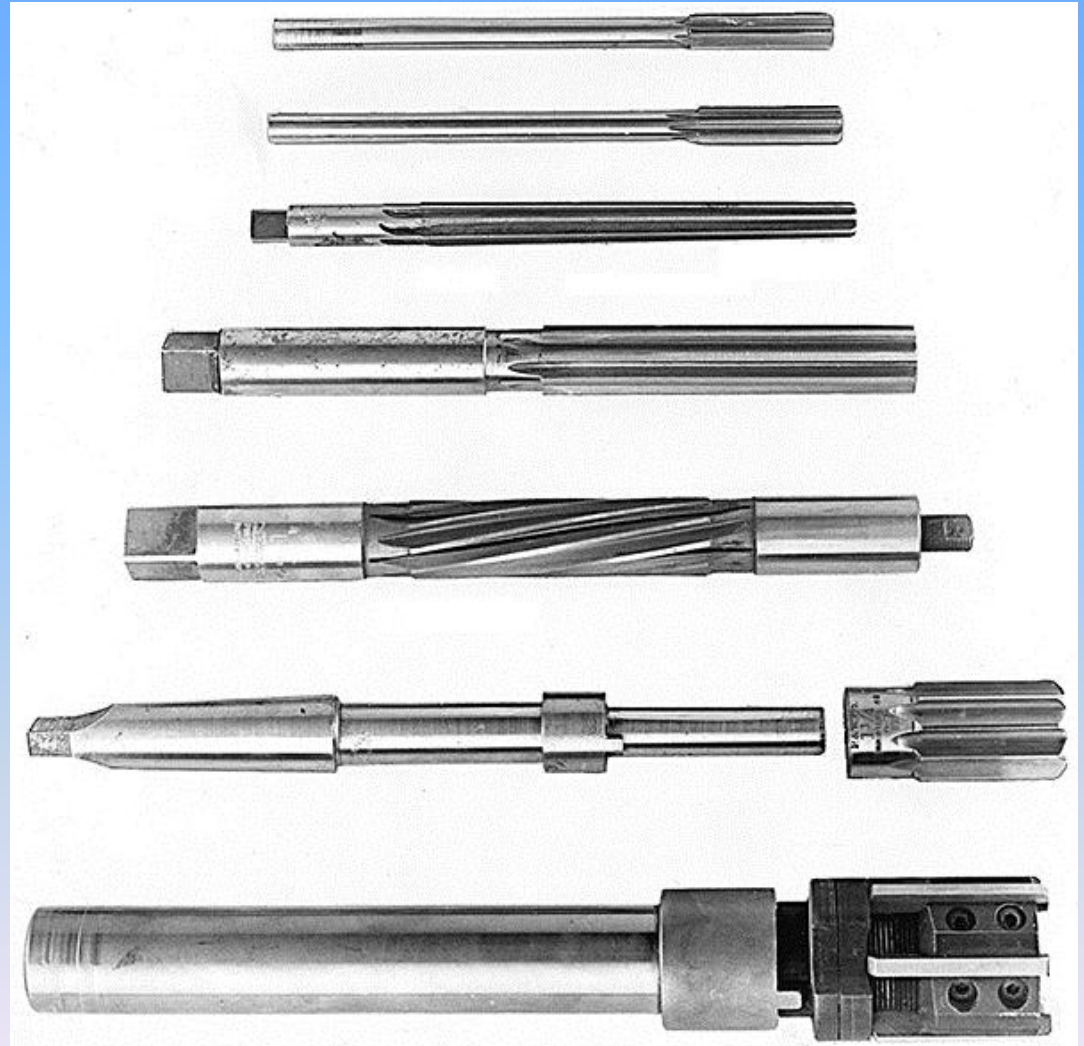

FIGURE 23-22 Standard nomenclature for hand and chucking reamers.

Types of Reams

FIGURE 23-23 Types of reamers: (top to bottom) Straightfluted rose reamer, straight-fluted chucking reamer, straight-fluted taper reamer, straight-fluted hand reamer, expansion reamer, shell reamer, adjustable insertblade reamer.



Summary

- Drilling is the most common machining operation
- Drilling can be performed on a number of machine tools, drill presses are specialized machine tools for drilling only
- Drills come in a wide variety of types and tip geometries depending upon production rate and accuracy needed
- Hole geometries can be adjusted through the use of counterboring, countersinking and reaming