

# Fundamentals of Casting

## Chapter 11

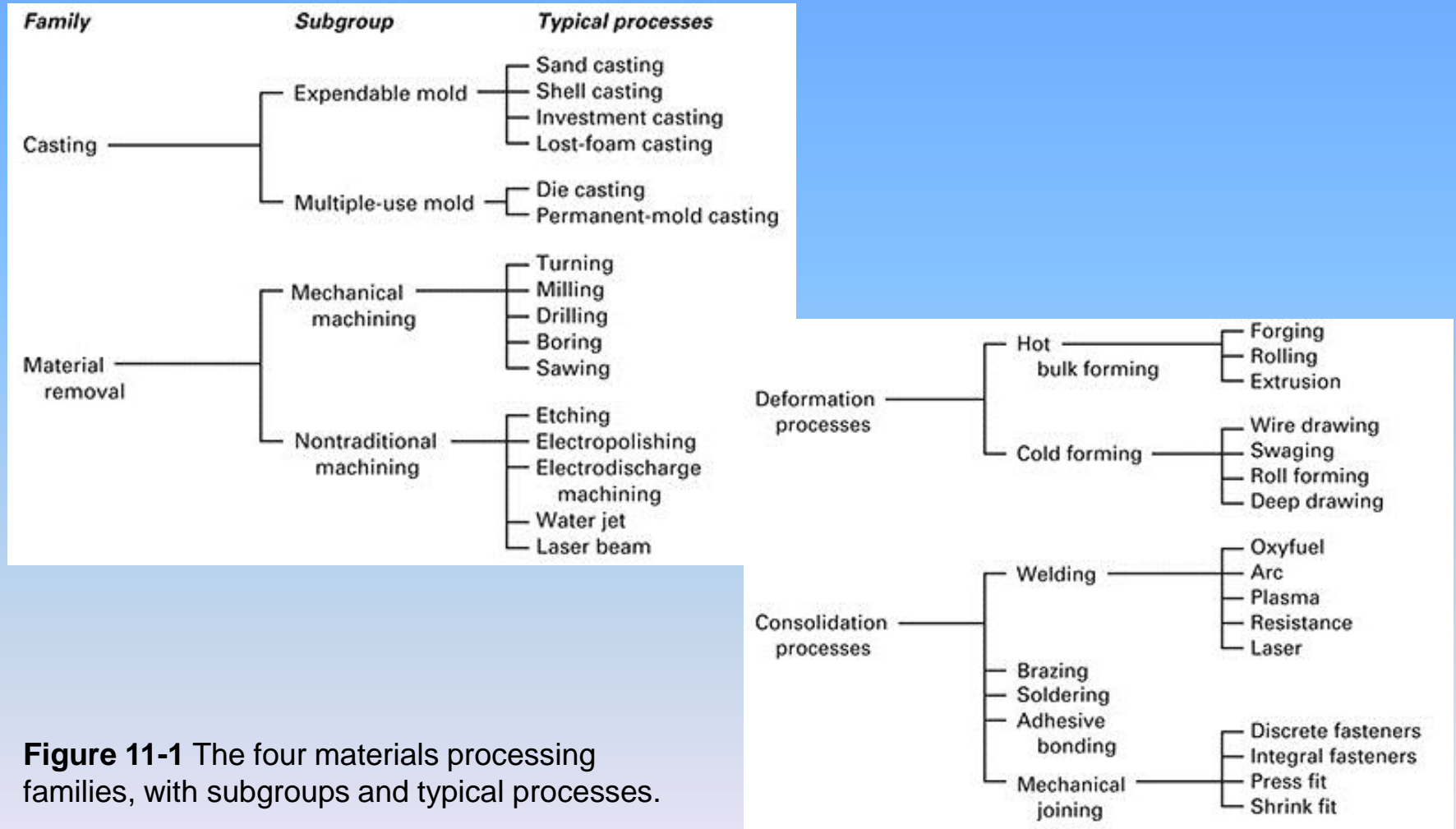
# 11.1 Introduction

- Products go through a series of processes before they are produced
  - Design
  - Material selection
  - Process selection
  - Manufacture
  - Inspection and evaluation
  - Feedback
- Materials processing is the science and technology that converts a material into a product of a desired shape in the desired quantity

# Shape-Producing Processes

- Four basic categories
  - Casting processes
  - Material removal processes
  - Deformation processes
  - Consolidation processes
- Decisions should be made after all alternatives and limitations are investigated

# Shape-Producing Processes



**Figure 11-1** The four materials processing families, with subgroups and typical processes.

# 11.2 Introduction to Casting

- Casting process
  - Material is melted
  - Heated to proper temperature
  - Treated to modify its chemical makeup
  - Molten material is poured into a mold
  - Solidifies
- Casting can produce a large variety of parts

# Advantages of Casting

- Complex shapes
- Parts can have hollow sections or cavities
- Very large parts
- Intricate shaping of metals that are difficult to machine
- Different mold materials can be used
  - Sand, metal, or ceramics
- Different pouring methods

# Basic Requirements of Casting Processes

- Six basic steps of casting
  - 1. Mold cavity is produced having the desired shape and size of the part
    - Takes shrinkage into account
    - Single-use or permanent mold
  - 2. Melting process
    - Provides molten material at the proper temperature
  - 3. Pouring technique
    - Molten metal is poured into the mold at a proper rate to ensure that erosion and or defects are minimized

# Six Basic Steps of Casting

- 4. Solidification process
  - Controlled solidification allows the product to have desired properties
  - Mold should be designed so that shrinkage is controlled
- 5. Mold removal
  - The casting is removed from the mold
    - Single-use molds are broken away from the casting
    - Permanent molds must be designed so that removal does not damage the part
- 6. Cleaning, finishing, and inspection operations
  - Excess material along parting lines may have to be machined



# 11.3 Casting Terminology

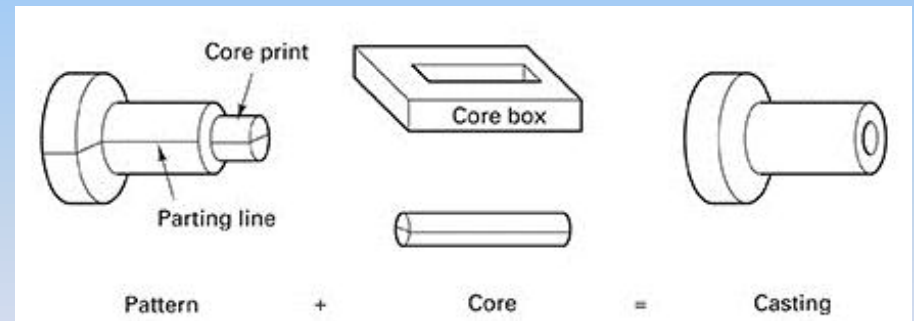
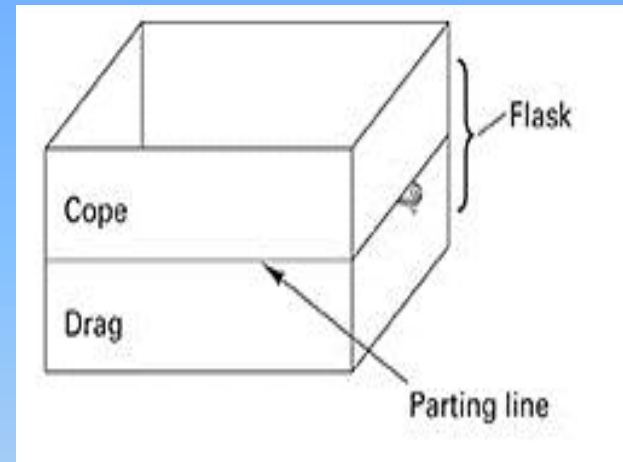
- Pattern- approximate duplicate of the part to be cast
- Molding material- material that is packed around the pattern to provide the mold cavity
- Flask- rigid frame that holds the molding aggregate
- Cope- top half of the pattern
- Drag- bottom half of the pattern
- Core- sand or metal shape that is inserted into the mold to create internal features

# Casting Terminology

- Mold cavity- combination of the mold material and cores
- Riser-additional void in the mold that provides additional metal to compensate for shrinkage
- Gating system- network of channels that delivers the molten metal to the mold
- Pouring cup- portion of the gating system that controls the delivery of the metal
- Sprue- vertical portion of the gating system
- Runners- horizontal channels
- Gates- controlled entrances

# Casting Terminology

- Parting line- separates the cope and drag
- Draft- angle or taper on a pattern that allows for easy removal of the casting from the mold
- Casting- describes both the process and the product when molten metal is poured and solidified



**Figure 11-2** Cross section of a typical two-part sand mold, indicating various mold components and terminology.

# Cross Section of a Mold

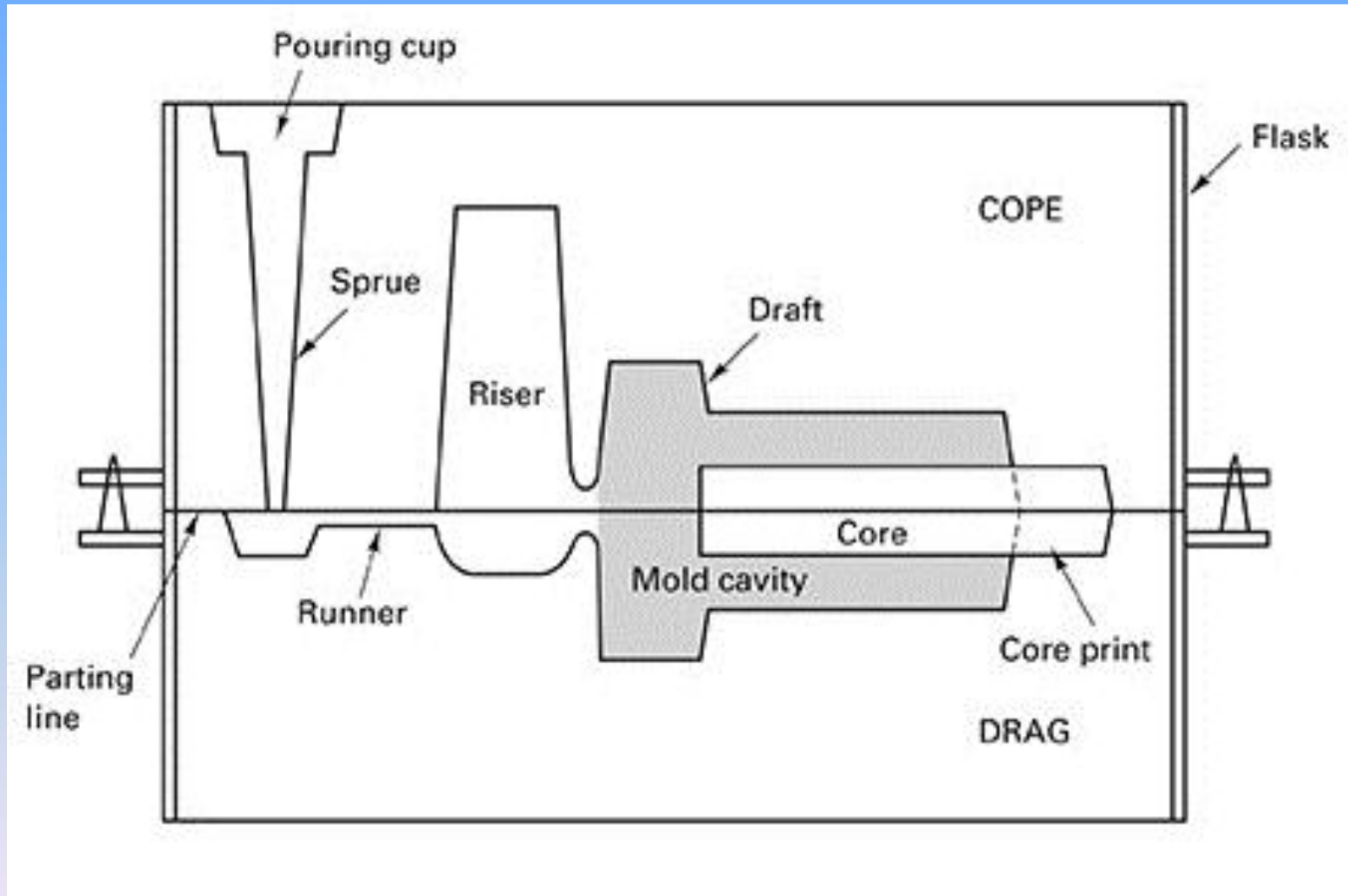


Figure 11-2 Cross section of typical two-part sand mold

# 11.4 The Solidification Process

- Molten material is allowed to solidify into the final shape
- Casting defects occur during solidification
  - Gas porosity
  - Shrinkage
- Two stages of solidification
  - Nucleation
  - Growth

# Nucleation

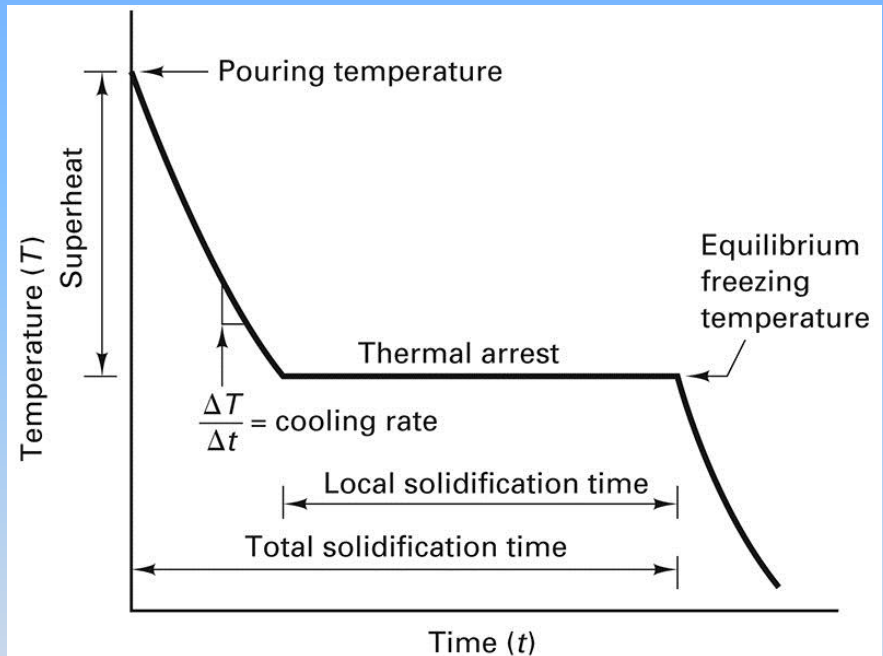
- Stable particles form from the liquid metal
- Occurs when there is a net release of energy from the liquid
- Undercooling is the difference between the melting point and the temperature at which nucleation occurs
- Each nucleation event produces a grain
  - Nucleation is promoted (more grains) for enhanced material properties
  - Inoculation or grain refinement is the process of introducing solid particles to promote nucleation

# Grain Growth

- Occurs as the heat of fusion is extracted from the liquid
- Direction, rate, and type of growth can be controlled
  - Controlled by the way in which heat is removed
  - Rates of nucleation and growth control the size and shape of the crystals
  - Faster cooling rates generally produce finer grain sizes

# Cooling Curves

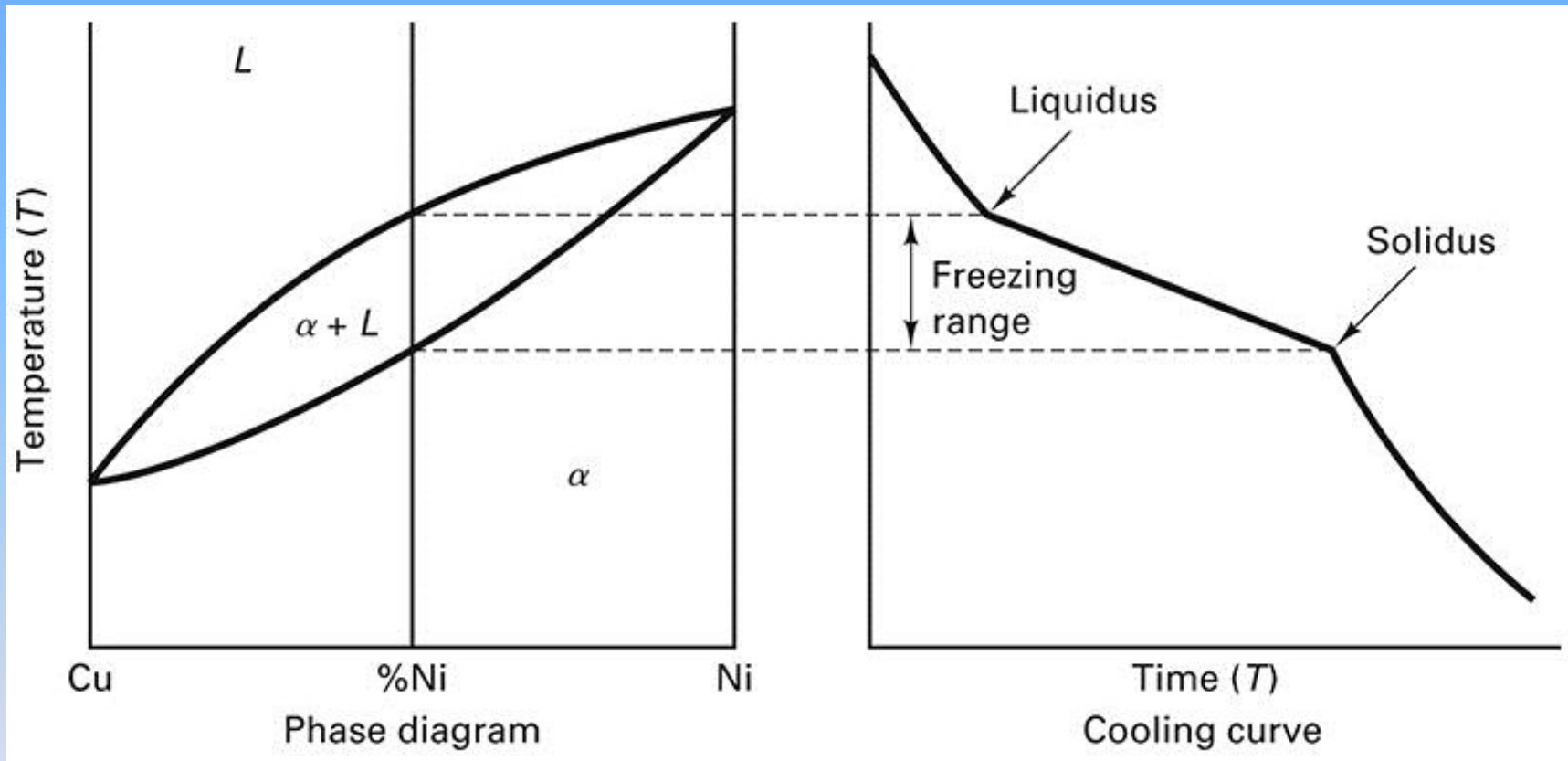
- Useful for studying the solidification process
- Cooling rate is the slope of the cooling curve
- Solidification can occur over a range of temperatures in alloys
- Beginning and end of solidification are indicated by changes in slope



**Figure 11-3** Cooling curve for a pure metal or eutectic-composition alloy (metals with a distinct freezing point), indicating major features related to solidification.



# Cooling Curves



**Figure 11-4** Phase diagram and companion cooling curve for an alloy with a freezing range. The slope changes indicate the onset and termination of solidification.

# Prediction of Solidification Time: Chvorinov's Rule

- Ability to remove heat from a casting is related to the surface area through which the heat is removed and the environment that it is rejecting heat to
- Chvorinov's Rule:
  - $t_s = B(V/A)^n$  where  $n=1.5$  to  $2.0$
- $t_s$  is the time from pouring to solidification
- $B$  is the mold constant
- $V$  is the volume of the casting
- $A$  is the surface area through which heat is rejected

# Cast Structure

- Three distinct regions or zones
  - Chill zone
    - Rapid nucleation that occurs when the molten metal comes into contact with the cold walls of the mold
    - Forms a narrow band of randomly oriented crystals on the surface of a casting
  - Columnar zone
    - Rapid growth perpendicular to the casting surface
    - Long and thin
    - Highly directional
  - Equiaxed zone
    - Crystals in the interior of the casting
    - Spherical, randomly oriented crystals

# Cast Structure

**TABLE 11-1** Comparison of As-Cast Properties of 443 Aluminum Cast by Three Different Processes

Process	Yield Strength (ksi)	Tensile Strength (ksi)	Elongation (%)
Sand cast	8	19	8
Permanent mold	9	23	10
Die cast	16	33	9

<sup>1</sup>N. Chvorinov, "Theory of Casting Solidification", Giesserei, Vol. 27, 1940, pp. 177-180, 201-208, 222-225.

**Figure 11-5** Internal structure of a cast metal bar showing the chill zone at the periphery, columnar grains growing toward the center, and a central shrinkage cavity.



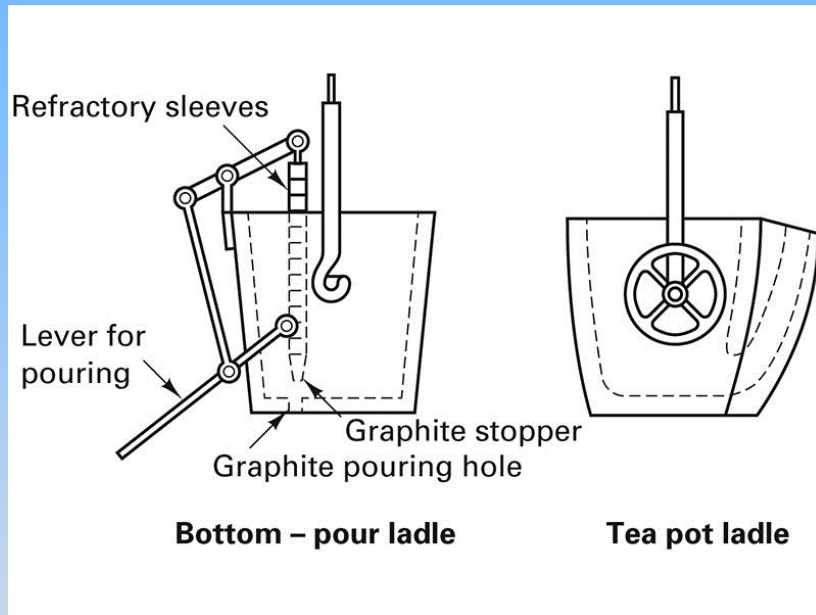
# Molten Metal Problems

- Chemical reactions can occur between molten metal and its surroundings
- Reactions can lead to defects in the final castings
  - Metal oxides may form when molten metal reacts with oxygen
  - Dross or slag is the material that can be carried with the molten metal during pouring and filling of the mold
    - Affects the surface finish, machinability, and mechanical properties

# Molten Metal Problems

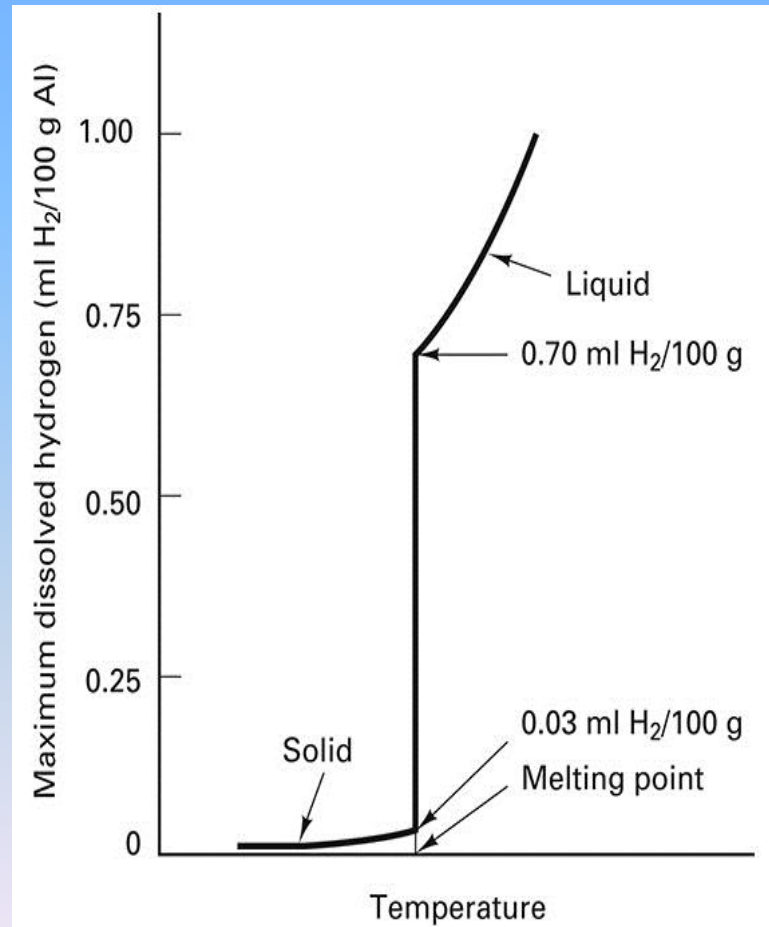
- Gas porosity
  - Gas that is not rejected from the liquid metal may be trapped upon solidification
  - Several techniques to prevent gas porosity
    - Prevent the gas from initially dissolving in the liquid
      - Melting can be done in a vacuum
      - Melting can be done in environments with low-solubility gases
      - Minimize turbulence
    - Vacuum degassing removes the gas from the liquid before it is poured into the castings
    - Gas flushing- passing inert gases or reactive gases through the liquid metal

# Molten Metal Problems



**Figure 11-6** Two types of ladles used to pour castings. Note how each extracts molten material from the bottom, avoiding transfer of the impure material from the top of the molten pool.

**Figure 11-7** (Below) The maximum solubility of hydrogen in aluminum as a function of temperature.



# Fluidity and Pouring Temperature

- Metal should flow into all regions of the mold cavity and then solidify
- Fluidity is the ability of a metal to flow and fill a mold
  - Affects the minimum section thickness, maximum length of a thin section, fineness of detail, ability to fill mold extremities
  - Dependent on the composition, freezing temperature, freezing range, and surface tension
- Most important controlling factor is pouring temperature



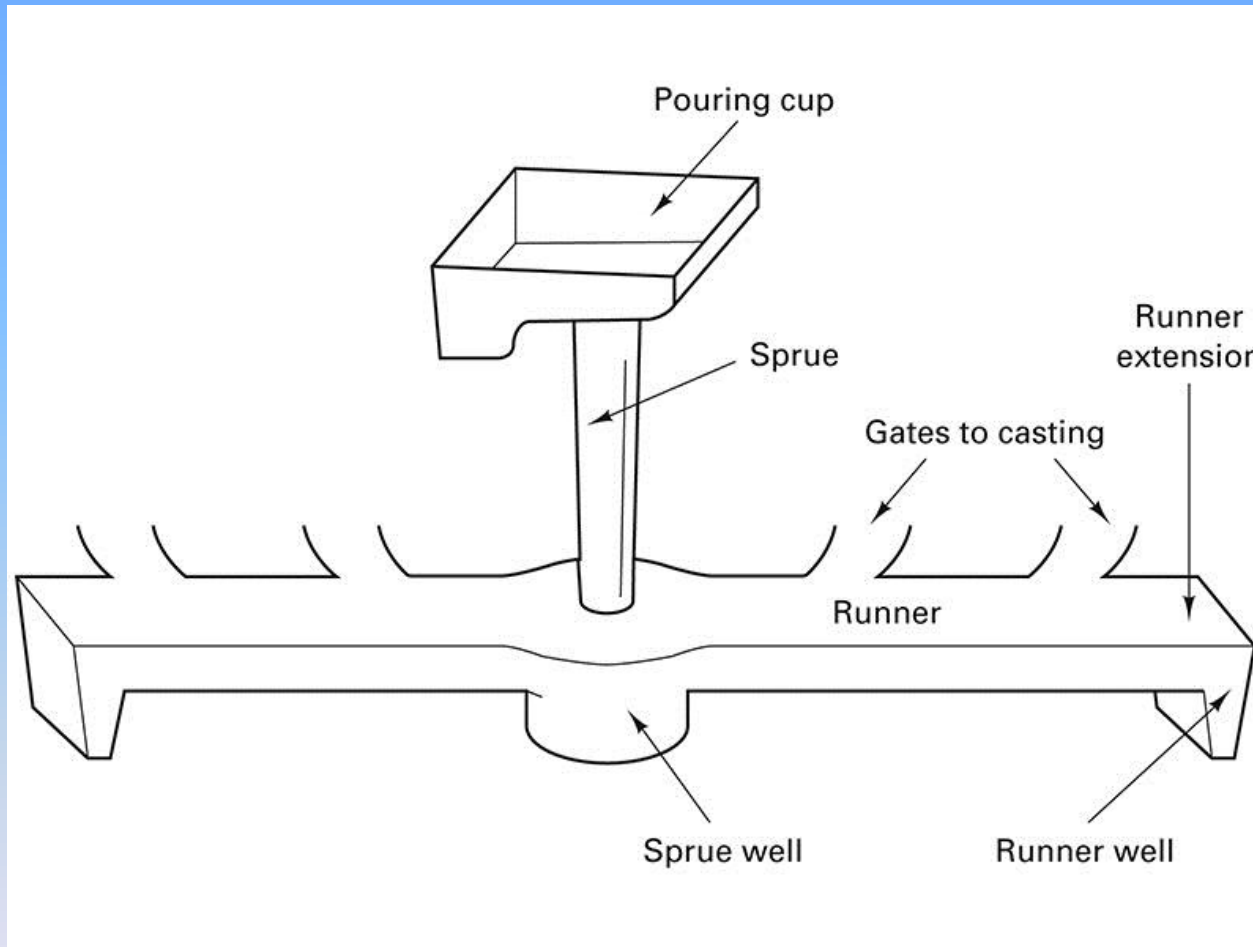
# The Role of the Gating System

- Gating system delivers the molten metal to the mold cavity
- Controls the speed of liquid metal flow and the cooling that occurs during flow
- Rapid rates of filling can produce erosion of the mold cavity
  - Can result in the entrapment of mold material in the final casting
  - Cross sectional areas of the channels regulate flows

# Gating Systems

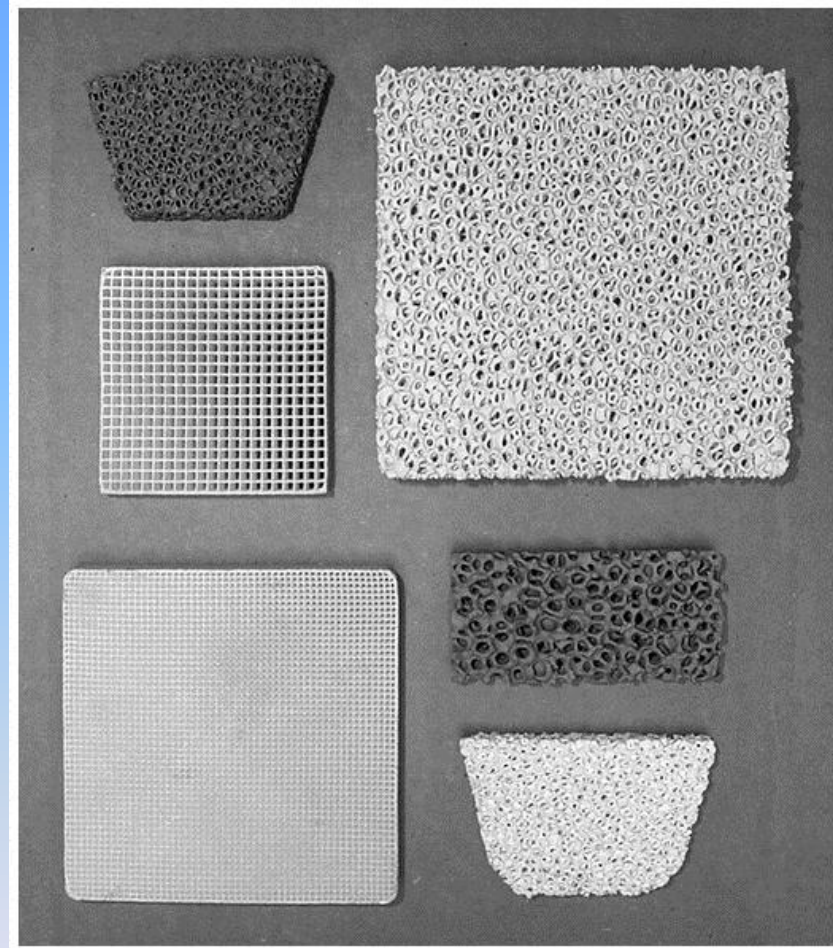
- Proper design minimizes turbulence
- Turbulence promotes absorption of gases, oxidation, and mold erosion
- Choke- smallest cross-sectional area in the gating system
- Runner extensions and wells- used to catch and trap the first metal to enter the mold and prevent it from entering the mold cavity
- Filters- used to trap foreign material

# Gating System



**Figure 11-9** Typical gating system for a horizontal parting plane mold, showing key components involved in controlling the flow of metal into the mold cavity.

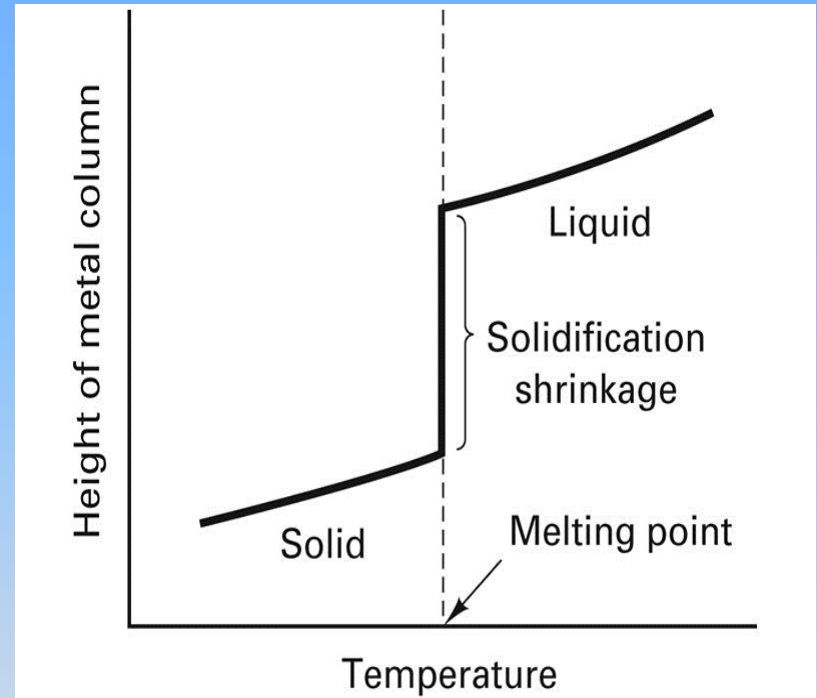
# Filters



**Figure 11-10** Various types of ceramic filters that may be inserted into the gating systems of metal castings.

# Solidification Shrinkage

- Most metals undergo noticeable volumetric contraction when cooled
- Three principle stages of shrinkage:
  - Shrinkage of liquid as it cools from the solidification temperature
  - Solidification shrinkage as the liquid turns into solid
  - Solid metal contraction as the solidified metal cools to room temperature



**Figure 11-11** Dimensional changes experienced by a metal column as the material cools from a superheated liquid to a room-temperature solid. Note the significant shrinkage that occurs upon solidification.

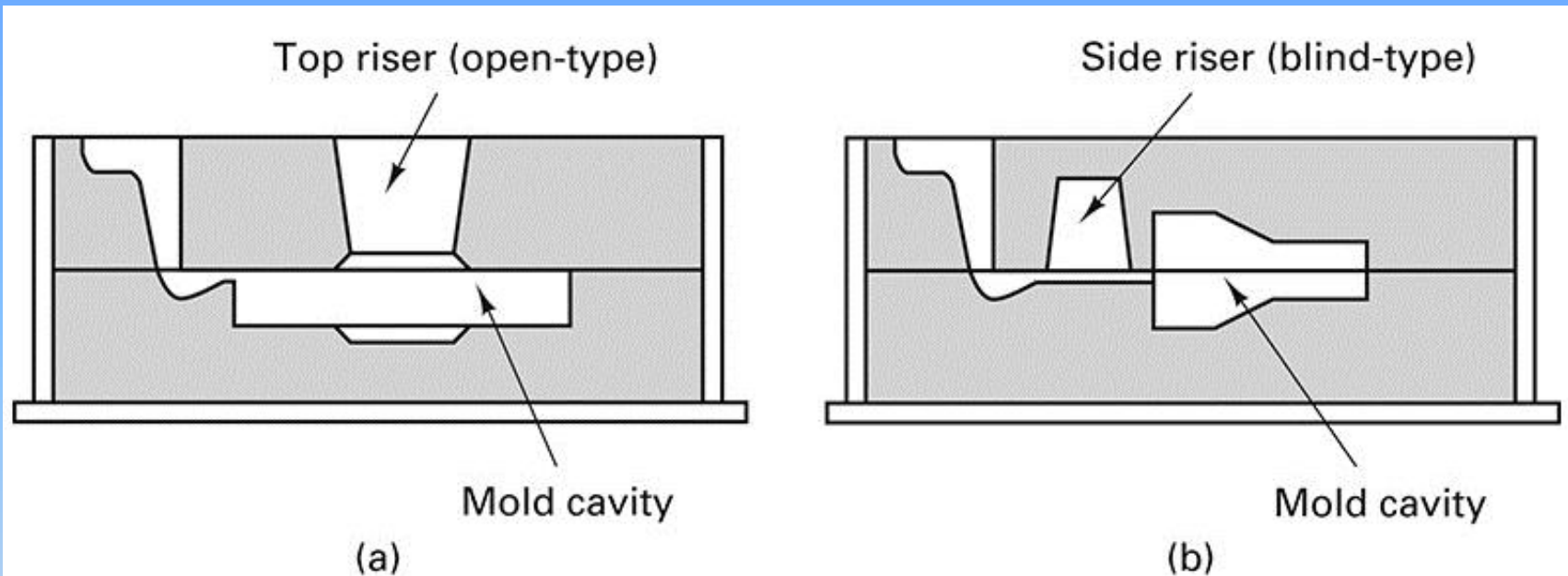
# Solidification Shrinkage

- Amount of liquid metal contraction depends on the coefficient of thermal contraction and the amount of superheat
- As the liquid metal solidifies, the atomic structure normally becomes more efficient and significant amounts of shrinkage can occur
- Cavities and voids can be prevented by designing the casting to have directional solidification
- Hot tears can occur when there is significant tensile stress on the surface of the casting material

# Risers and Riser Design

- Risers are reservoirs of liquid metal that feed extra metal to the mold to compensate for shrinkage
- Risers are designed to conserve metal
- Located so that directional solidification occurs from the extremities of the mold toward the riser
- Should feed directly to the thickest regions of the casting
- Blind riser- contained entirely within the mold cavity
- Live riser- receive the last hot metal that enters the mold

# Risers and Riser Design



**Figure 11-13** Schematic of a sand casting mold, showing a) an open-type top riser and b) a blind-type side riser. The side riser is a live riser, receiving the last hot metal to enter the mold. The top riser is a dead riser, receiving metal that has flowed through the mold cavity.

- Riser must be separated from the casting upon completion so the connection area must be as small as possible



# Riser Aids

- Riser's performance may be enhanced by speeding the solidification of the casting (chills) or slowing down the solidification (sleeves or toppings)
- External chills
  - Masses of high-heat capacity material placed in the mold
  - Absorb heat and accelerate cooling in specific regions
- Internal chills
  - Pieces of metal that are placed in the mold cavity and promote rapid solidification
  - Ultimately become part of the cast part

# 11.5 Patterns

- Two basic categories for casting processes
  - Expendable mold processes
  - Permanent mold processes
- Patterns are made from wood, metal, foam, or plastic
- Dimensional modification are incorporated into the design (allowances)
  - Shrinkage allowance is the most important
  - Pattern must be slightly larger than the desired part

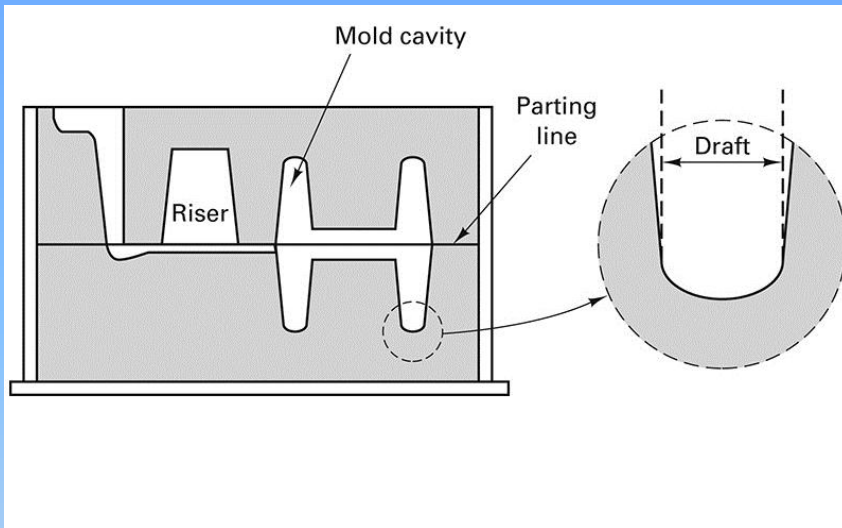
# Dimensional Allowances

- Typical allowances
  - Cast iron 0.8-1.0%
  - Steel 1.5-2.0%
  - Aluminum 1.0-1.3%
  - Magnesium 1.0-1.3%
  - Brass 1.5%
- Shrinkage allowances are incorporated into the pattern using shrink rules
- Thermal contraction might not be the only factor for determining pattern size
- Surface finishing operations (machining, etc.) should be taken into consideration

# Pattern Removal

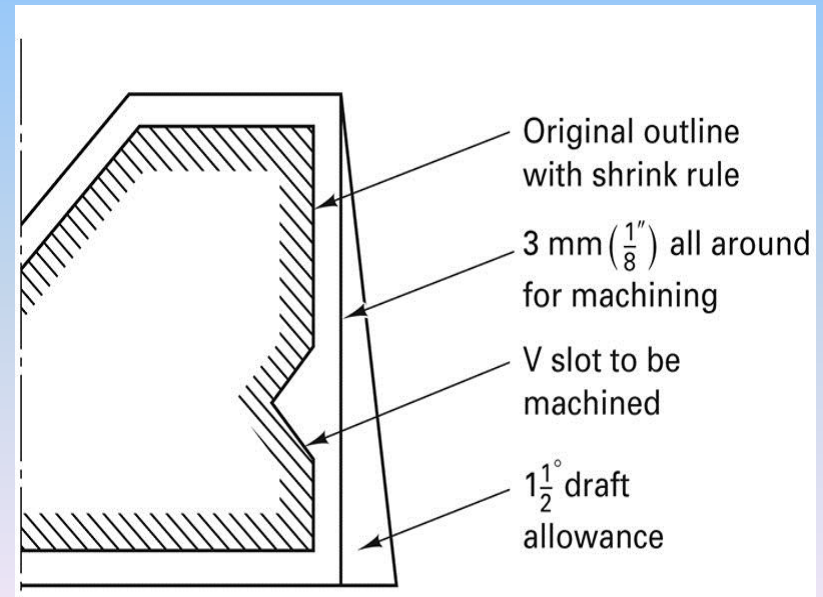
- Parting lines are the preferred method
- Damage can be done to the casting at corners or parting surfaces if tapers or draft angles are not used in the pattern
  - Factors that influence the needed draft
    - Size and shape of pattern
    - Depth of mold cavity
    - Method used to withdraw pattern
    - Pattern material
    - Mold material
    - Molding procedure

# Design Considerations



**Figure 11-14** Two-part mold showing the parting line and the incorporation of a draft allowance on vertical surfaces.

**Figure 11-15** Various allowances incorporated into a casting pattern.

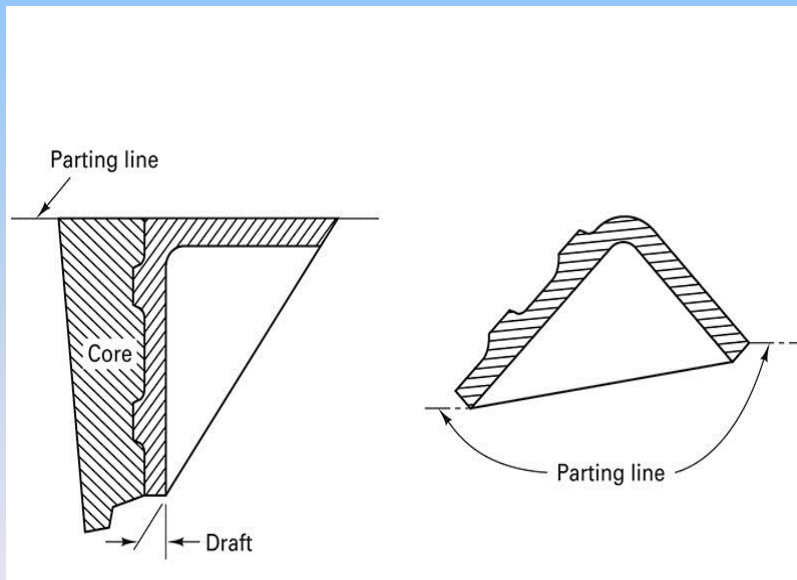
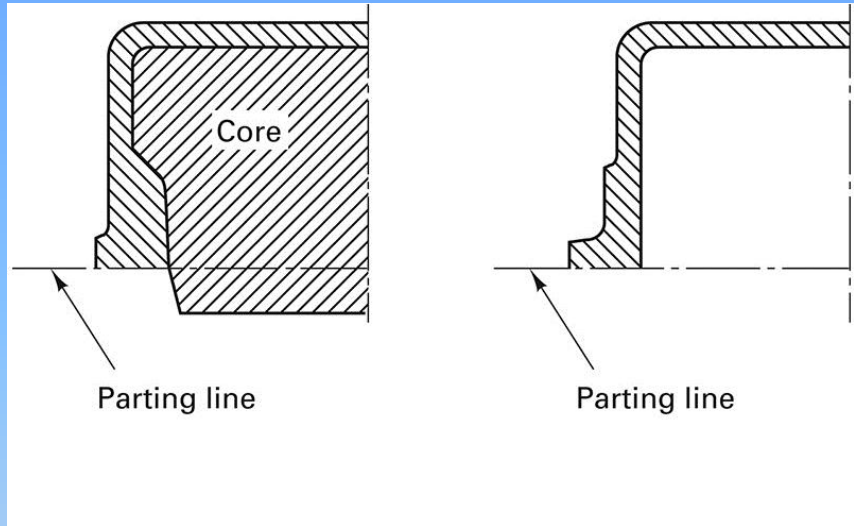


# 11.6 Design Considerations in Castings

- Location and orientation of the parting line is important to castings
- Parting line can affect:
  - Number of cores
  - Method of supporting cores
  - Use of effective and economical gating
  - Weight of the final casting
  - Final dimensional accuracy
  - Ease of molding

# Design Considerations

**Figure 11-17 (Right)** Elimination of a dry-sand core by a change in part design.



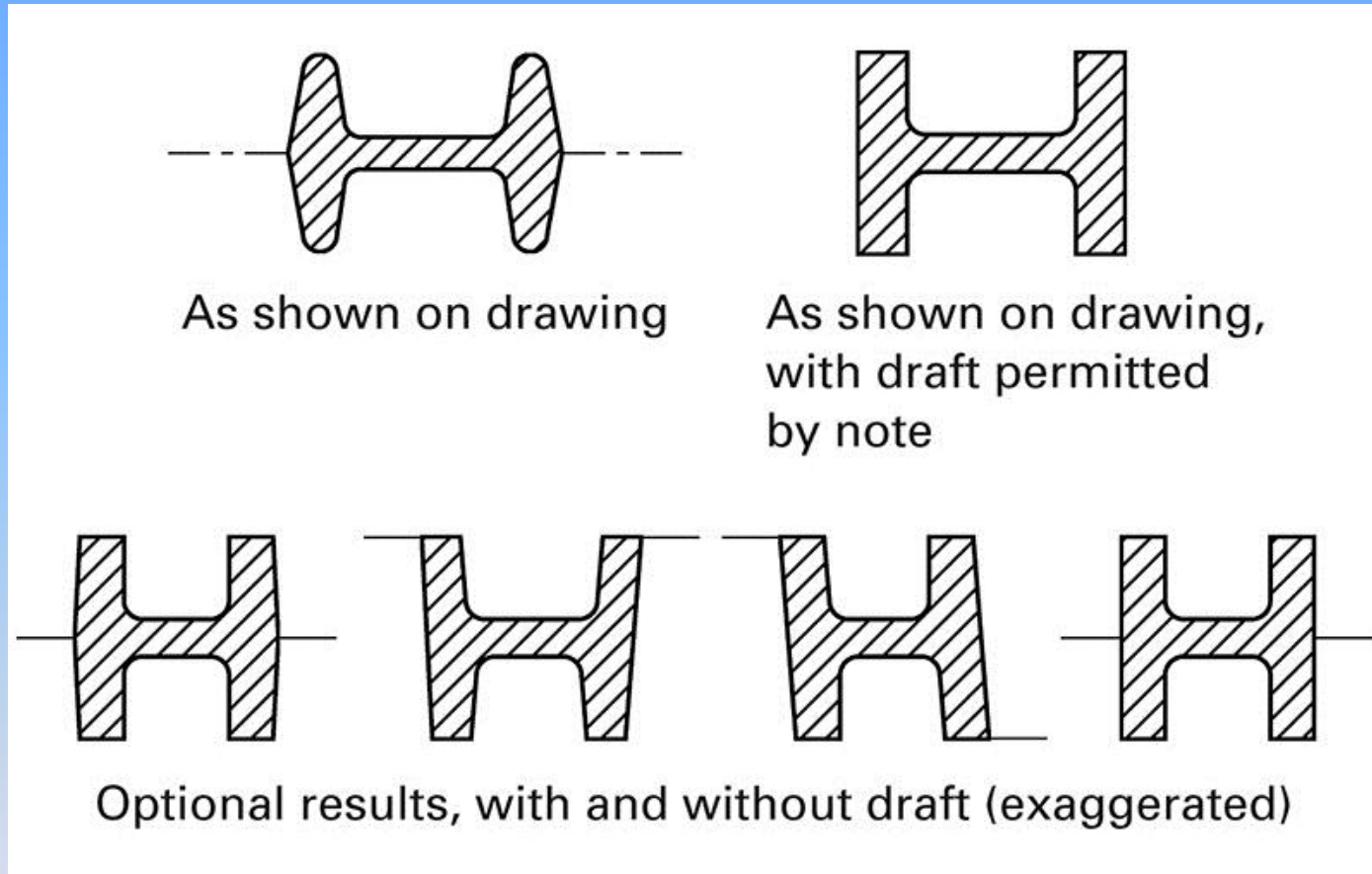
**Figure 11-16 (Left)** Elimination of a core by changing the location or orientation of the parting plane.

# Design Considerations

- It is often desirable to minimize the use of cores
- Controlling the solidification process is important to producing quality castings
- Thicker or heavier sections will cool more slowly, so chills should be used
  - If section thicknesses must change, gradual is better
  - If they are not gradual, stress concentration points can be created
    - Fillets or radii can be used to minimize stress concentration points
    - Risers can also be used

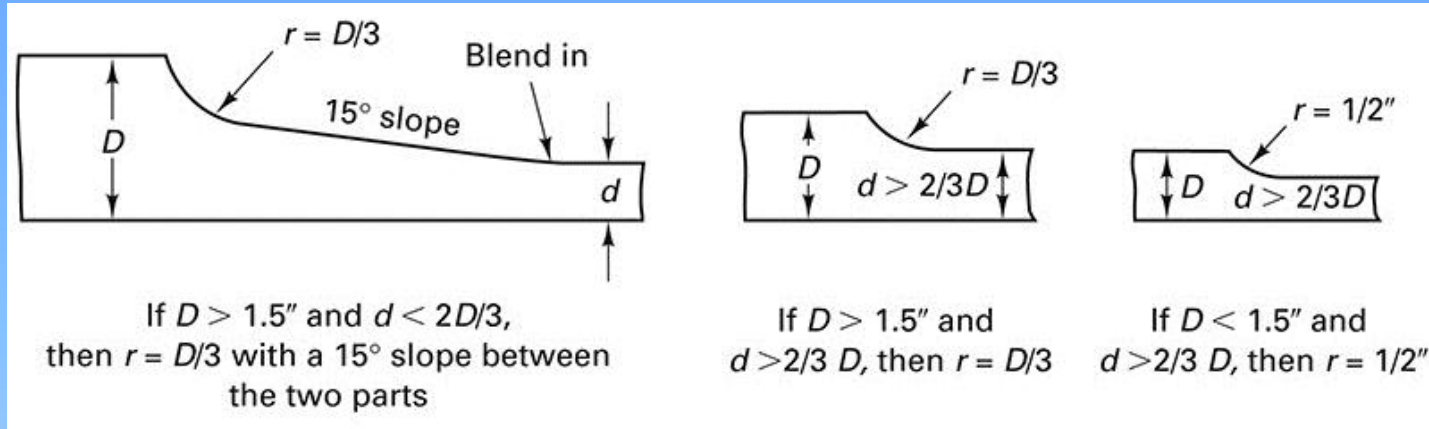


# Parting Line and Drafts

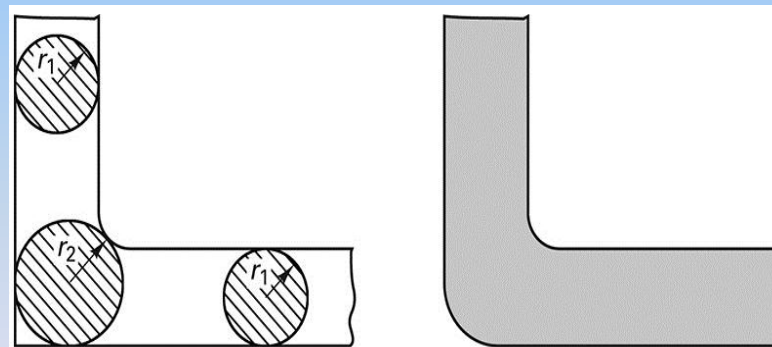


**Figure 11-18** (Top left) Design where the location of the parting plane is specified by the draft. (Top right) Part with draft unspecified. (Bottom) Various options to produce the top-right part, including a no-draft design.

# Section Thicknesses



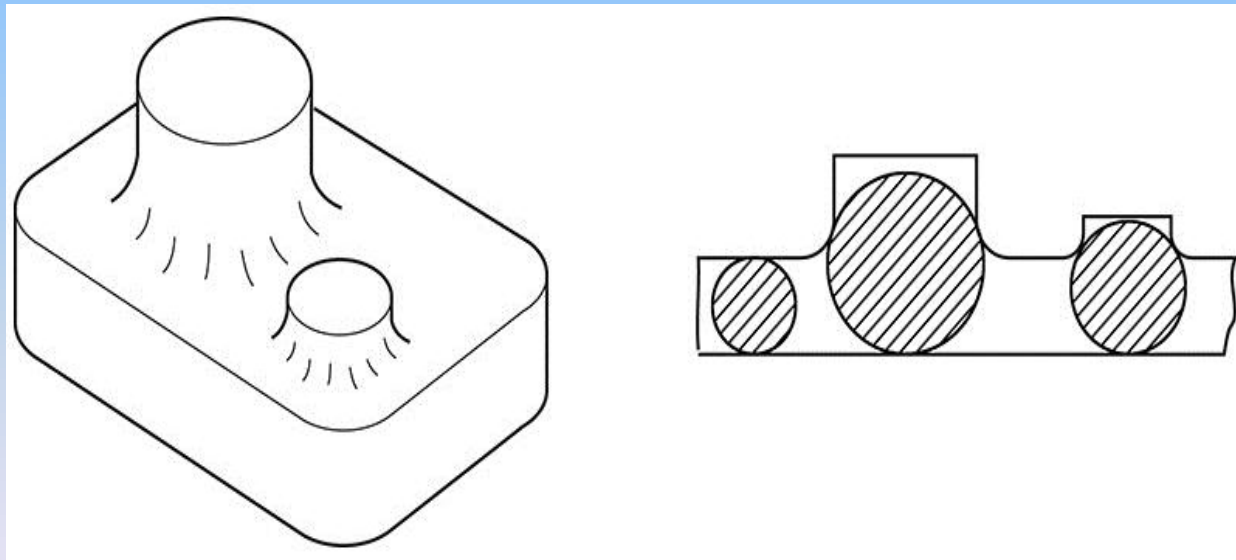
**Figure 11-19** (Above) Typical guidelines for section change transitions in castings.



**Figure 11-20** a) The “hot spot” at section  $r_2$  is caused by intersecting sections. b) An interior fillet and exterior radius lead to more uniform thickness and more uniform cooling.

# Design Modifications

- Hot spots are areas of the material that cool more slowly than other locations
  - Function of part geometry
  - Localized shrinkage may occur

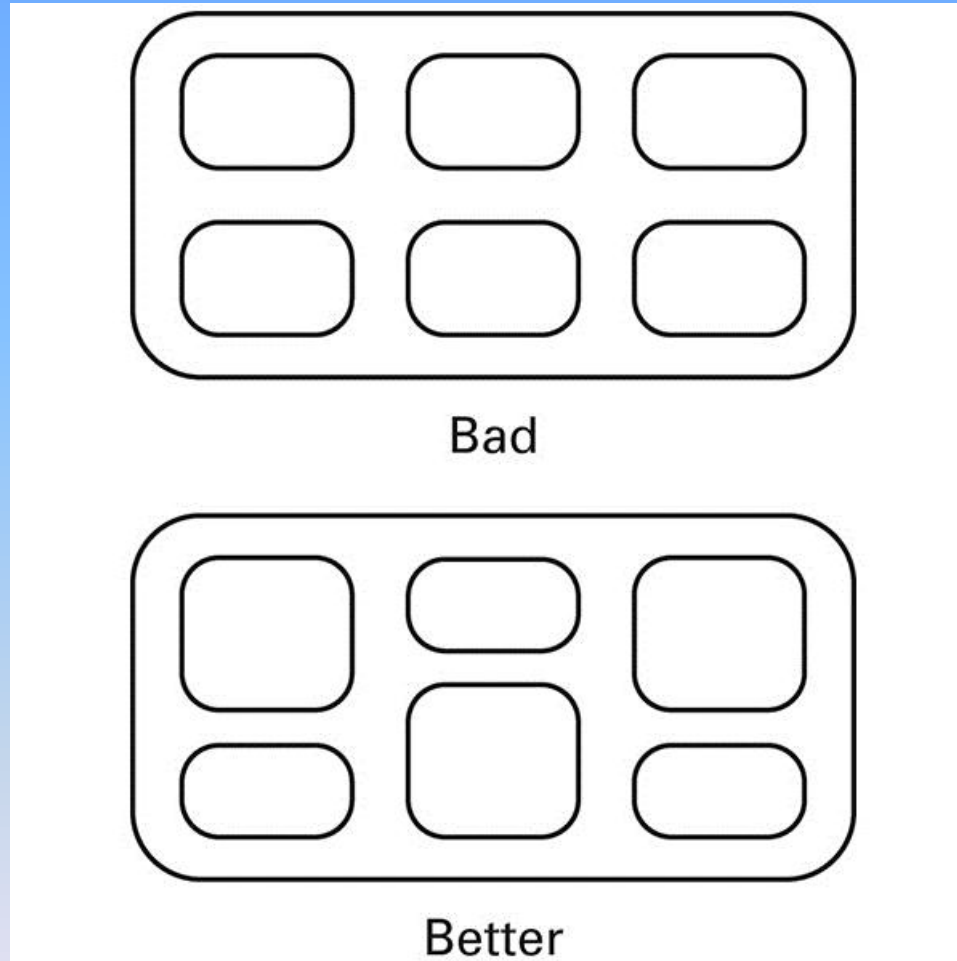


**Figure 11-21** Hot spots often result from intersecting sections of various thickness.

# Design Modifications

- Parts that have ribs may experience cracking due to contraction
  - Ribs may be staggered to prevent cracking
- An excess of material may appear around the parting line
  - The parting line may be moved to improve appearance
- Thin-walled castings should be designed with extra caution to prevent cracking

# Design Modifications



**Figure 11-23** Using staggered ribs to prevent cracking during cooling.

# Casting Designs

- May be aided by computer simulation
- Mold filling may be modeled with fluid flow software
- Heat transfer models can predict solidification

**TABLE 11-3** Typical Minimum Section Thickness for Various Engineering Metals and Casting Processes

Casting Method	Minimum Section Thickness (mm)		
	Aluminum	Magnesium	Steel
Sand casting	3.18	3.96	4.75
Permanent mold	2.36	3.18	—
Die cast	1.57	2.36	—
Investment cast	1.57	1.57	2.36
Plaster mold	2.03	—	—

# 11.7 The Casting Industry

- 14 million pounds of castings are produced every year
- The most common materials cast are gray iron, ductile iron, aluminum alloys, and copper alloys
- 35% of the market is in automotive and light truck manufacturing
- Castings are used in applications ranging from agriculture to railroad equipment and heating and refrigeration

# Summary

- A successful casting requires that every aspect of the process be examined
- Every aspect from the desired grain structure to the desired finish of the product should be considered during design stages
- Efforts should be made to minimize cracking and defects
- There are a variety of processes to improve castings and they should all be considered during the design phase