

ME -215 ENGINEERING MATERIALS AND PROCESSES

Instructor: Veljko Samardzic

Office: MEC325, Tel.: 973-642-7455

E-mail: samardzi@njit.edu

PROPERTIES OF MATERIALS

Chapter 3

Materials Properties

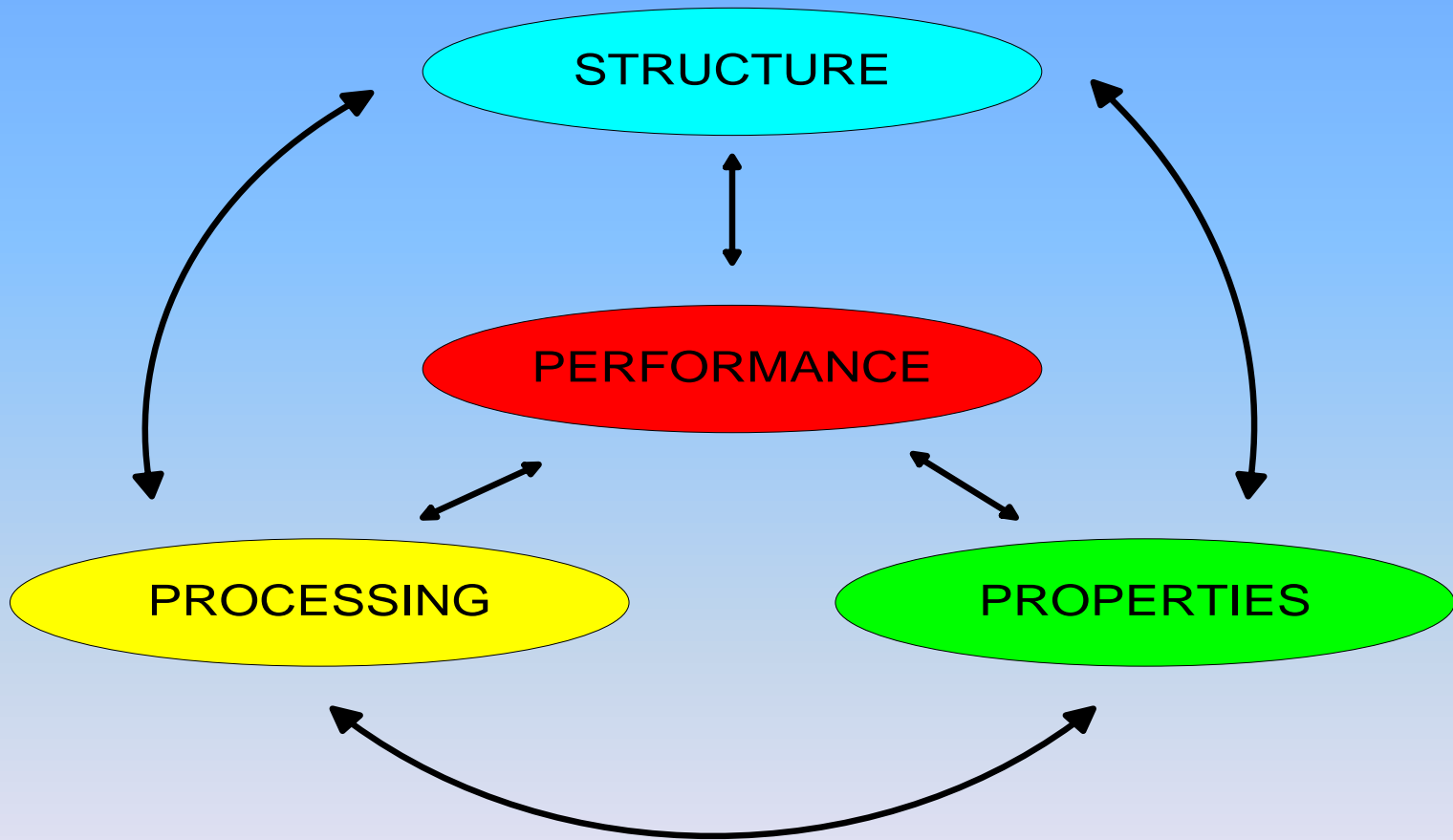

Requirements for Design

- Material requirements must be determined
 - Strength
 - Rigidity
 - Resistance to fracture
 - Ability to withstand vibrations or impacts
 - Weight
 - Electrical properties
 - Appearance
 - Ability to operate under temperature extremes
 - Corrosion resistance

3.1 Metals and Nonmetals

- Engineering materials divided into: **metallic** and **nonmetallic**;
- **Metallic** (**pure**): iron, copper, aluminum, magnesium, nickel, titanium, lead, tin, etc; or **alloys**: steel, bronze, brass, etc. {High strength, luster, good E/T conductivity, luster, high deformability without fracture, high density };
- **Nonmetallic**: concrete, brick, wood, glass, rubber, plastics, composites, etc. (weaker, less ductile, less dense)

3.1 Metallic and Nonmetallic Materials

- Metals have historically been the more important of the two groups
- Recently, advanced ceramics, composite materials, and engineered plastics have become increasingly important
- If both a metal and nonmetal are capable for a certain product, cost is often the deciding factor
- Other factors that are considered:
 - Product lifetime
 - Environmental impact
 - Energy requirements
 - Recyclability

3.1 Properties of Materials

- **Physical properties** are very important in material selection: density (weight), melting point, optical properties (color, transparency, opaqueness), thermal properties (specific heat, coefficient of thermal expansion, thermal conductivity), electrical conductivity and magnetic properties;
- **Mechanical properties** describe response of material to applied forces or loads. Determined by standard laboratory tests. Testing methodology is crucial.
- **Static and dynamic** properties.

3.1 Stress and Strain

- Stress is the force or the load being transmitted through the material's cross sectional area
- Strain is the distortion or deformation of a material from a force or a load
- Stress and strain can occur as tensile, compressive or shear

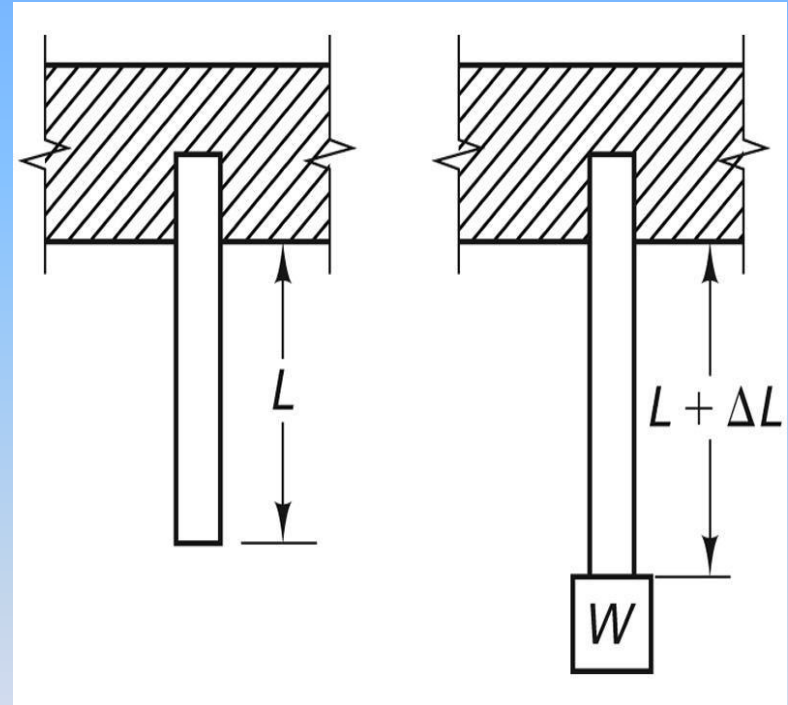
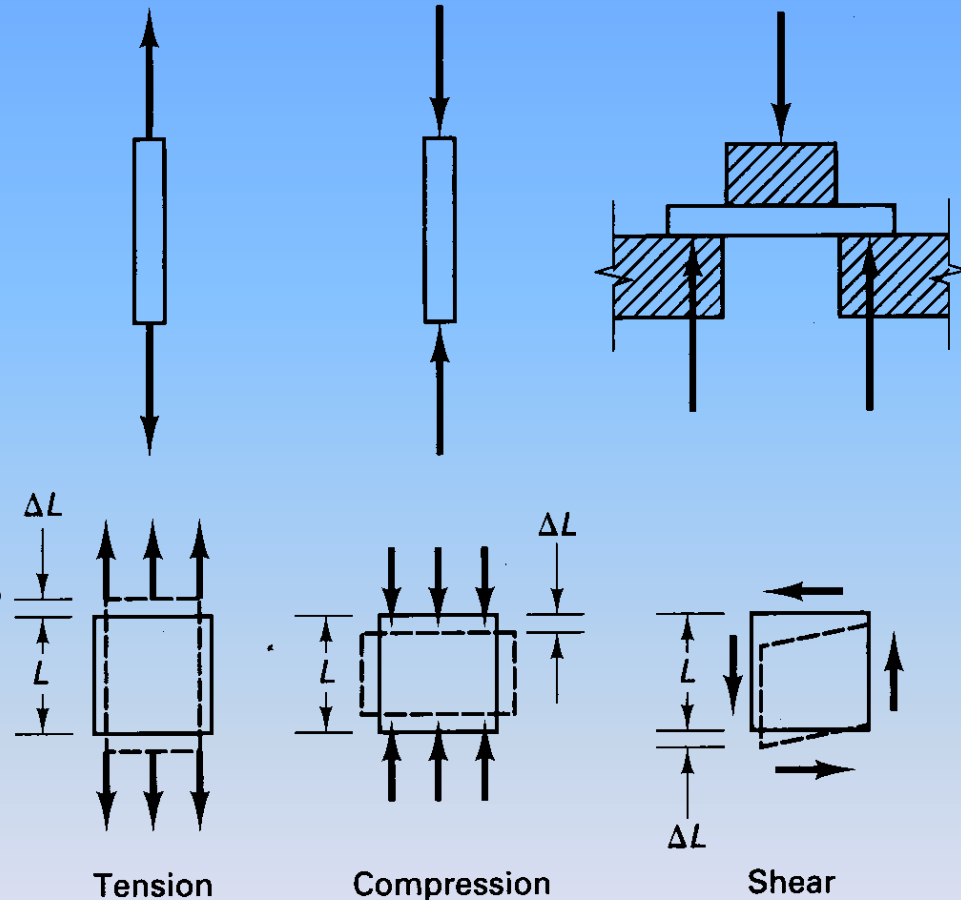

Figure 2-2 Tension loading and the resultant elongation.

3.2 Types of Stress

- By definition it is force divided by cross-sectional area transmitting the load:
$$S = \frac{F}{A}, \text{ N/m}^2, \text{ MPa}, \text{ lb/in}^2$$
- Types of stress: normal (tension or compression), shear, hydrostatic pressure;
- Engineering stress;
- True stress.



3.2 Static Properties

- If loads applied on the material do not vary or vary negligibly they are **static loads**.
- **Static properties** determined by standardized tests under static loads;
- A number of tests have been developed to determine these static properties of materials

3.2 Standard Tensile Specimens

- Round

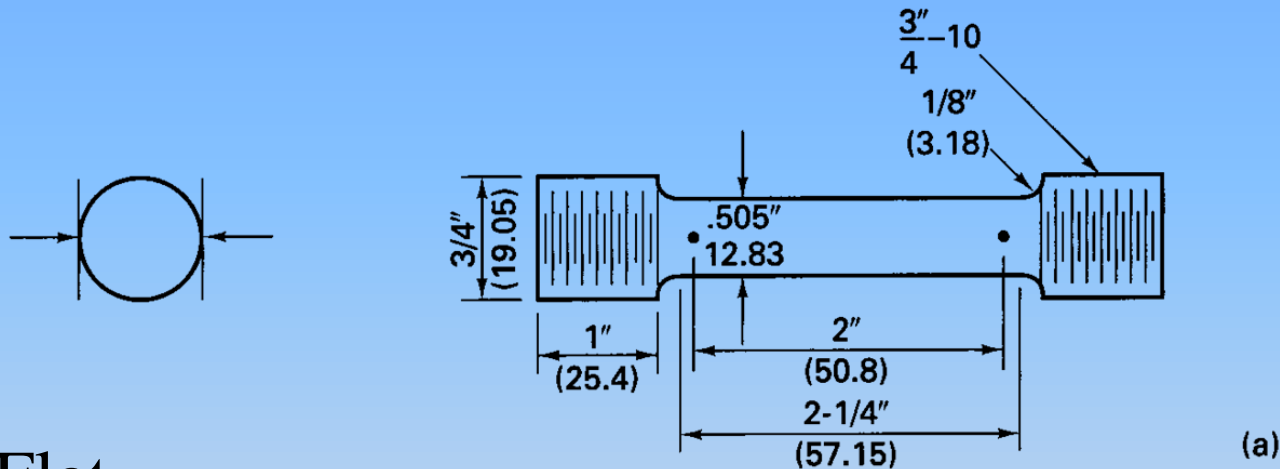

- Flat

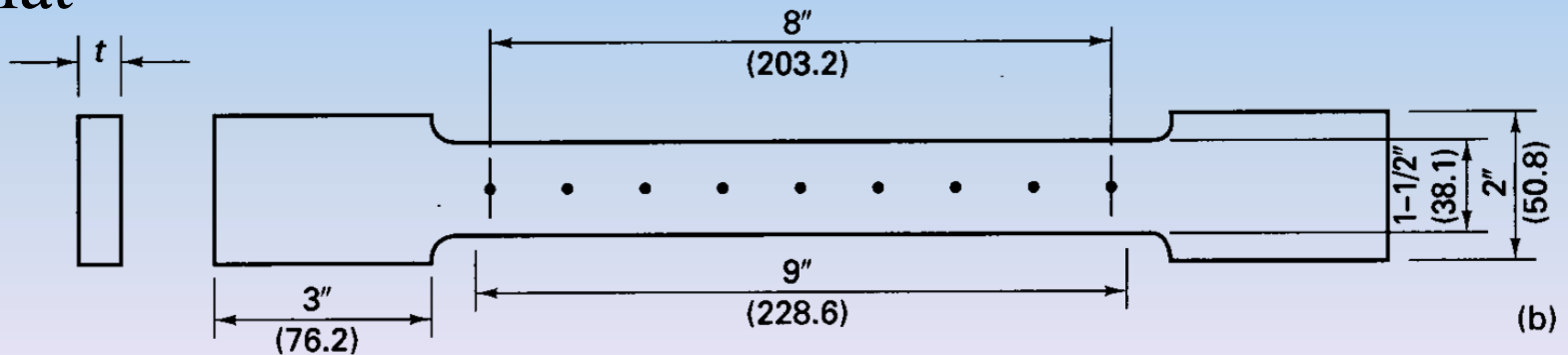

Necked Region of Tensile Specimen

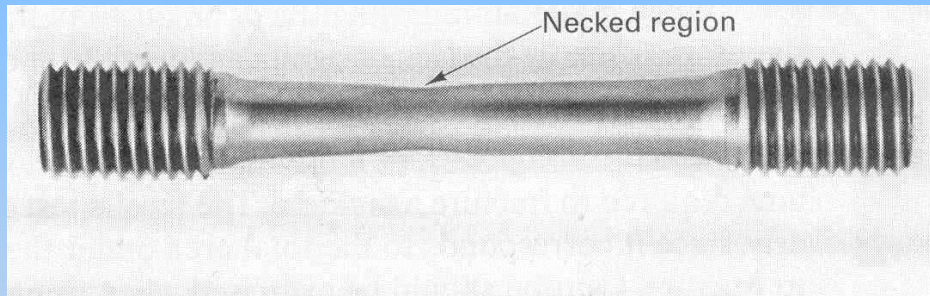

3.2 Uniaxial Tensile Test

- A standard specimen loaded in tension in testing machine;
- Test parameters: load (F), elongation (gage length) are monitored;
- By standardized test procedures data sets characteristic for specific materials are generated.

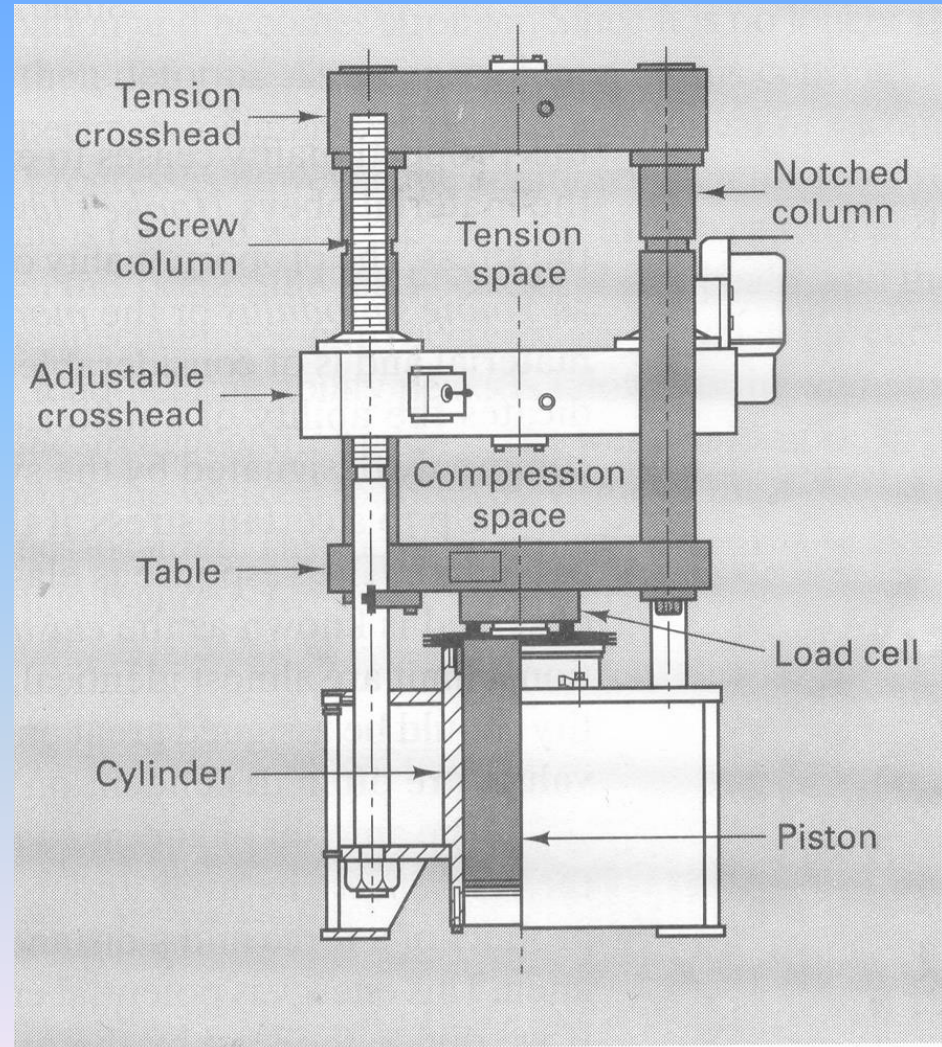

3.2 Tensile Testers



- Twin column (left) and single column (right) motorized tensile strength testers

3.2 Engineering Stress-Strain Diagram for Low Carbon Steel

- Engineering Stress: the load divided by original cross-section area and elongation divided by original gage length to eliminate size effect.

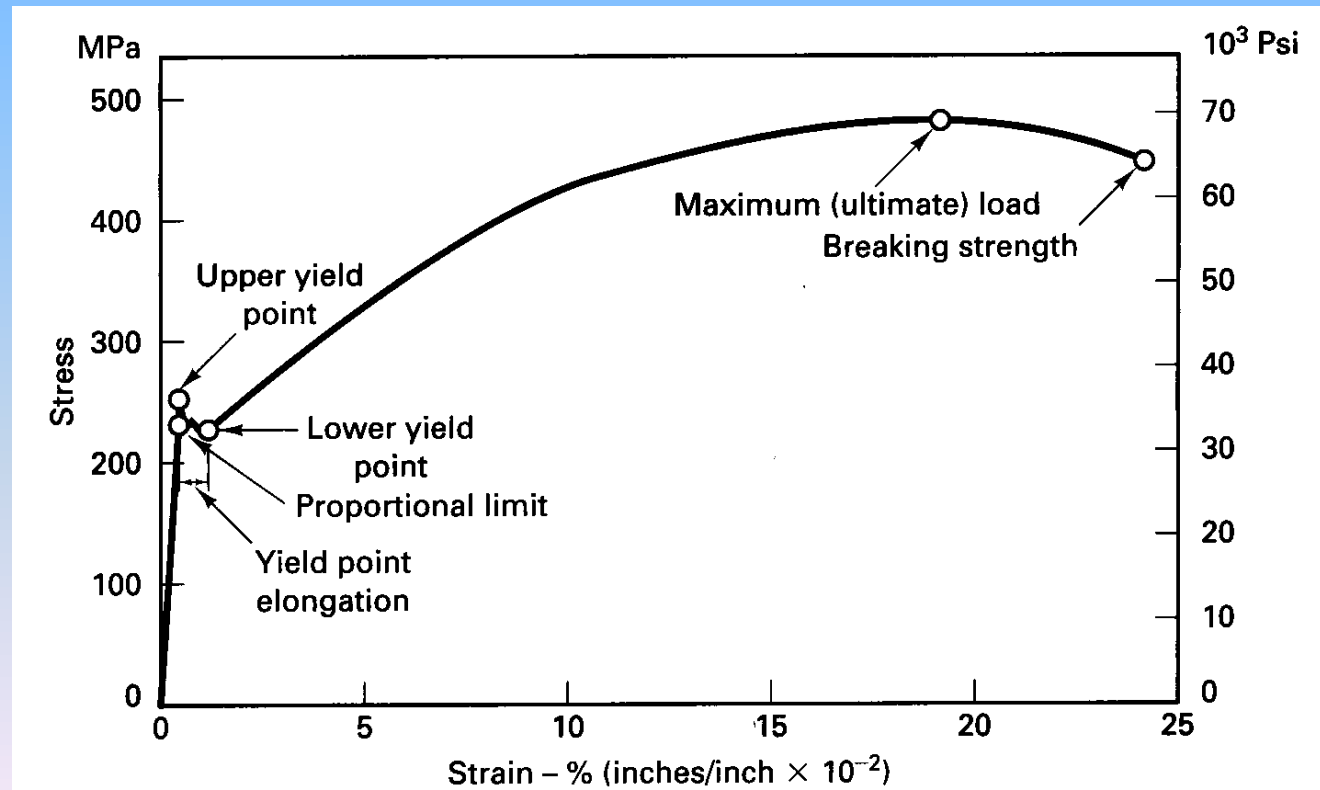

Properties Determined by Stress-Strain Curve

- Engineering stress-strain diagram
- Proportionality limits (Hooke's law)
- Elastic limit
- Young's modulus (E)
- Measure of Stiffness
- Resilience
- Yield point, upper and lower
- Maximal load
- Breaking stress

Additional Properties Determined by Stress-Strain Curve

- Modulus of resilience-amount of energy per unit volume that a material can absorb
- Plastic deformation-permanent change in shape due to a load that exceeded the elastic limit
- Yield point-stress value where additional strain occurs without an increase in stress
- Offset yield strength-the stress required to produce an allowable amount of permanent strain

3.2 Engineering Stress-Strain Characteristics

- By **Hooke's law** strain is directly proportional to the stress.
- **Proportional limit**: initial response is linear (up to elasticity limit stress and strain are proportional)
- **Young's modulus** (modulus of elasticity) E , defined as ratio of stress and strain in this region.
- **Elastic limit**: for almost all materials almost the same as proportionality limit (for some slightly higher than proportionality limit)

3.2 No Well Defined Yield Point

- **Yield point**: beyond elastic limit no proportionality between stress and strain.
- Upper yield point (for low C steels);
- Lower yield point (for low C steels);
- Not well defined;
- **Ultimate strength** (maximum load);
- **Failure** (breaking or fracture strength);

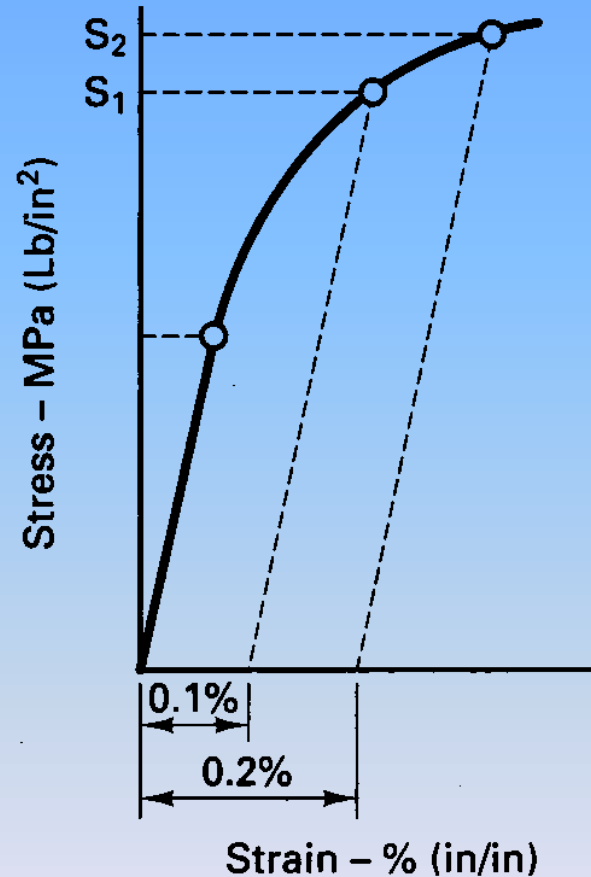

Toughness

- Toughness: work per unit volume to fracture a material.
- Total area under the stress-strain curve.
- The toughness is the product of yield strength and uniform elongation.

3.2 Ductility and Brittleness

- **Ductility** : the degree of material deformation without the failure (rubber, metals). Evaluated by **percent elongation** (% E.L.) prior to necking area and **percent reduction in area** (% R.A.).

$$R.A. = \frac{A_o - A_f}{A_o} \cdot 100\%$$

- % R.A.=0% (brittle) to 100%(extr. plastic)

- **Brittleness**: if material fails with little or no ductility (concrete, chalk).

Ductility and Brittleness

- Necking is a localized reduction in cross sectional area
- For ductile materials, necking occurs before fracture
- For brittle materials, fracture ends the stress strain curve before necking
- Percent elongation is the percent change of a material at fracture
- Material failure is the onset of localized deformation or necking

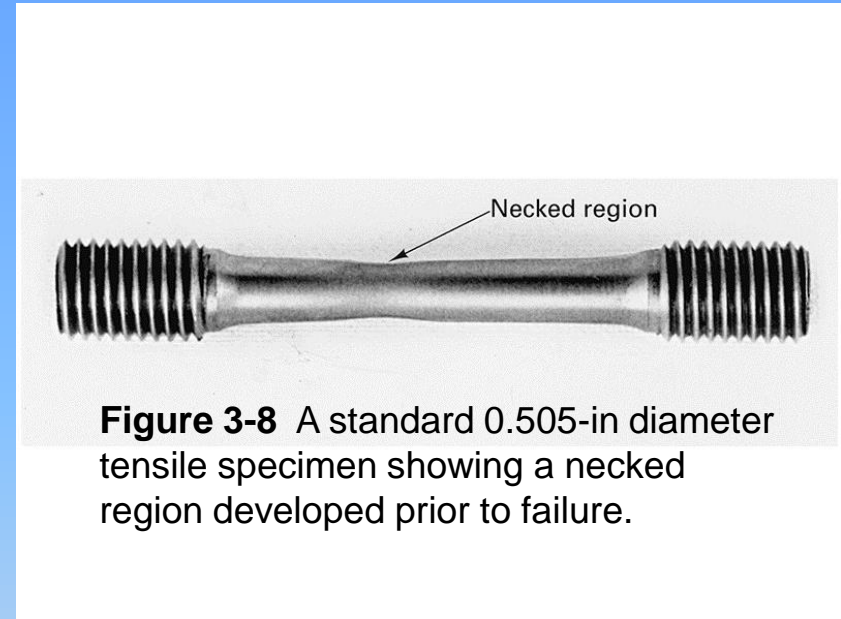

Percent Reduction in Area:

$$R.A. = \frac{A_0 - A_f}{A_0} \times 100\%$$

3.2 Engineering vs. True Stress

- Engineering stress: $s = \frac{F}{A_0}$, is calculated in respect to initial cross-section area.
- True stress: $\sigma = \frac{F}{A}$, is calculated in respect to actual area as it changes during the deformation process.
- These stresses do not differ significantly for small deformations.

3.2 True Stress-True Strain Curves

- True, natural or logarithmic strain:

$$\varepsilon = \int_{L_0}^L \frac{dl}{l} = \ln \frac{L}{L_0} = 2 \ln \frac{D_0}{D}$$

- For cylindrical specimen:

$$\frac{L}{L_0} = \frac{A_0}{A} = \frac{D_0^2}{D^2}$$

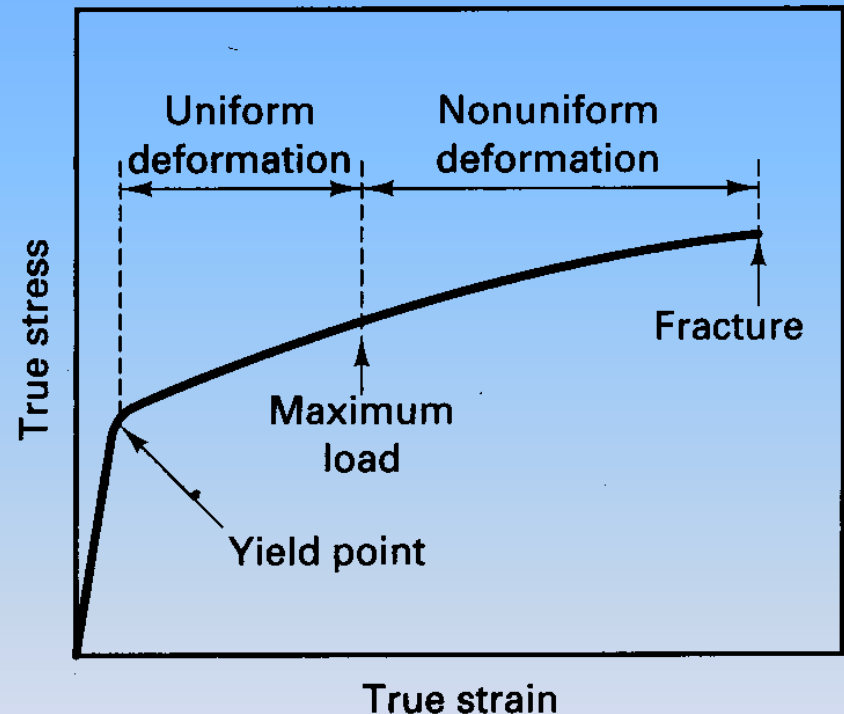

3.2 Engineering vs. True Strain

- Engineering strain: defined as elongation divided by initial gage length: $e = \frac{L_f - L_i}{L_i} = \frac{\Delta L}{L}$

- True strain:

$$\varepsilon = \int_{L_0}^L \frac{dl}{l} = \ln \frac{L}{L_0} = 2 \ln \frac{D_0}{D}$$

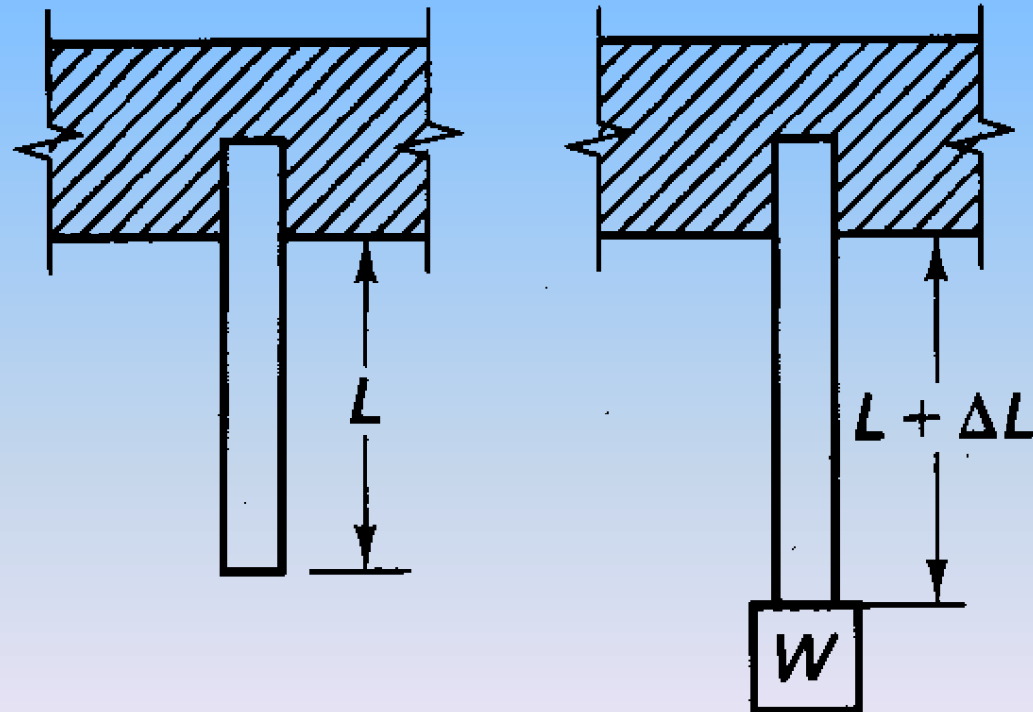

3.2 Strain Hardening

- Loading and unloading within the elastic region will result in cycling up and down the linear portion of the stress strain curve
- When metals are plastically deformed, they become harder and stronger (strain hardening)

3.2 Strain Hardening

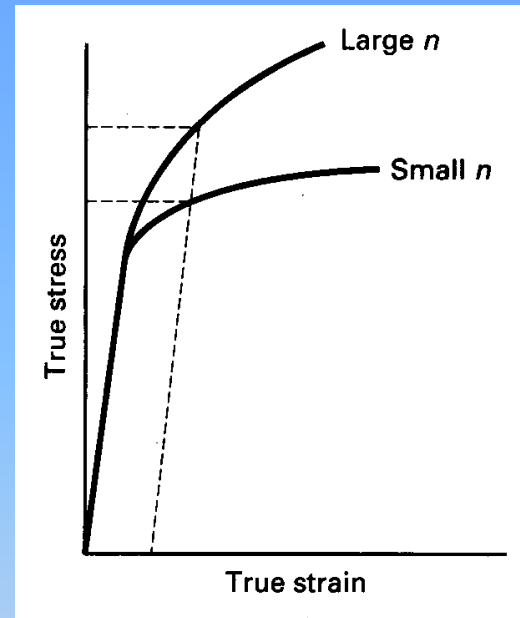
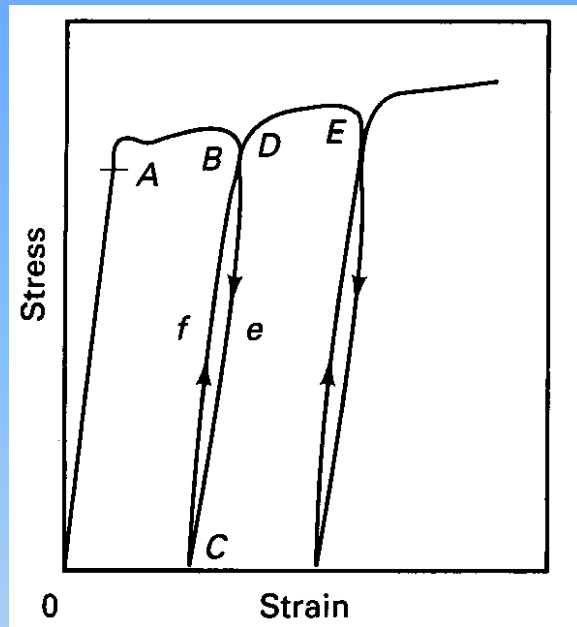

$$\sigma = K\varepsilon^n$$

- Left: stress-strain diagram generated by unloading and reloading of specimen;
- Right: true stress-true strain curves for metals with large and small strain hardening exponent.

More on Static Properties

- **Compression strength**: compression test which is similar to tensile test behavior but more difficult to conduct.
- **Damping capacity**: ability of the material to absorb mechanical vibrations (impact energy) or damp them out quickly.
- **Hardness**: ability of the material to resist to the plastic deformation.

Hardness Testing

- Hardness is the resistance to permanent deformation in the form of penetration or indentation
- Brinell Hardness Test
- Rockwell Test
- Vickers Hardness Test-a diamond pyramid as indenter
- Knoop Microhardness
- Hardness testing can provide a close approximation of tensile strength (~500 times the Brinell hardness number for psi)

Brinell Hardness Testing

- Brinell hardness test: a penetrator (ball of $D=10$ mm) made of tungsten carbide or hardened steel ball of $D=10$ mm;
- Standard load: 500, 1500 or 3000kg;
- Load time : 10 -15 s;
- BHN-Brinell hardness number.

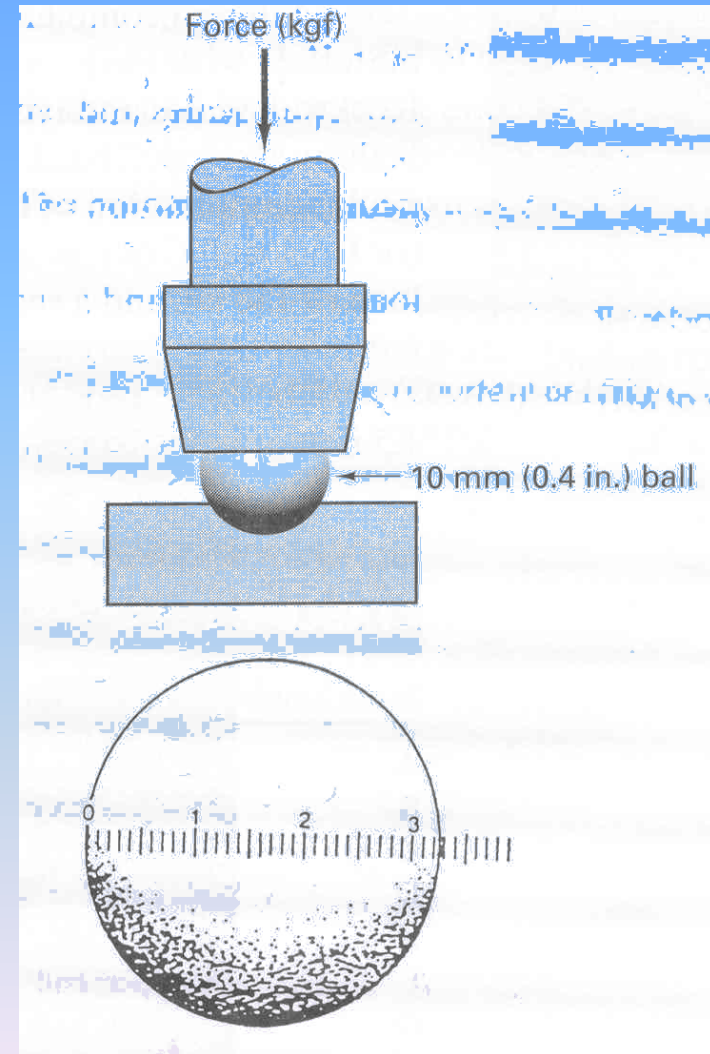

Hardness Vs. Tensile Strength

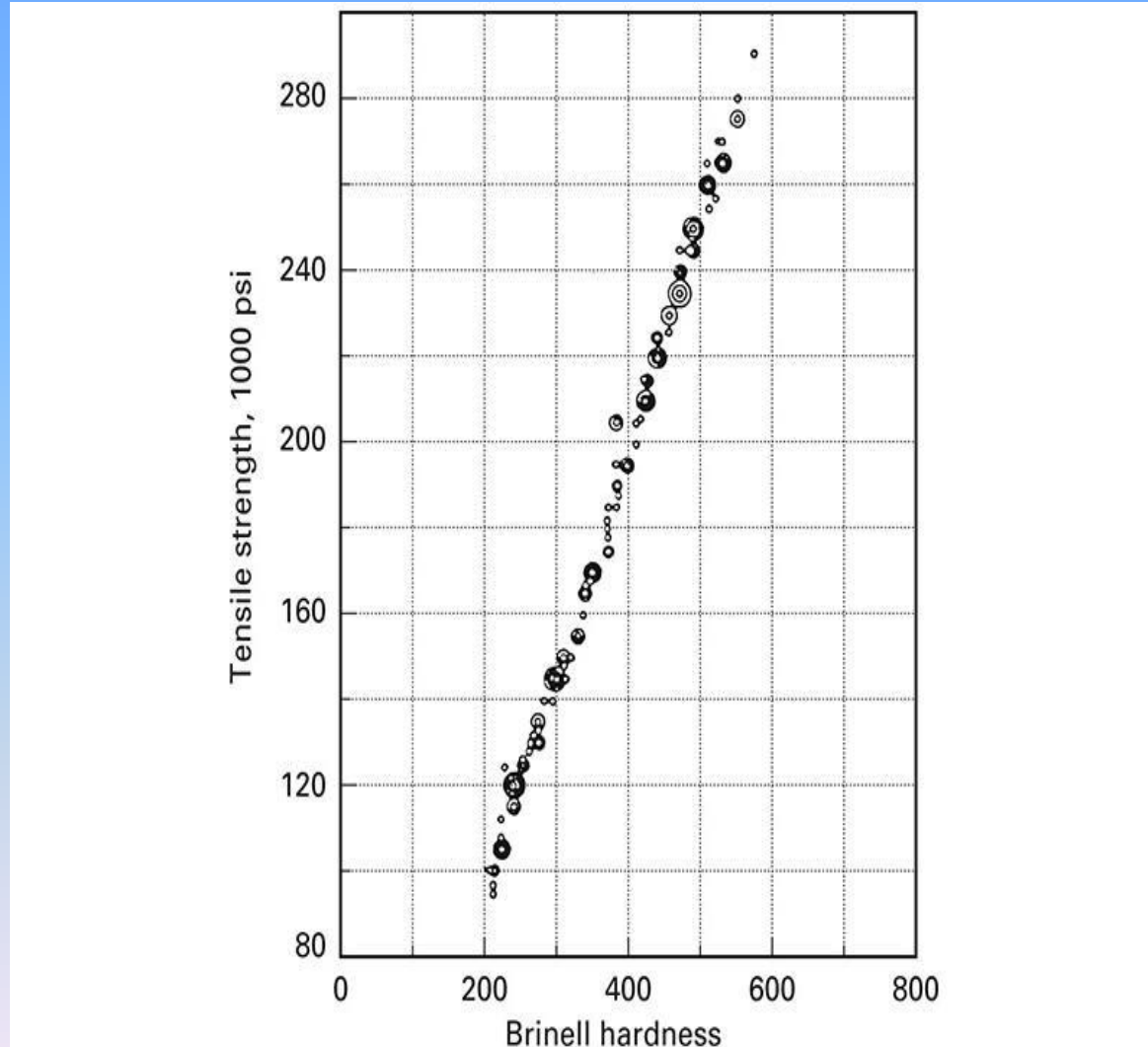

The Rockwell Test

- Penetration performed in two stages (**minor** and **major** load);
- Indenter (small diameter ball or diamond tip);
- Not for thin samples;
- Little or no surface preparation;
- Digital readout tester.

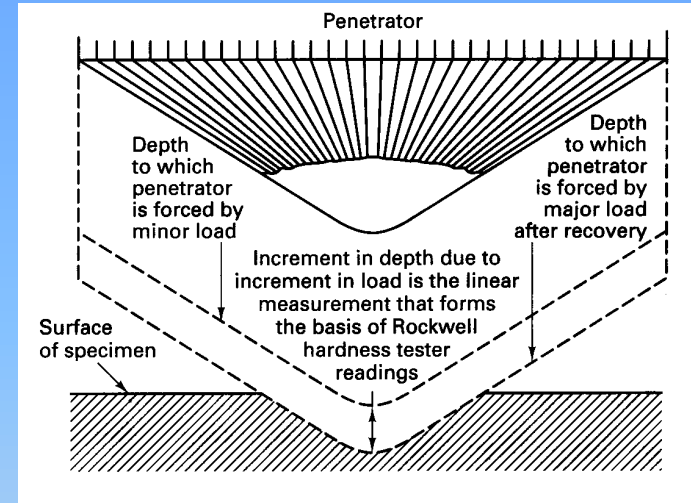

Vickers Hardness Test

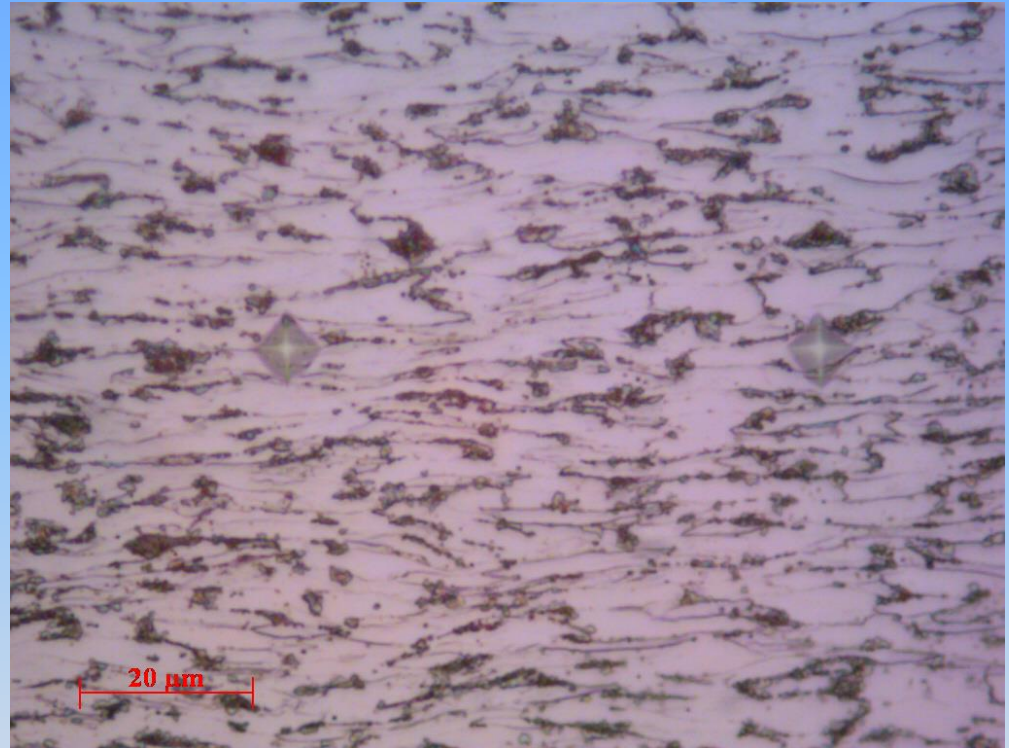
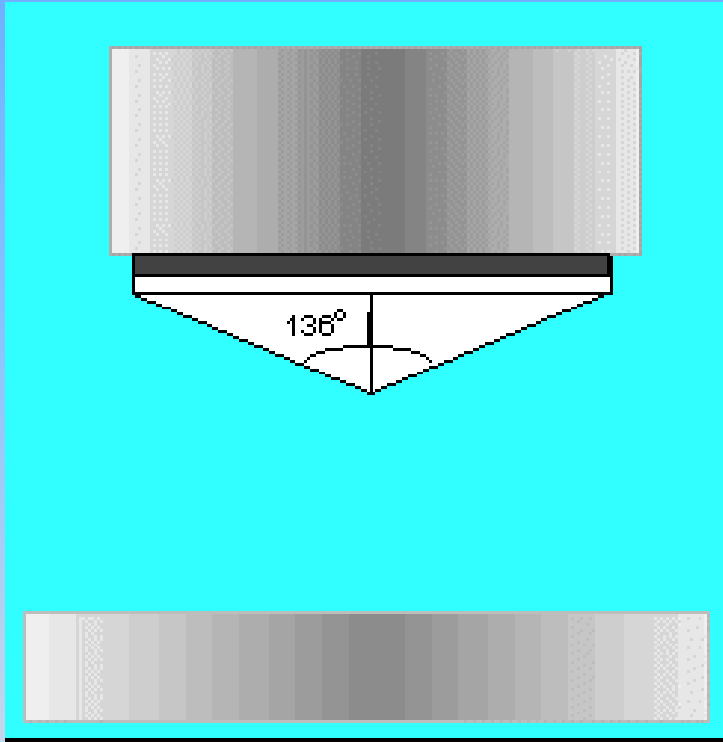

- Simple to conduct. No special preparation. Field testing. High accuracy in determining diamond diagonal. Cheap and reliable.

Microhardness Knoop Test

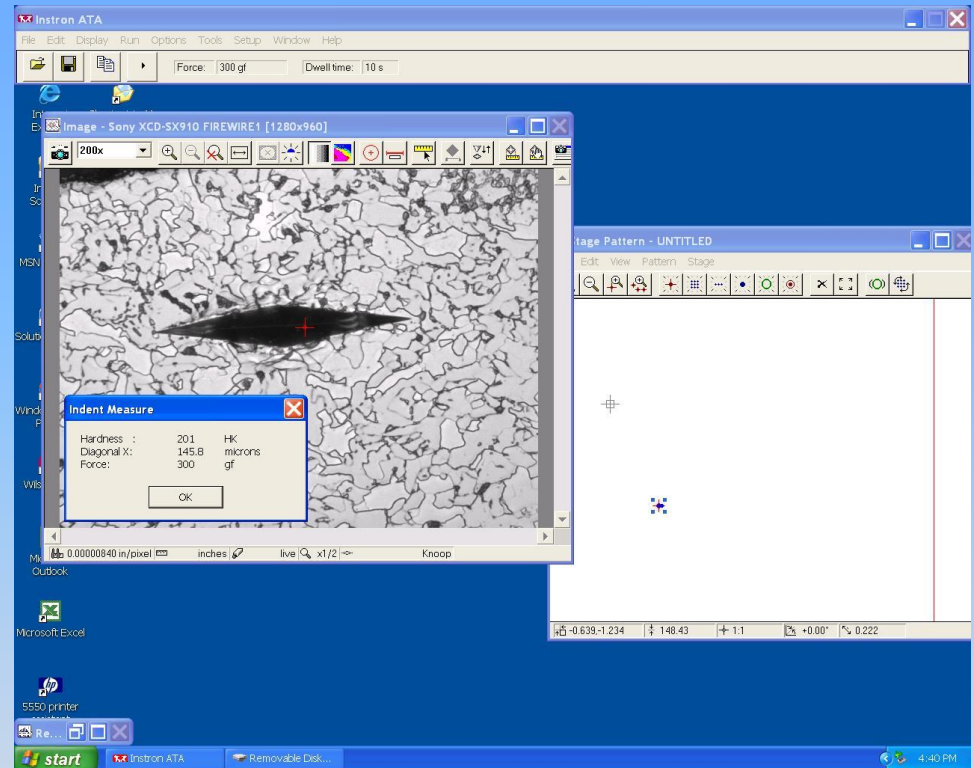
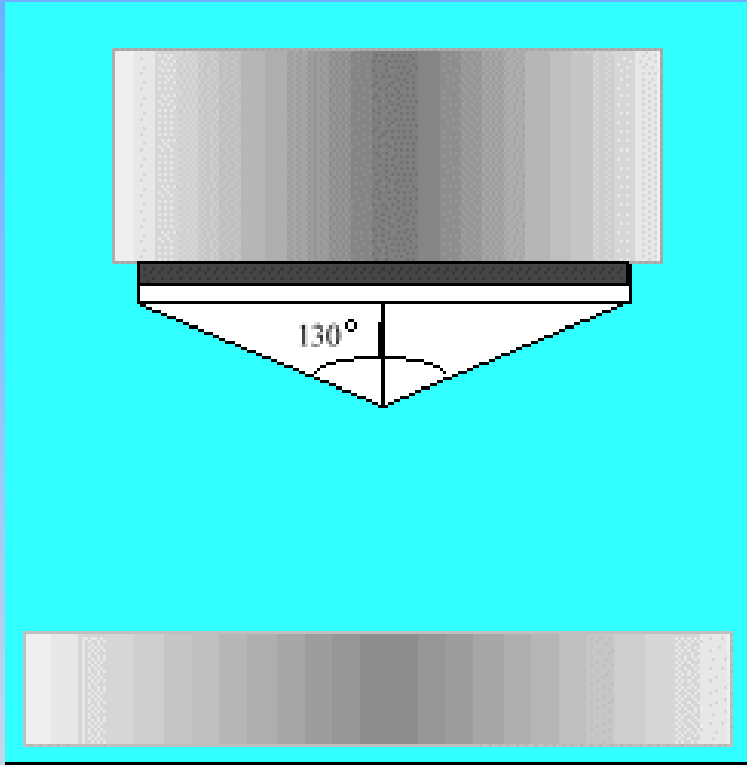

- Very small diamond penetrator exposed to loads between 25 and 3600g. Developed for very precise area hardness evaluation. Very thin samples can be tested.

3.3 Dynamic Properties

- Sudden loads or impacts (rapid varying in magnitude);
- Repeated cycles of loading and unloading;
- Frequent changes in mode of loading (tension to compression);

3.3 Dynamic Properties

- Bending impacts (Charpy and Izod tests)
- Tension impacts
- Fatigue and endurance limit
 - Materials can fail if they are subjected to repeated applications of stress
 - Fatigue is cyclic repetition of a load
 - Stress versus number of cycles curves are useful in determining endurance limits
 - Endurance limit is the stress below which the material will not fail regardless of the number of cycles
 - Fatigue strength is the maximum stress that can be sustained for a number of loading cycles

3.3 Impact Tests

- **Bending impacts**
- Charpy test (impact at the center);
- Izod test (impact at the end);
- Standardized notched specimen;
- **Tension impacts**

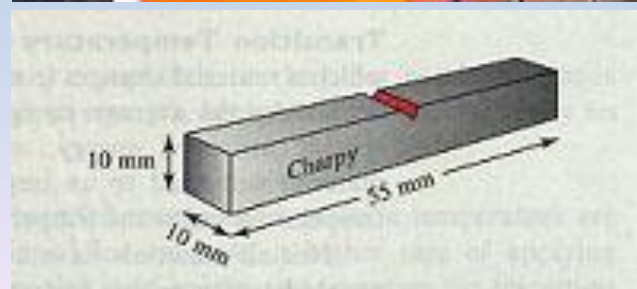

Impact Test Specimens

- Standard notched specimen;
- Notched and un-notched specimen before and after testing.

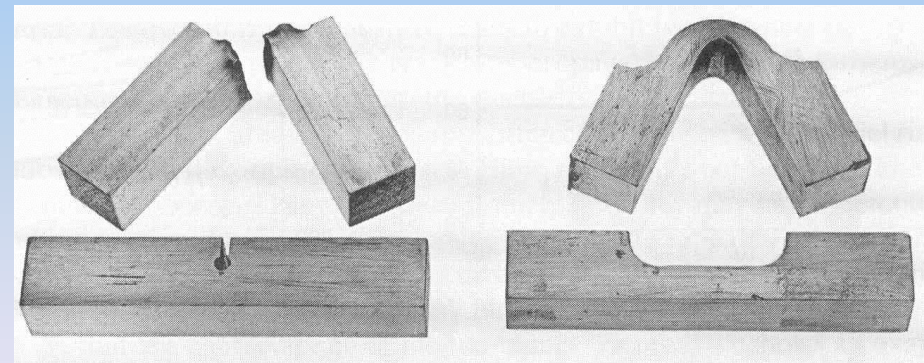
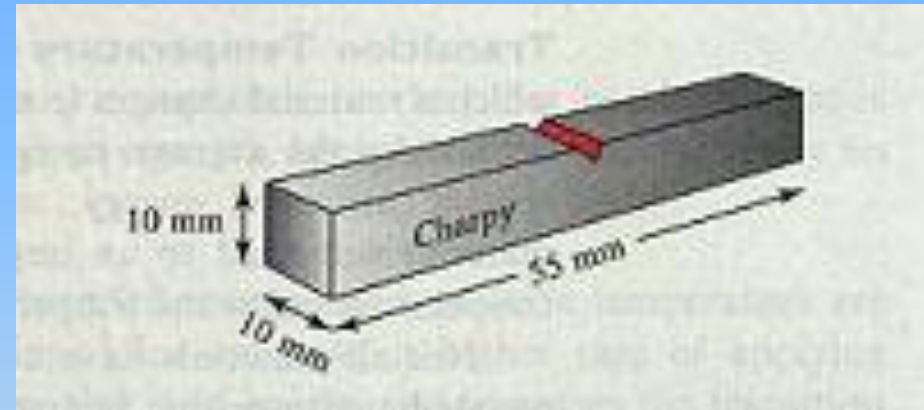

Izod Specimen

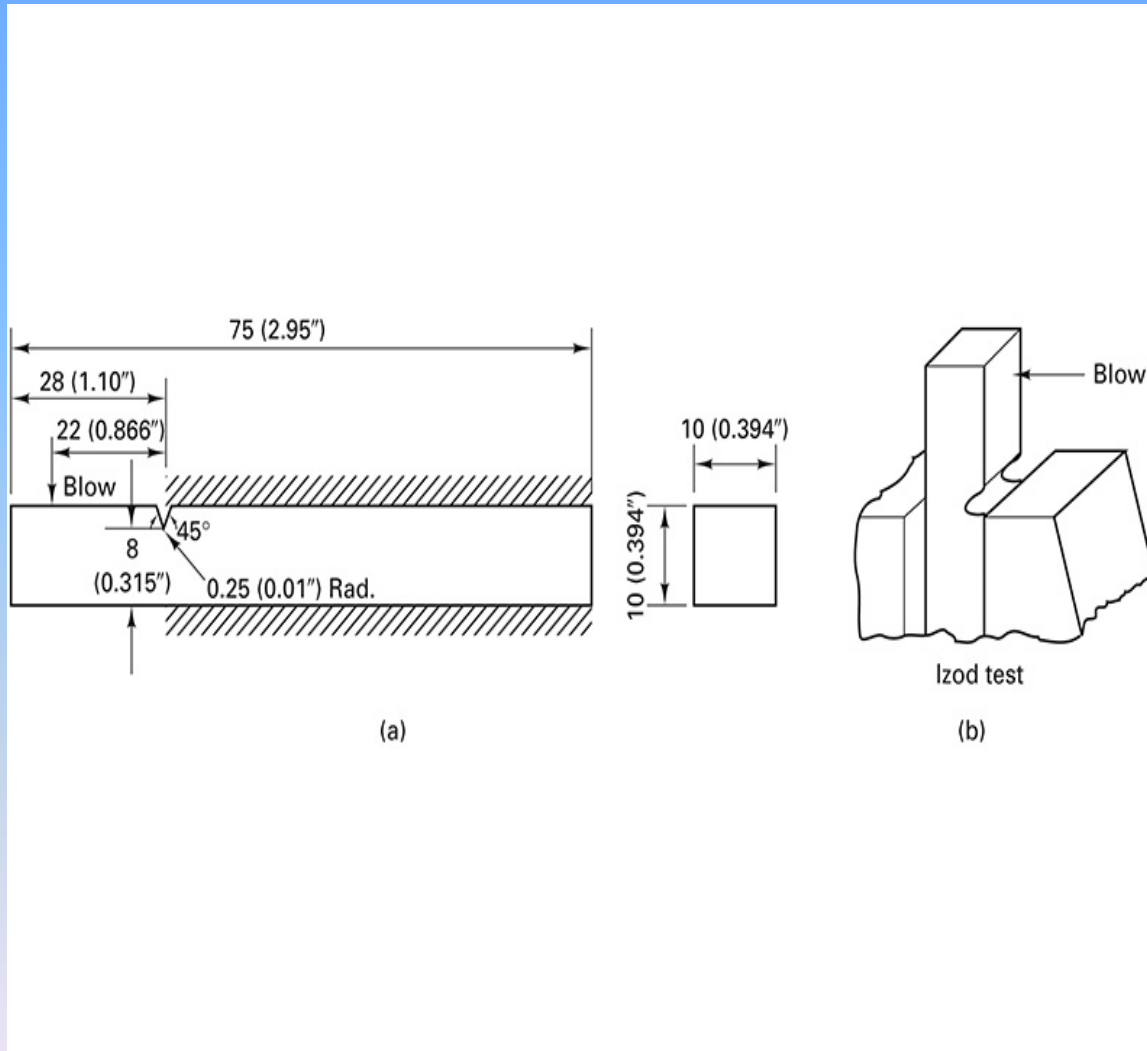

Charpy Specimen

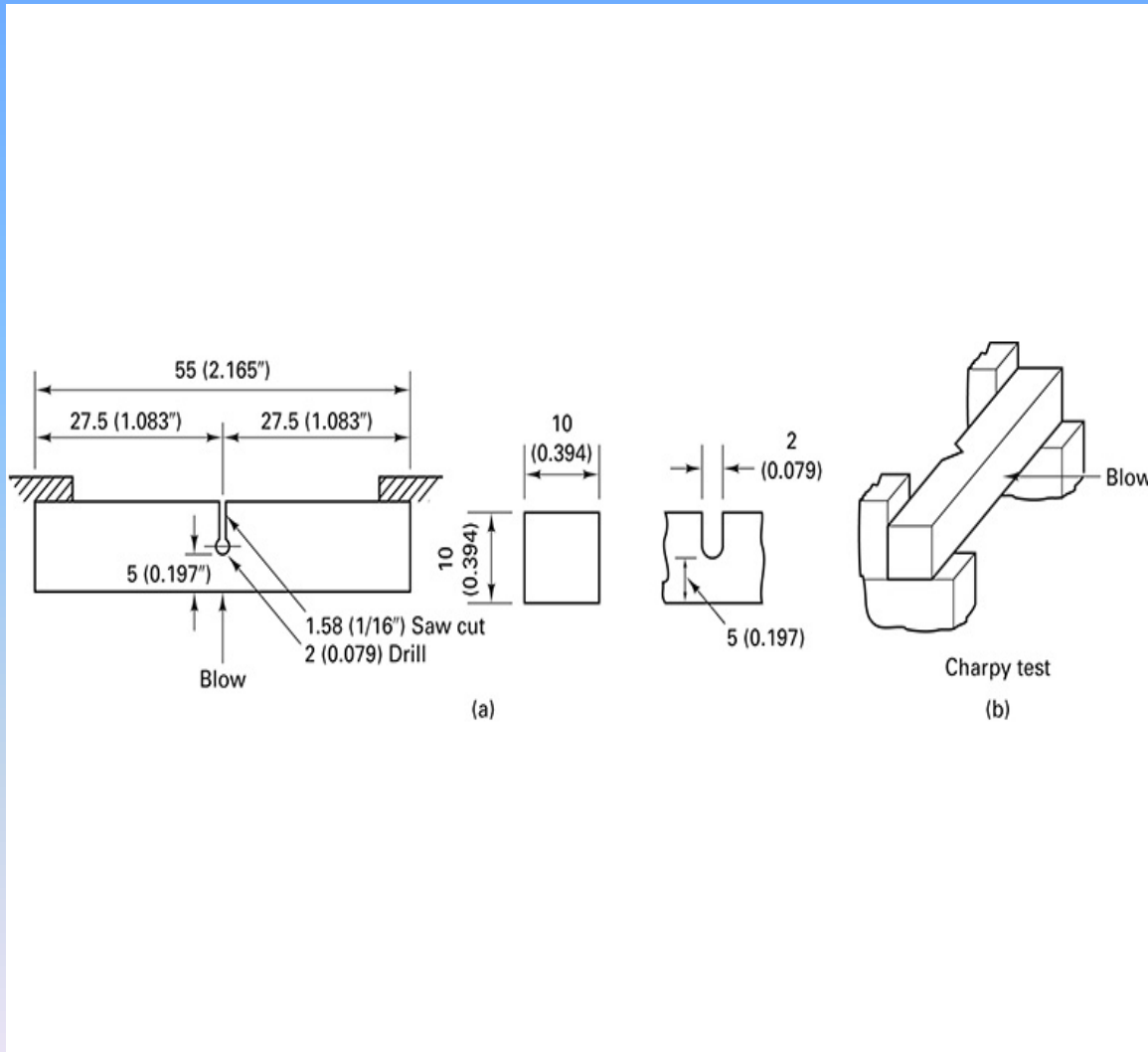

3.3 Fatigue and Endurance Limit

- **Fatigue**: components fail at less than ultimate tensile strength, and usually less than yield strength at cyclic loads.
- **Endurance limit (strength)**: stress below which material is safe from failing due cyclic load (S-N curve).
- Fatigue depends on stress raisers (sharp corners, surface cracks, machining marks, etc.)
- Existence of surface cracks or flaws reduces time of crack initiation and propagation.

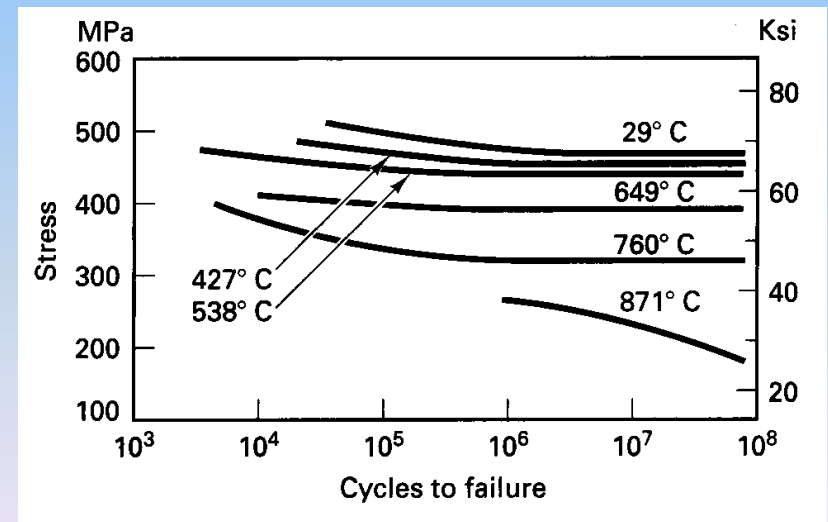
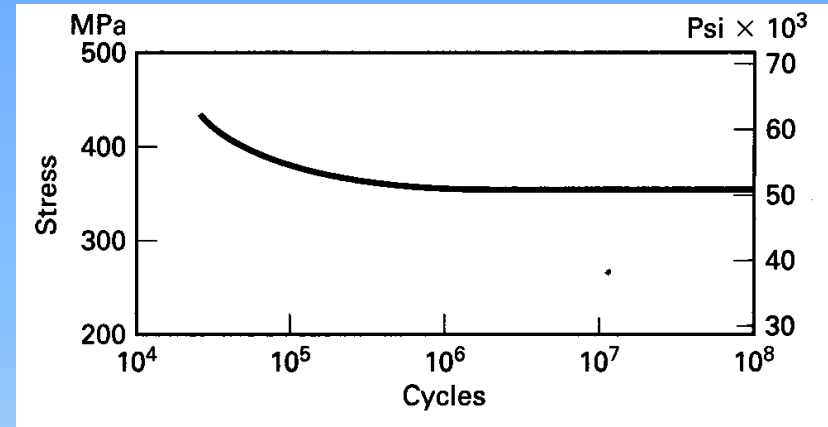

3.4 Fatigue Stress at Various Temperatures

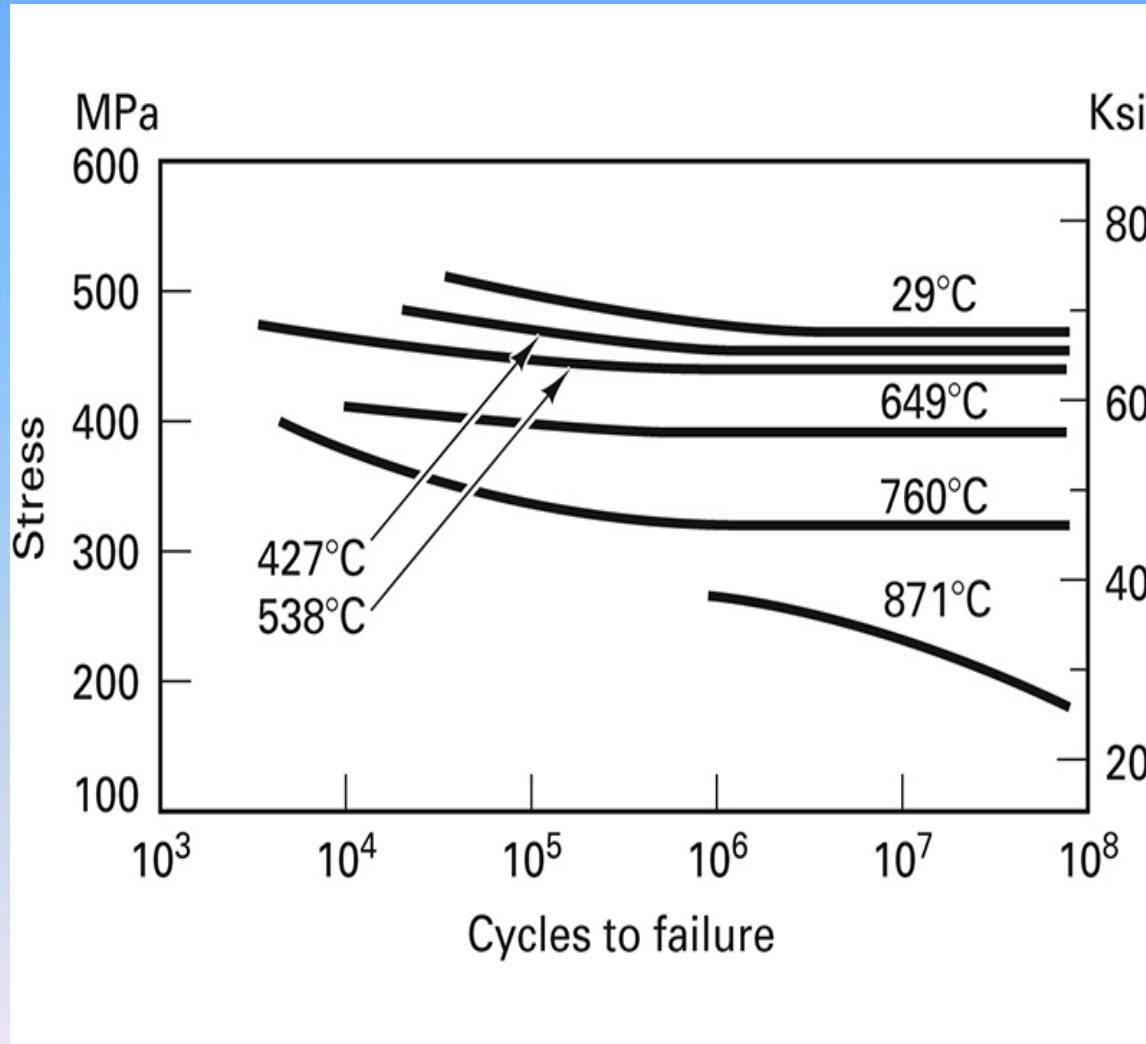

3.4 Temperature Effects

- Temperatures effect the mechanical properties of materials
- Ductile-brittle transition temperature is the temperature at which the response of the material goes from high energy absorption to low energy absorption
- Creep is failure of a material due to long term exposure to elevated temperature

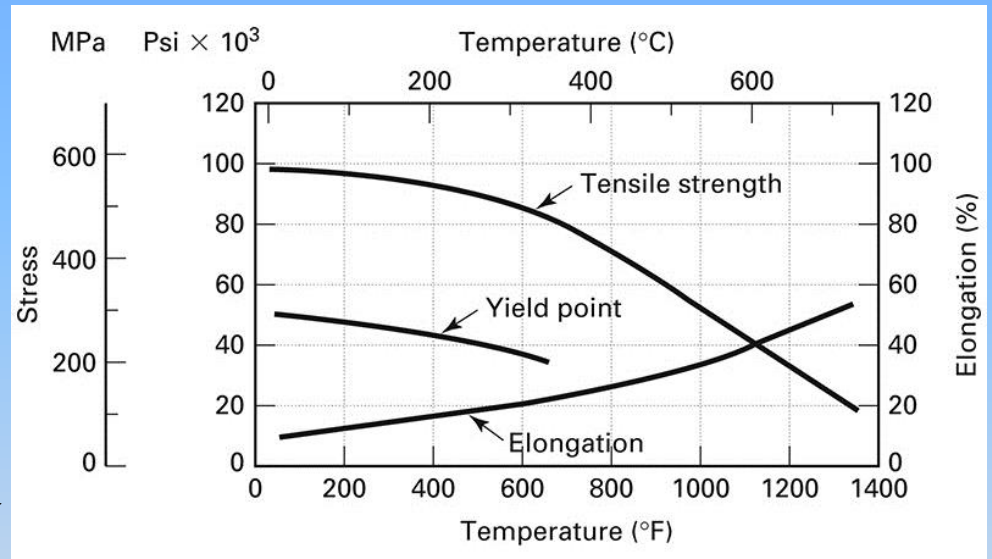
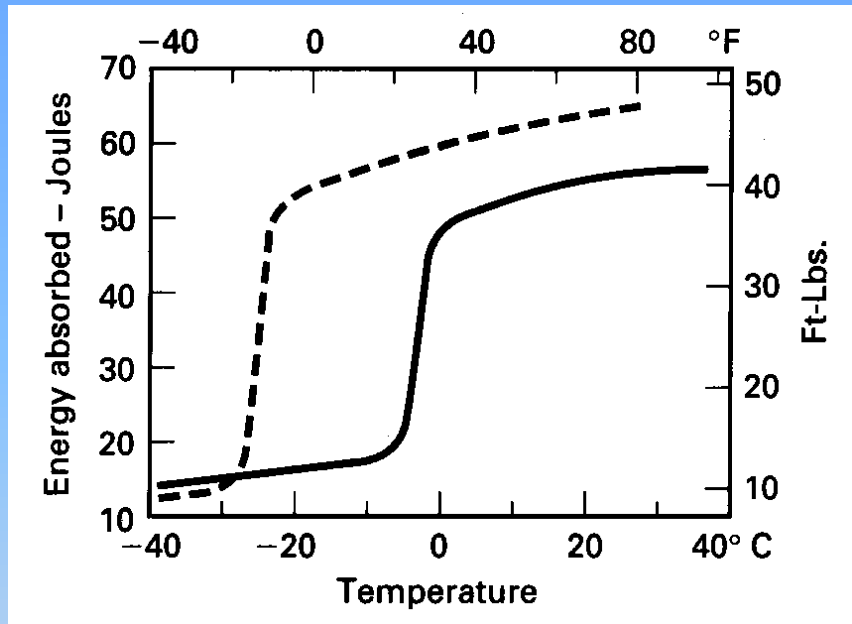
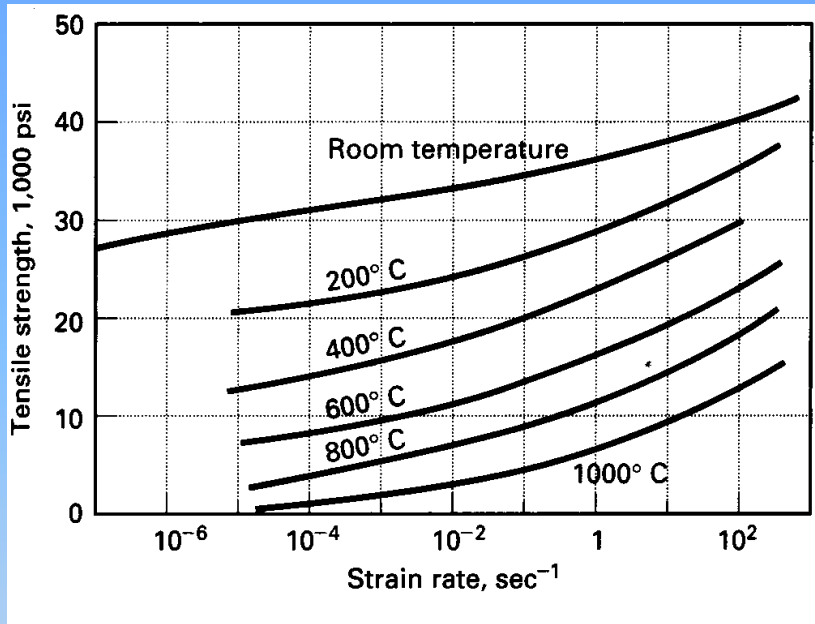

Figure 3-30 The effects of temperature on the tensile properties of a medium-carbon steel.

3.4 Temperature Effect



- Effect of temperature and strain rate on the tensile strength of copper (left).
- Effect of temperature on the impact properties of two low-carbon steels (right).

3.4 Temperature Effect

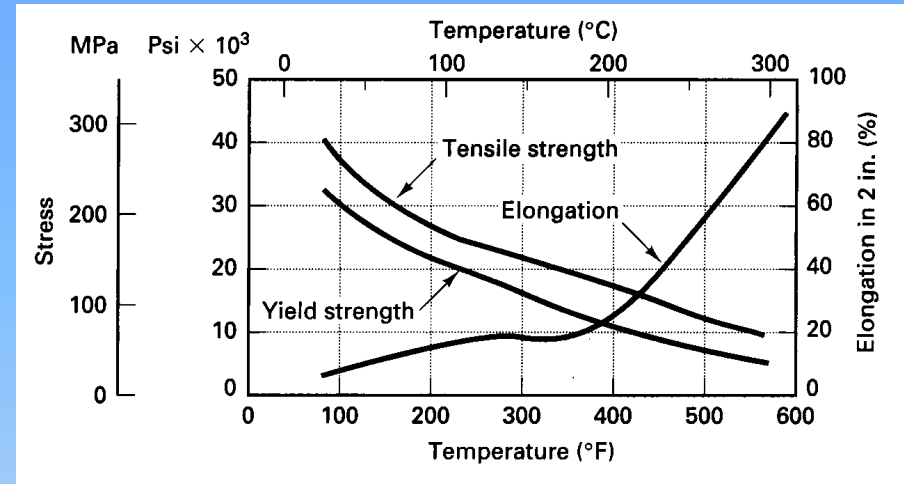
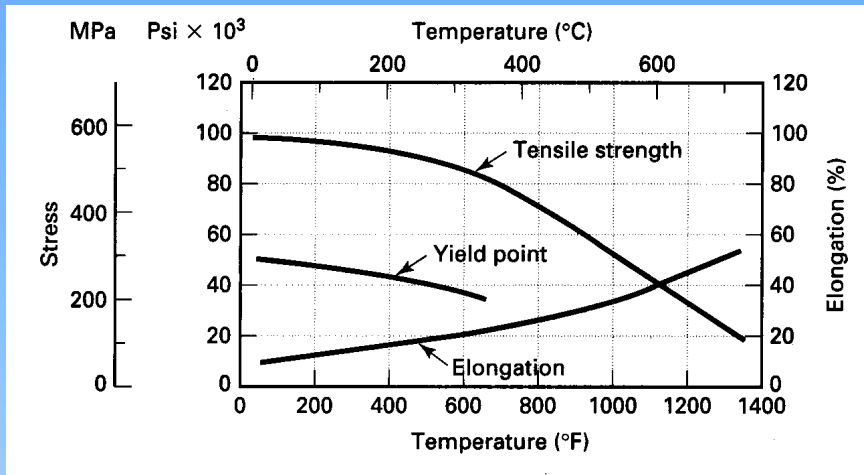

- Effects of temperature on the tensile properties of medium carbon steel (left)
- Effect of temperature on tensile properties of magnesium (right).

Creep Curve

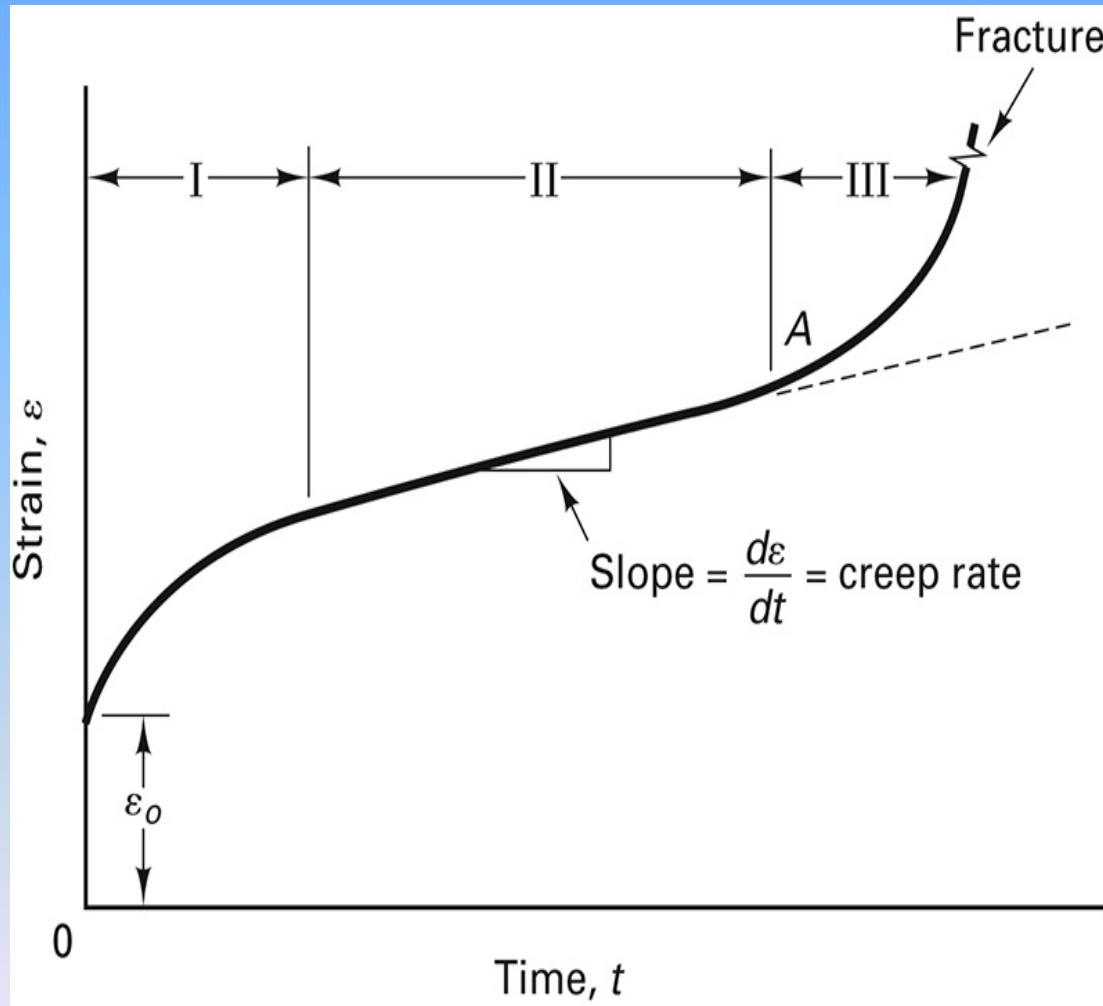

3.5 Machinability, Formability, and Weldability

- Machinability, formability, and weldability are the ways in which a material responds to a specific process
- Both the process and the machine dictate how the material will respond to manufacturing processes
- Each characteristic must be evaluated individually (i.e. there is no necessary relationship between machinability, formability, and weldability)

3.5 Machinability, Formability and Weldability

- Machinability: depends not only on worked material but on applied machining process (range of meanings).
- Formability (malleability, workability): materials suitability for plastic deformation (depends on process conditions).
- Weldability: depends on particular welding (joining) technique.

3.5 Machinability

- The ease with which a metal can be machined to an acceptable surface finish.
- Require little power to cut, can be cut quickly, easily obtain a good finish, and do not wear the tooling much;
- Such materials are said to be free machining.

3.5 Machinability

- Machinability can be based on the measure of how long a tool lasts.
- Higher specific energies equal lower machinability
- The surface finish is sometimes used to measure the machinability of a material. Soft, ductile materials tend to form a built up edge

3.6 Fatigue Failure

- Fatigue resistance is sensitive to sharp corners, surface cracks, gouges, etc.
- Fatigue life can be affected by changes in the environment (corrosion)
- Residual stresses can negatively impact fatigue life
- Crack growth continues with each successive application of the load until failure

3.6 Fracture Toughness

- Fracture toughness is a quantitative way of expressing a material's resistance to brittle fracture when a crack is present.
- If a material has a large value of fracture toughness it will probably undergo ductile fracture.
- Brittle fracture is very characteristic of materials with a low fracture toughness value.

3.6 Fracture Toughness

- All materials contains flaws or defects
- Material defects:
 - Pores
 - Cracks
 - Inclusions
- Manufacturing or Design defects
 - Abrupt section changes
 - Excessively small fillets
 - Small holes

3.6 Fracture Toughness/ Fracture Mechanics

- Materials contain flaws/defects of some size.
- By fracture dynamics cracks can be **dormant** (do not change) or **dynamic** (crack growth rate).
- Crack growth rate: change in size per loading cycle.

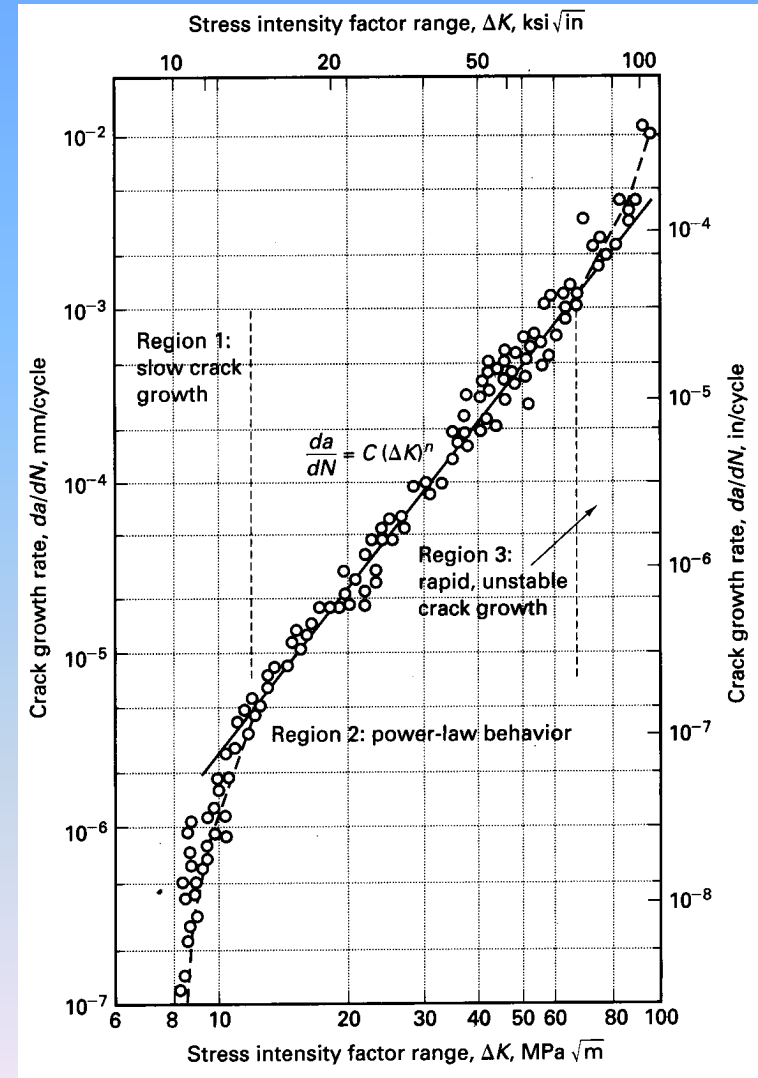

3.6 Fracture Mechanics

- Identify the conditions under which defects will grow
 - Size of the largest or most critical flaw
 - Applied stress
 - Fracture toughness
- Dormant defects are those whose size remains unchanged through the lifetime of the part
- Dynamic defects change through the life of the part

3.7 Physical Properties

- **Physical properties** are very important in material selection: density (weight), melting point, optical properties (color, transparency, opaqueness, thermal properties (specific heat, coefficient of thermal expansion, thermal conductivity, electrical conductivity and magnetic properties));

3.8 Testing Standards and Concerns

- American Society of Testing and Materials (ASTM) has standardized the testing methodologies for determining physical and mechanical properties
- Important that the tests are standardized and reproducible
- ASTM maintains and updates testing standards

Summary

- Material selection is extremely important to a successful product
 - Desired material properties must be determined
- Stress strain curve is a valuable engineering tool that demonstrates a material's behavior as loads are applied
- Variety of testing methodologies to determine material properties
 - Method in which they are tested is important to understand

Summary

- Most important properties determined material integrity.
- Techniques for properties determination are given.